

stadiumpro

HOLLYWOOD

USB
MICROPHONE

USER MANUAL
HOLLYUSB

POLAR PATTERN SELECTABLE



CARDIOID

PODCASTS
VOICEOVERS
VOCALS
INSTRUMENTS



STEREO

VOCALS
ENSEMBLE CHOIR
INSTRUMENTS



BIDIRECTIONAL

INTERVIEWS
INSTRUMENTS
VOCAL DUETS



OMNIDIRECTIONAL

CONFERENCE CALLS
FIELD RECORDINGS
EVENTS/ORCHESTRAS

stadiumpro

Features

- Pro audio broadcasting desktop microphone
- USB powered 'Plug-and-Play' operation
- Polar pattern selectable
- Connects to your computer for hassle-free sound control
- Used for podcasts, gaming, streaming, recording, audio editing
- Lab tested for stage & studio-quality performance
- Crisp vocal pickup, high-precision audio clarity
- Convenient mic mute button
- Selectable 5-color ambient emotion light effect (with off option/ECO mode)
- 3.5mm headphone jack input
- Adjustable mic volume & headphone volume control
- Freestanding mic placement on any desktop, counter, table
- Detachable USB-type C cable
- Detachable heavy metal spider mic stand (angle adjustable)
- High sensitivity, low noise and wide dynamic range
- Windows and Mac compatible, no drivers needed

Technical Specifications

- Pickup/Polar Pattern: Selectable Cardioid/Bidirectional/Stereo/Omnidirectional
- Microphone Type: Back electret condenser
- Connection Interface: USB 2.0 powered
- Sensitivity: -36dB +/- 2dB (0dB=1V/Pa at 1KHz)
- Max SPL: 130dB
- Frequency Response: 30-18.000Hz
- Output Impedance: 32 Ohm
- Mic Gain: -12dB, 12dB Max
- Resolution (Recording): 16 Bit/48 KHz
- Resolution (Playback): 24 Bit/96 KHz
- Computer Operating System Support: Windows XP, Vista, 7, 8, 10, Mac OS X, Linux

NOTE: Refer to the website for latest manuals and updates.

Attaching the stand

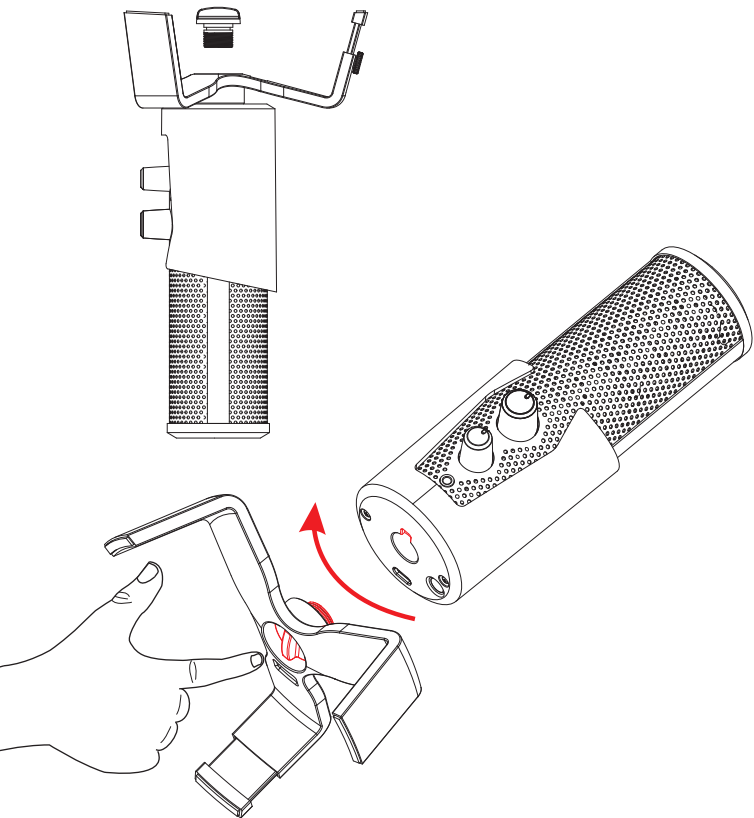

Stand angle adjustment

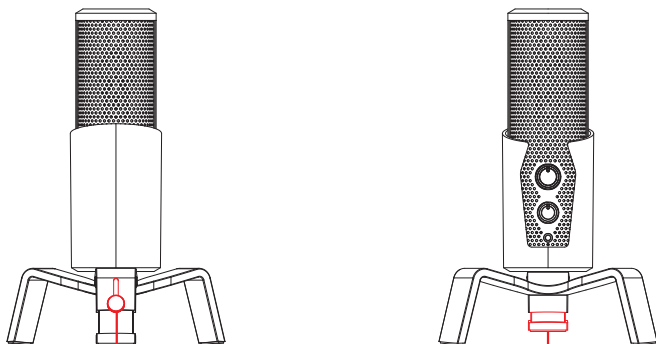

Twist knob anti-clockwise to loosen. Adjust leg height and twist clockwise to lock position

Microphone functions

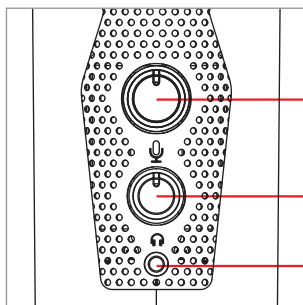

Dual function button

- A. Tune left to right to increase gain
- B. Press in to mute (LED glows RED)

Headphone volume controller

Headphone (3.5mm input)

Microphone functions

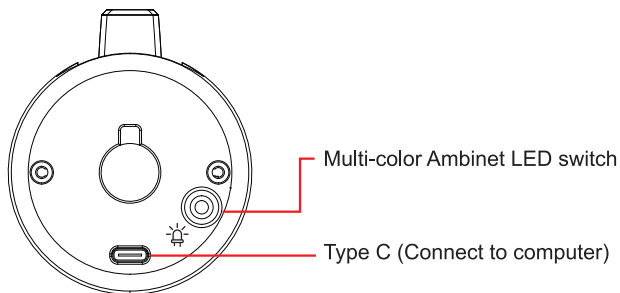

LED light controller

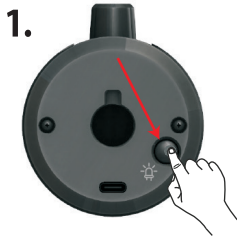

(Normal mode)
When short pressing this button the LED colours will change & LED's stays illuminated

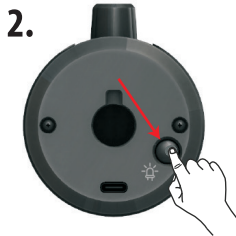

(Eco mode)
When long pressing this button (3 seconds) the LED's will switch off only MODE display wording will stay on

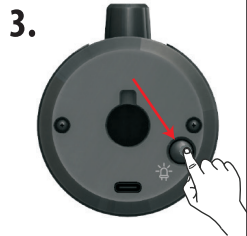

Long pressing this button again (3 seconds) the LED will switch back to **(Normal mode)**

Selecting polar pattern

Press the Mode button to select different polar pattern settings. LED lights will illuminate to show each pattern.

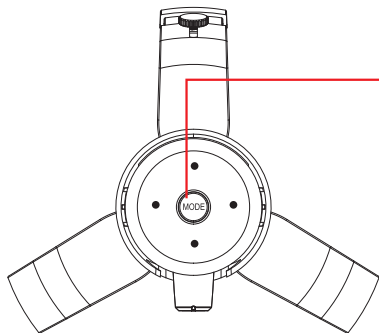

Polar pattern selection

- Cardioid(Front LED)
- Bidirectional
- Stereo
- Omnidirectional

- Cardioid mode is perfect for recording sounds directly in front of the microphone. This is the most used polar pattern. It is the most beneficial and best pattern for streaming and gaming.
- Bidirectional mode records sound from the front and rear of the microphone. It's typically used for interviews, but can be used by anyone sitting on opposite sides of the mic.
- Stereo mode uses both left and right channels to capture a realistic general sound image. It's great for recording musical instruments or acoustics.
- Omnidirectional mode picks up sound equally from all directions. This mode is best for multi-person broadcasts, so you can capture sound from around the room.

Additional Information

Selecting software

You have many choices in recording software. Audacity, available for free online at <http://sourceforge.net> is a widely used software program that provides basic recording software.

Setting your software levels

Correct adjustment of microphone level is important for optimum performance. Ideally, the microphone level should be as high as possible without overloading the input of your computer. If you hear distortion, or if your recording program shows levels that are consistently overloaded (at peak levels), turn the microphone volume (or level) down, either through your control panel (or system preferences) settings, or through your recording software. If your recording program shows insufficient level, you can increase the microphone gain either from the control panel (or system preferences) settings or through your recording program.

Positioning your microphone

It is important to position the microphone directly in line (on axis) with the person speaking/singing or instrument (or other sound source) to achieve the best frequency response of the microphone. This requires the user to speak into the microphone from the Stadium symbol side positioned towards the mouth. The distance from the mouth should be about 1 inch, or 10 - 40mm for optimal recording. For use in speaking/singing applications, the ideal placement for the microphone is directly in front of the person speaking/singing. The same placement is optimal when miking an instrument such as an acoustic guitar, drums or piano. Experiment with different mic placements to find the best sound for your particular setup based on the Polar pattern selected.

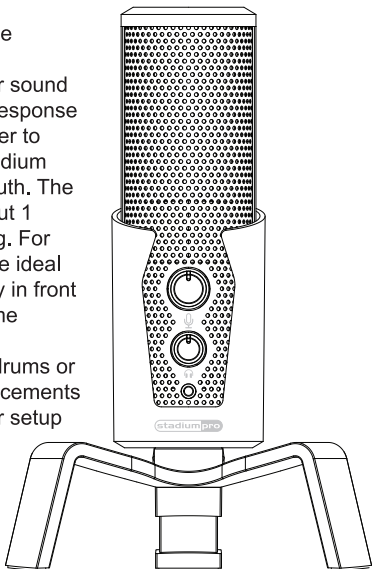

Frequency Response Diagram

Cardioid pattern

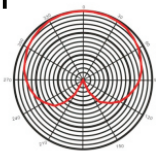
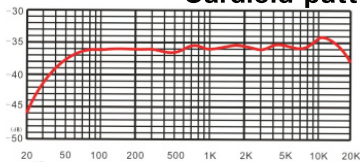

Bidirectional pattern

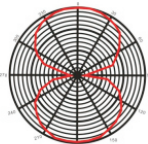
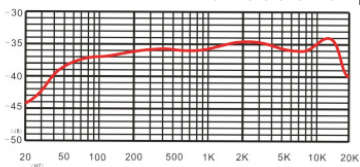

Stereo pattern

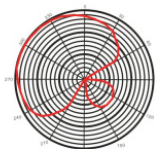
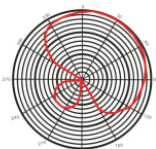
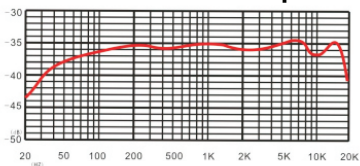

Omnidirectional pattern

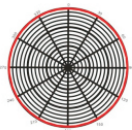
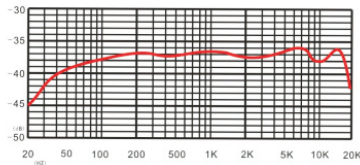

Preliminary setup with Mac OS X

1. Plug the free end of the provided USB cable into the USB port on your computer. Your computer will automatically recognize the USB device.
2. To select the **HOLLYWOOD** as your audio input, first open your System Preferences

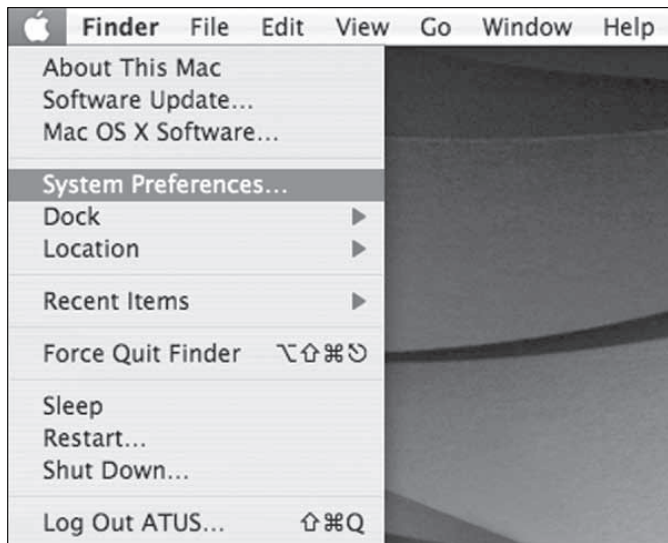

NOTE: Many recording software programs are available online. Audacity is widely used free software for recording and editing sounds. It is available online at <http://sourceforge.net>

Preliminary setup with Mac OS X (continued)

3. Next, click Sound to display the Sound Preference panel.

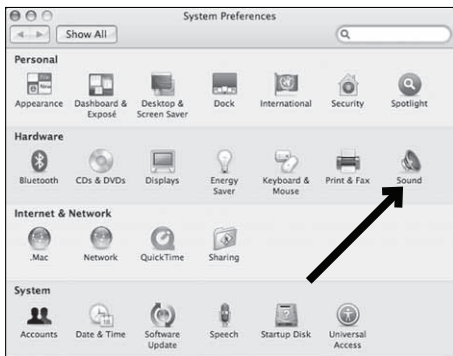

4. Click the input tab and select the **HOLLYUSB** as the device for sound input.

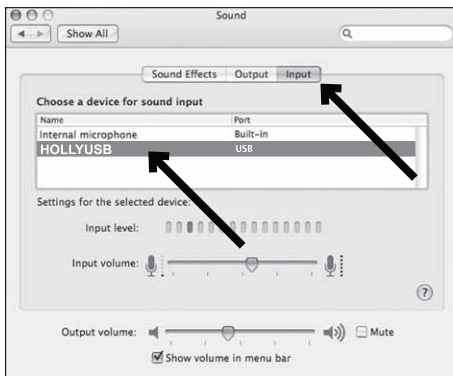

Your preferences are now set to use the HOLLYWOOD on your Mac with GarageBand or another recording program of your choice.

Preliminary setup with Windows XP

1. Plug the free end of the provided USB cable into the USB port on your computer. Your computer will automatically recognize the USB device.
2. To select the **HOLLYWOOD** as your default recording device, begin at your **START** menu.
3. Select **Control Panel**.

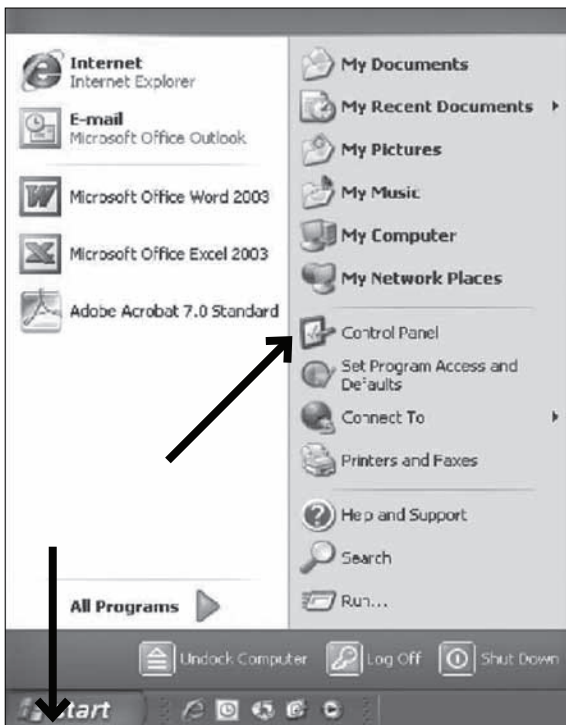

4. Select Sounds and Audio Devices.

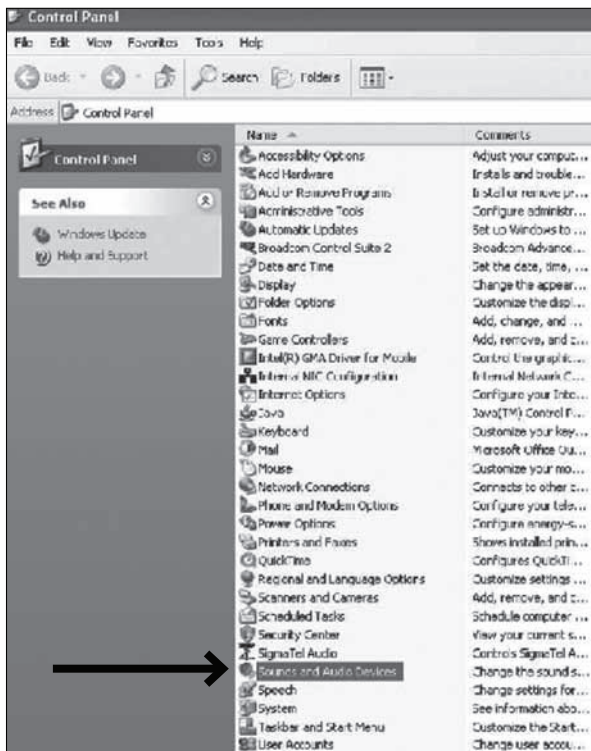

Preliminary setup with Windows XP (continued)

5. Select the Audio tab, and choose **HOLLYUSB** as the default device.
6. Adjust computer volume by clicking on the **Volume** button beneath Sound recording Default device.
7. Through the Wave In window, you can set the computer volume or mute the microphone.

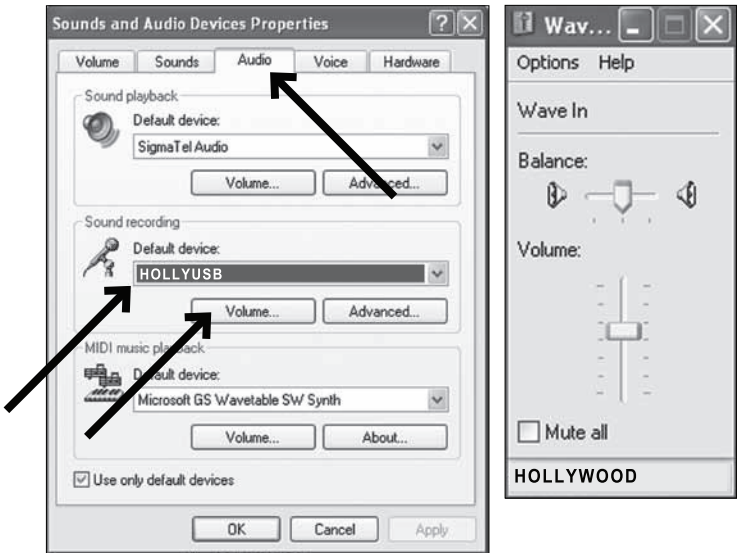

8. Your preferences are now set to use the HOLLYWOOD with Windows XP with the recording program of your choice.

Preliminary setup with Windows Vista

1. Plug the free end of the USB cable into the USB port on your computer. Your computer will automatically recognize the USB device.
2. To select the **HOLLYWOOD** as your default recording device, begin at your **START** menu. Select **Control Panel**
3. Select (double-click) **Sound**

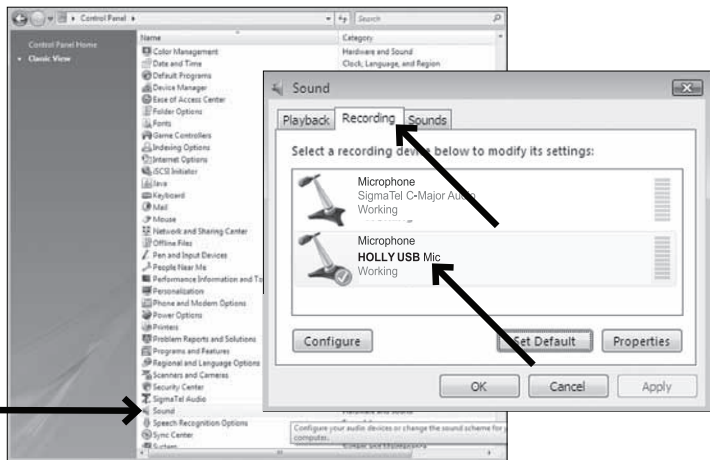

5. Select the Recording tab. Make sure that the **HOLLYUSB** microphone is set as the default recording device. (You should see a green check mark beside the USB microphone icon.)

Your preferences are now set to use the **HOLLYWOOD** with Windows Vista with the recording program of your choice.

Preliminary setup with Windows 7/10

1. Plug the free end of the USB cable into the USB port on your computer. Your computer will automatically recognize the USB device.

2. **START** menu > **Control Panel** > **Sound**

To select the **HOLLYUSB** as your default recording device, begin at your **START** menu. Select **Control Panel**

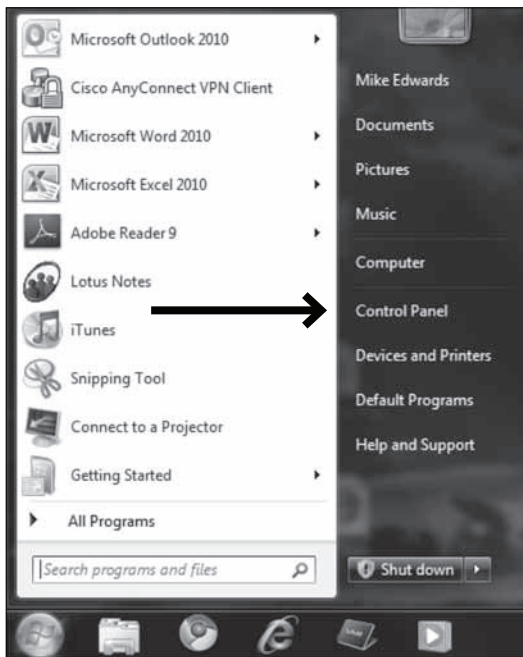

Preliminary setup with Windows 7/10 (continued)

4. Select Sound

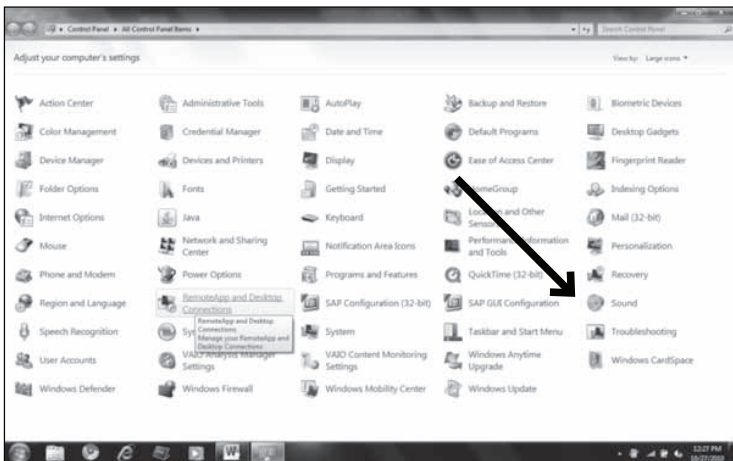

5. The following screen will pop up

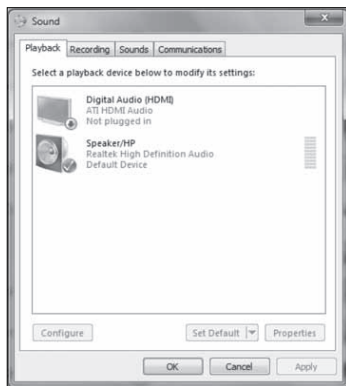

Preliminary setup with Windows 7/10 (continued)

6. Select the Recording tab, and choose **HOLLYUSB** as the default device.
7. Double click on the **HOLLYUSB** icon to open the Microphone Properties window. Select the levels tab to adjust microphone level (loudness). You may need to come back to this window to readjust the level after you begin recording.

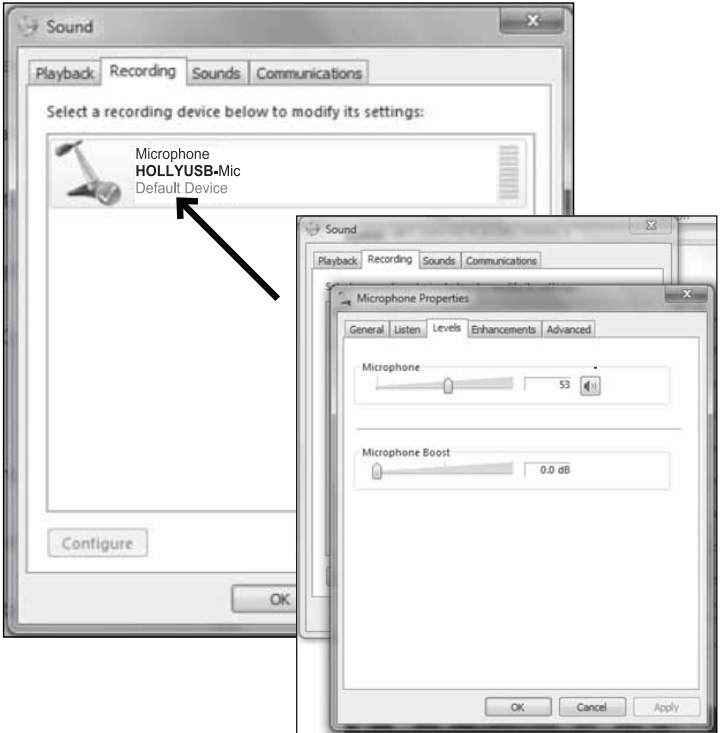

Your preferences are now set to use the HOLLYWOOD with Windows 7/10 with the recording program of your choice.

System Requirements †

Macintosh: Mac OS X; USB 1.0 or 2.0; 64 MB RAM (minimum);
Windows: XP/Vista/Windows 7; USB 1.0 or 2.0; 64 MB RAM (minimum)

† Specifications are subject to change without notice.

Inclusions

- 1 x USB Microphone
- 1 x Adjustable trifold stand
- 1 x USB cable length: 1.8M

Technical Assistance

If you need assistance setting up or using your Stadium product now or in the future, call Stadium support Australia

TEL: 03 – 8587 8898

FAX: 03 – 8587 8866

Mon-Fri 9am – 5pm AEST

This manual is considered correct at time of printing but is subject to change.
For latest manuals and updates refer to the website.

Copyright © 2017 by TDJ Australia

Scan QR code for
more products in
the STADIUM range



stadiumsound.com.au

