

Service
Service
Service



Service Manual



CONTENTS

Technical specification	1-2
Service measurement setup.....	1-3
Service aids	1-4
Instructions on CD playability	2-1.. 2-2
Block diagram.....	3-1
Wiring diagram	4-1
Main board	
Circuit diagram	5-1..5-5
Layout diagram.....	5-6..5-7
Panel board	
Circuit diagram	6-1
Layout diagram.....	6-2..6-3
Servo board	
Circuit diagram.....	7-1..7-2
Layout diagram.....	7-3
Exploded view diagram	8-1
Revision list	9-1

© Copyright 2010 Philips Consumer Electronics B.V. Eindhoven, The Netherlands
All rights reserved. No part of this publication may be reproduced, stored in a retrieval system or transmitted, in any form or by any means, electronic, mechanical, photocopying, or otherwise without the prior permission of Philips.

Published by LX 1017 Service Audio Subject to modification

3141 785 35010

Version 1.0

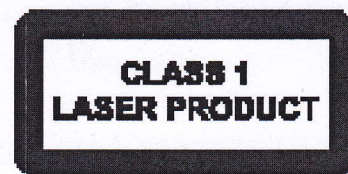

PHILIPS

TECHNICAL SPECIFICATION

Power supply	12 V DC (10.8 V - 15.8 V), negative ground
Fuse	15 A
Suitable speaker impedance	4 - 8 Ω
Maximum power output	50 W x 4 channels
Continuous power output	24 W x 4 channels (4 Ω 10% T.H.D.)
Pre-Amp output voltage	2.0 V (USB play mode; 1 kHz, 0 dB, 10 k Ω load)
Subwoofer output voltage	2.0 V (USB play mode: 61 Hz, 0 dB, 10 k Ω load)
Aux-in level	\geq 500 mV
Dimensions (W x H x D)	188 x 58 x 212 mm
Weight	1.67 kg
Operation temperature	-20 $^{\circ}$ c -- 70 $^{\circ}$ c

Radio

Frequency range - FM	87.5 - 108.0 MHz (Europe) 87.5 - 107.9 MHz (American)
Frequency range - AM(MW)	522 - 1620 KHz (Europe) 530 - 1710 HKz (American)
Usable sensitivity - FM	8 μ V
Usable sensitivity - AM(MW)	30 μ V

Bluetooth

Output power	0 dBm (Class 2)
Frequency band	2.4000 GHz - 2.4835 GHz ISM Band
Range	3 meters(free space)
Standard	Bluetooth 2.0 specification

MEASUREMENT SETUP

Tuner FM

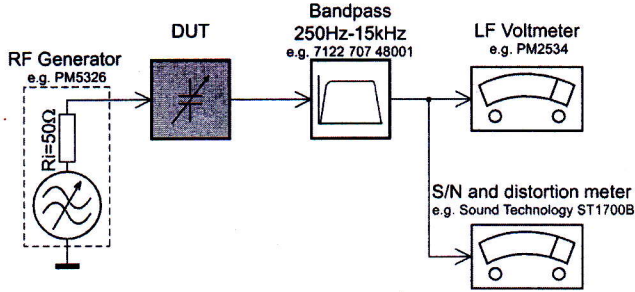

Use a bandpass filter to eliminate hum (50Hz, 100Hz) and disturbance from the pilotone (19kHz, 38kHz).

Tuner AM (MW,LW)

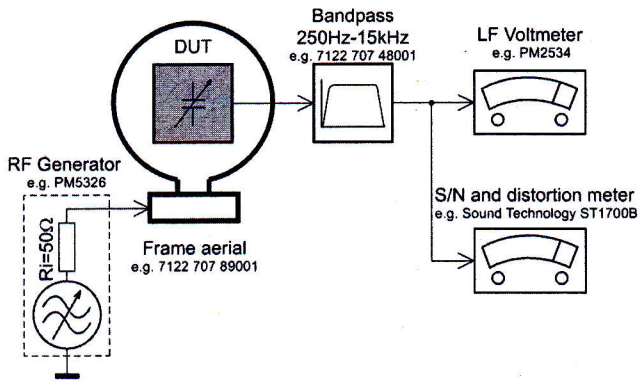

To avoid atmospheric interference all AM-measurements have to be carried out in a Faraday's cage. Use a bandpass filter (or at least a high pass filter with 250Hz) to eliminate hum (50Hz, 100Hz).

CD

Use Audio Signal Disc SBC429 4822 397 30184 (replaces test disc 3)

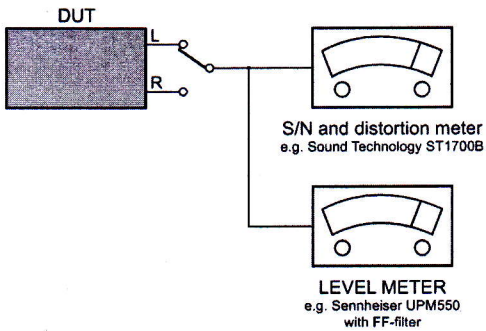

Recorder

Use Universal Test Cassette CrO2 SBC419 4822 397 30069 or Universal Test Cassette Fe SBC420 4822 397 30071

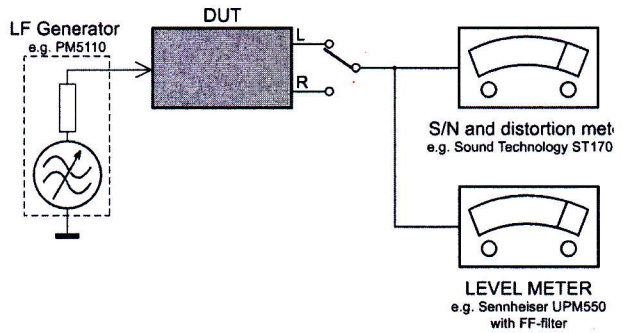

SERVICE AIDS

GB WARNING

All ICs and many other semi-conductors are susceptible to electrostatic discharges (ESD). Careless handling during repair can reduce life drastically.

When repairing, make sure that you are connected with the same potential as the mass of the set via a wrist wrap with resistance. Keep components and tools also at this potential.

ESD



GB

Safety regulations require that the set be restored to its original condition and that parts which are identical with those specified, be used

Safety components are marked by the symbol .

**CLASS 1
LASER PRODUCT**

INFORMATION ABOUT LEAD-FREE SOLDERING

Philips CE is producing lead-free sets from 1.1.2005 onwards.
IDENTIFICATION:

Regardless of special logo (not always indicated) one must treat all sets from 1 Jan 2005 onwards, according next rules:



- On our website www.atyourservice.ce.Philips.com you find more information to:
 - * BGA-de-/soldering (+ baking instructions)
 - * Heating-profiles of BGAs and other ICs used in Philips-sets
 - * Lead free

You will find this and more technical information within the "magazine", chapter "workshop news".

For additional questions please contact your local repair-helpdesk.

SERVICE INSTRUCTION

Safety regulations require that after a repair, the set must be returned in its original condition. Pay in particular attention to the following points:

- Route the wire trees correctly and fix them with the mounted cable clamps.
- Check the insulation of the AC Power lead for external damage.
- Check the strain relief of the AC Power cord for proper function.
- Check the electrical DC resistance between the AC Power Plug and the secondary side (only for sets which have a AC Power isolated power supply):
 1. Unplug the AC Power cord and connect a wire between the two pins of the AC Power plug.
 2. Set the AC Power switch to the "on" position (keep the AC Power cord unplugged!).
 3. Measure the resistance value between the pins of the AC Power plug and the metal shielding of the tuner or the aerial connection on the set. The reading should be larger than 4.5 Mohm (For U.S. it should be between 4.2 Mohm and 12 Mohm).
 4. Switch "off" the set, and remove the wire between the two pins of the AC Power plug.
- Check the cabinet for defects, to avoid touching of any inner parts by the customer.

INSTRUCTIONS ON CD PLAYABILITY

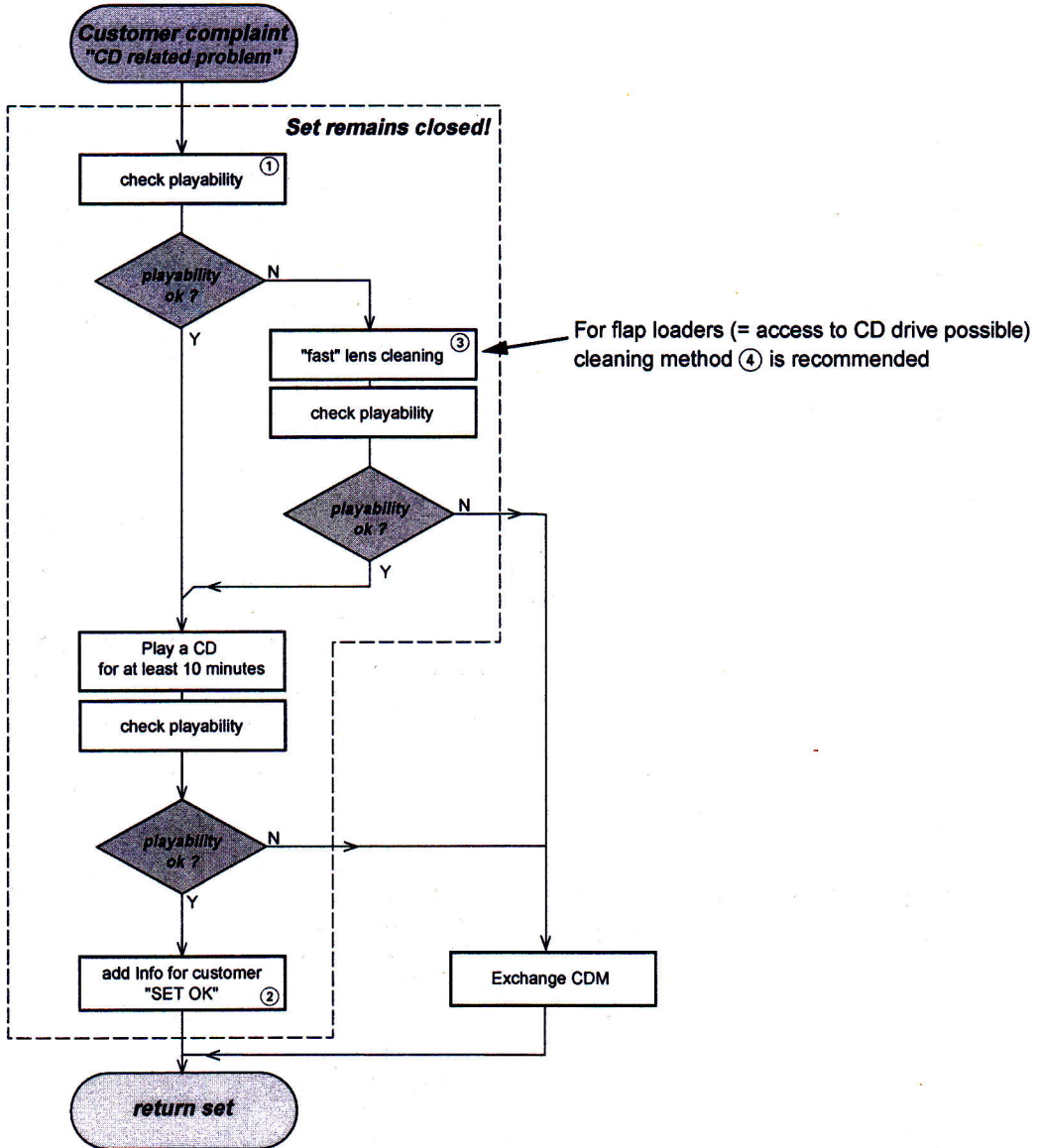

① - ④ For description - see following pages

INSTRUCTIONS ON CD PLAYABILITY

①

PLAYABILITY CHECK

For sets which are compatible with **CD-RW** discs
 use CD-RW Printed Audio Disc.....7104 099 96611
 TR 3 (Fingerprint)
 TR 8 (600 μ Black dot) **maximum at 01:00**

- playback of these two tracks without audible disturbance
 playing time for: Fingerprint ≥ 10 seconds
 Black dot from 00:50 to 01:10
- jump forward/backward (search) within a reasonable time

For all other sets
 use CD-DA SBC 444A.....4822 397 30245
 TR 14 (600 μ Black dot) **maximum at 01:15**
 TR 19 (Fingerprint)
 TR 10 (1000 μ wedge)

- playback of all these tracks without audible disturbance
 playing time for: 1000 μ wedge ≥ 10 seconds
 Fingerprint ≥ 10 seconds
 Black dot from 01:05 to 01:25
- jump forward/backward (search) within a reasonable time

②

CUSTOMER INFORMATION

It is proposed to add an addendum sheet to the set which informs the customer that the set has been checked carefully - but no fault was found.

The problem was obviously caused by a scratched, dirty or copy-protected CD. In case problems remain, the customer is requested to contact the workshop directly.

The lens cleaning (method ③) should be mentioned in the addendum sheet.

The final wording in national language as well as the printing is under responsibility of the Regional Service Organizations.

④

LIQUID LENS CLEANING

Before touching the lens it is advised to clean the surface of the lens by blowing clean air over it. This to avoid that little particles make scratches on the lens.

Because the material of the lens is synthetic and coated with a special anti-reflectivity layer, cleaning must be done with a non-aggressive cleaning fluid. It is advised to use "Cleaning Solvent"

The actuator is a very precise mechanical component and may not be damaged in order to guarantee its full function. Clean the lens gently (don't press too hard) with a soft and clean cotton bud moistened with the special lens cleaner.

The direction of cleaning must be in the way as indicated in the picture below.

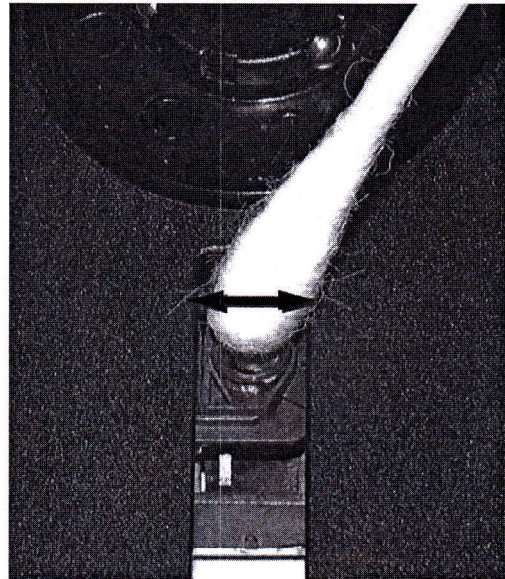

SET BLOCK DIAGRAM

3-1

3-1

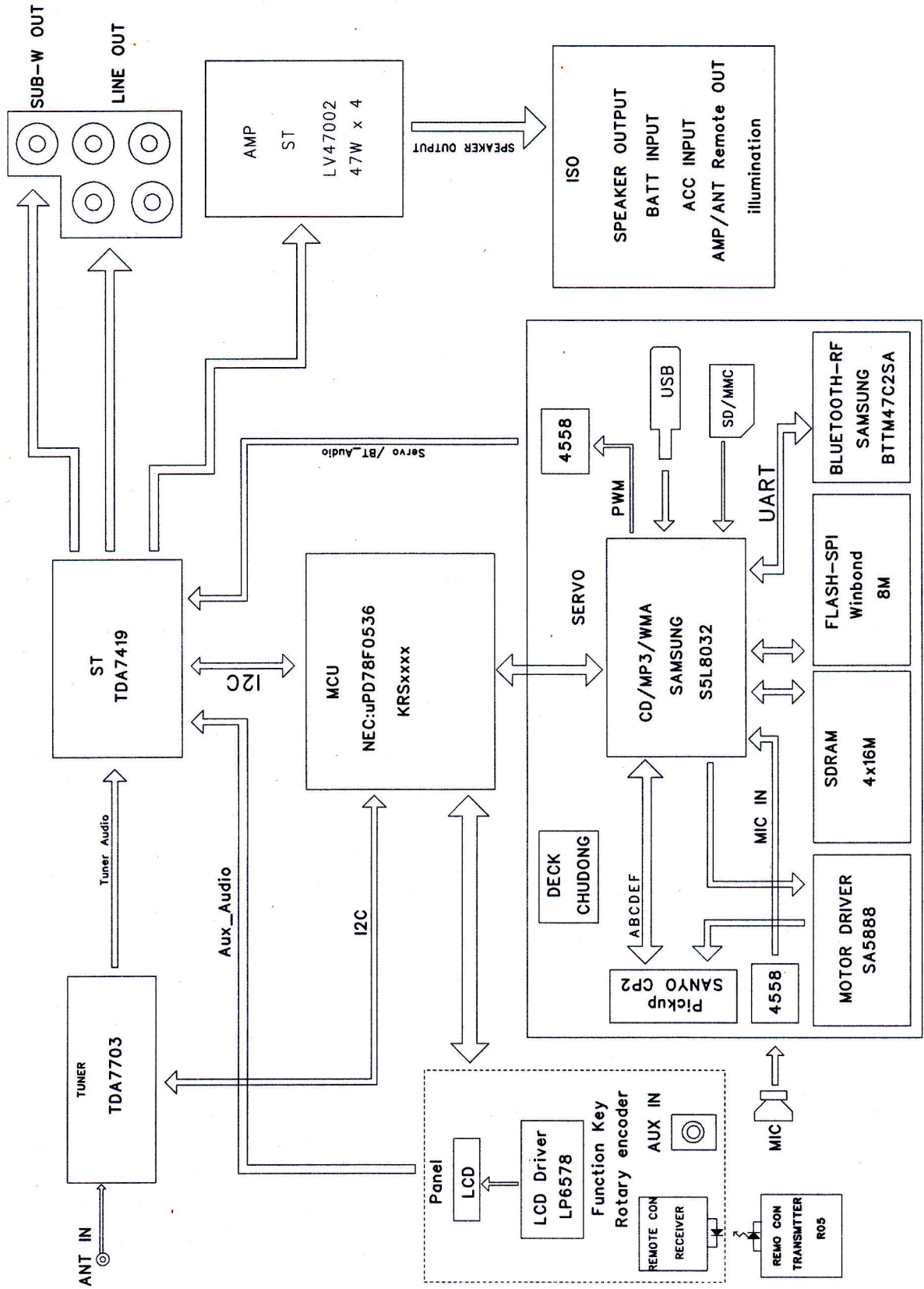

SET WIRING DIAGRAM

4-1

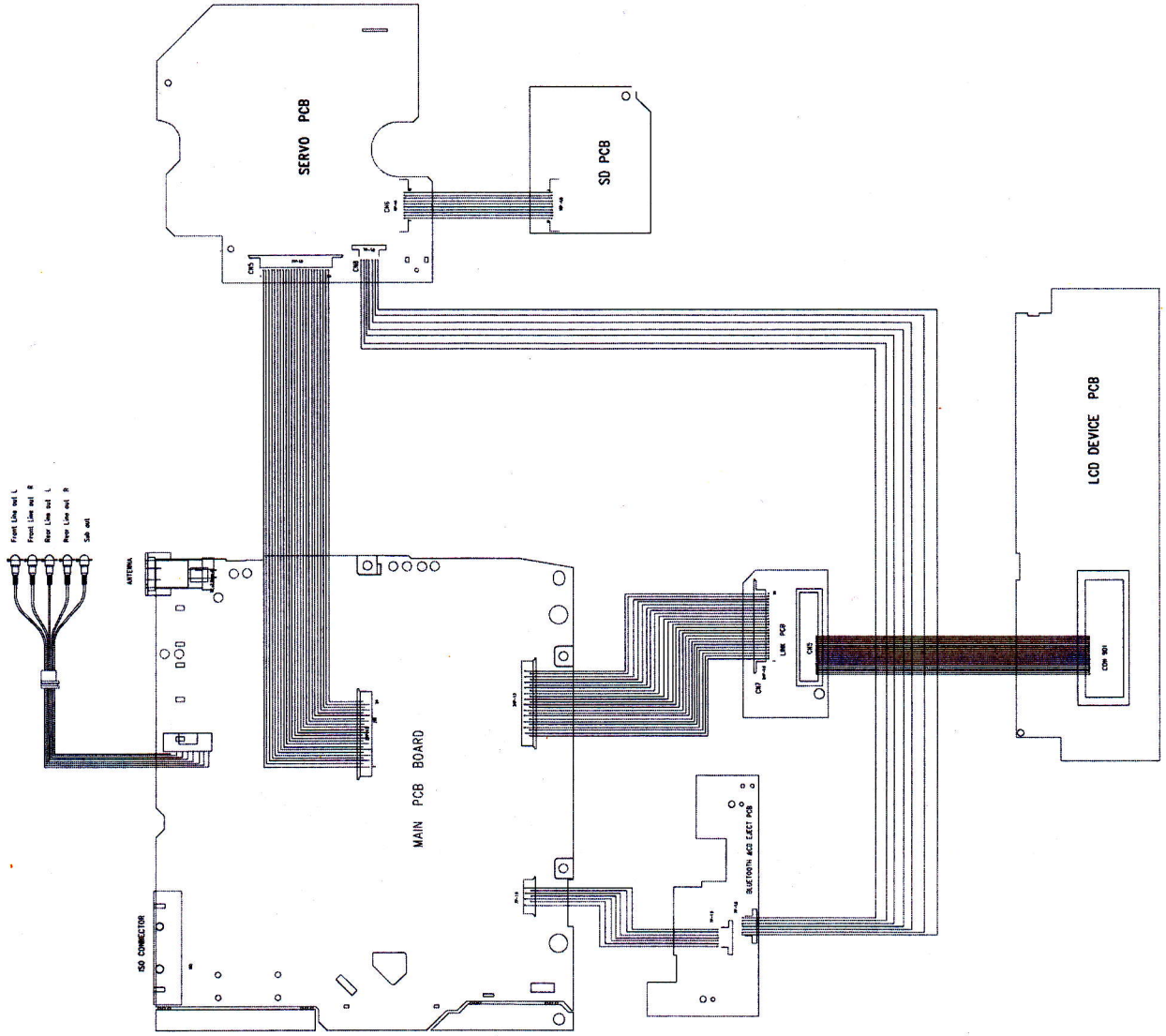

4-1

**CIRCUIT DIAGRAM - MAIN BOARD
PART 1**

5 - 1

5 - 1

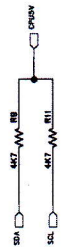
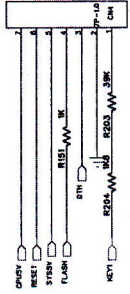
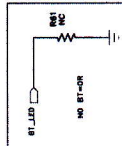
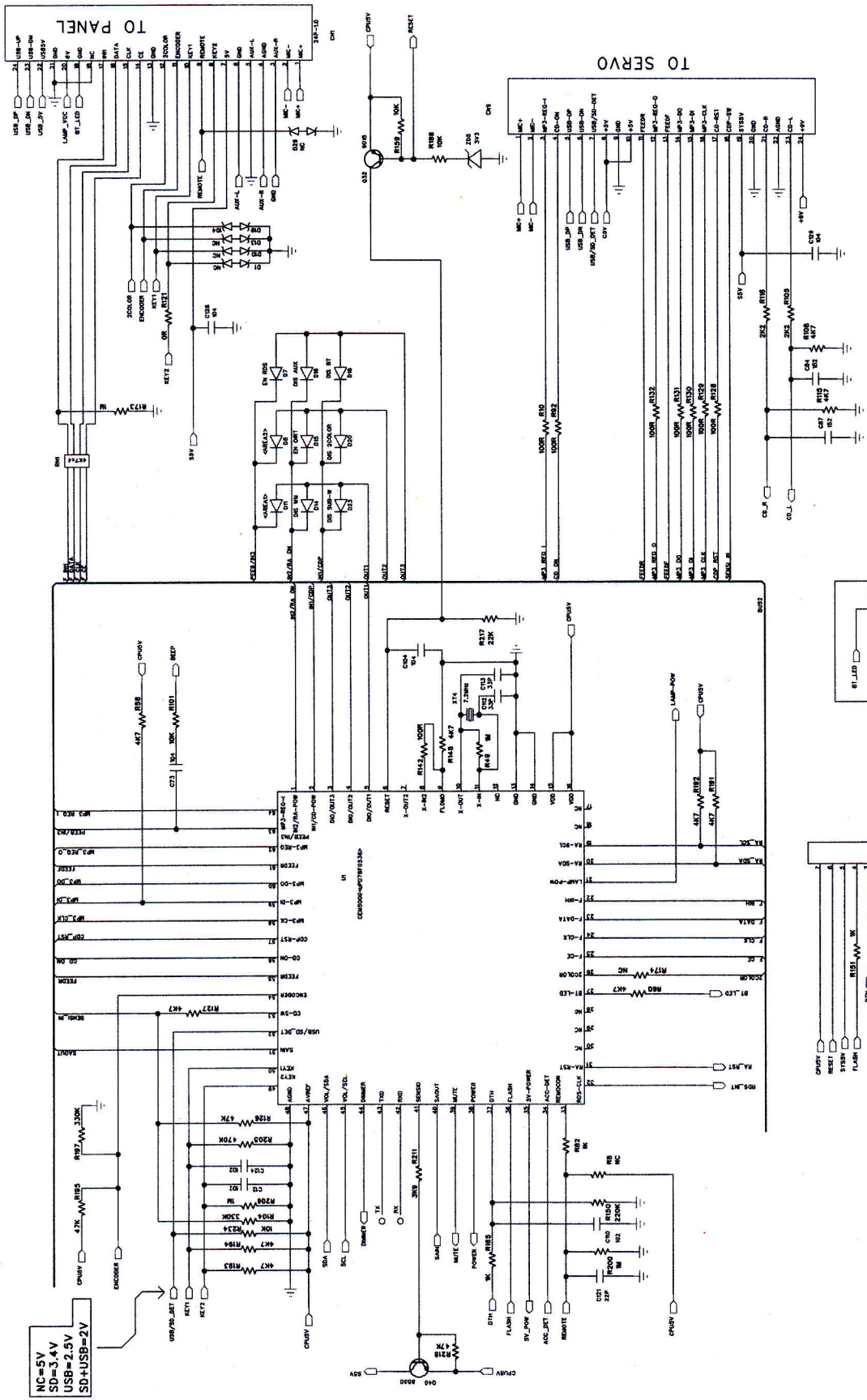

CIRCUIT DIAGRAM - MAIN BOARD PART 2

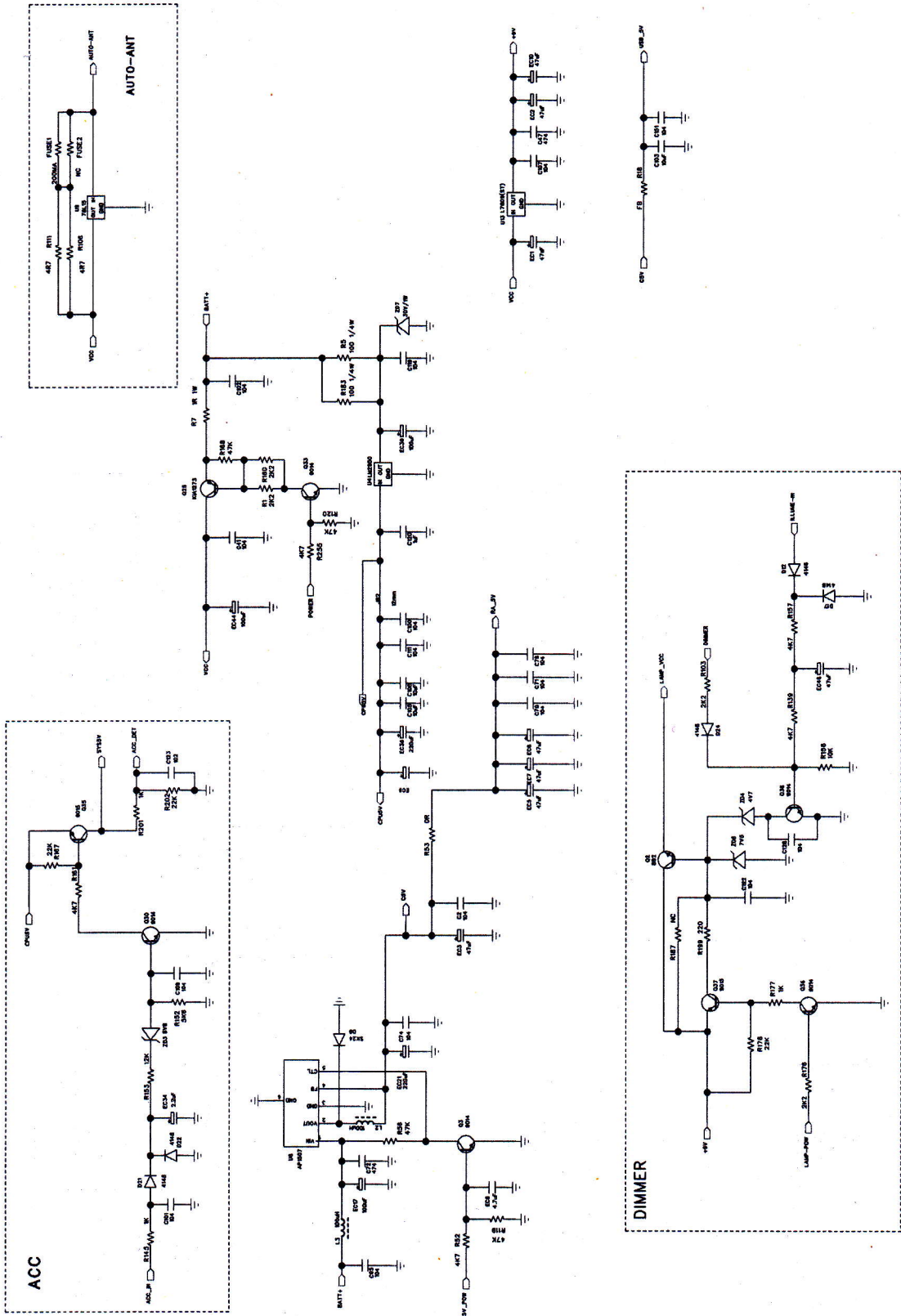

CIRCUIT DIAGRAM - MAIN BOARD
PART 4

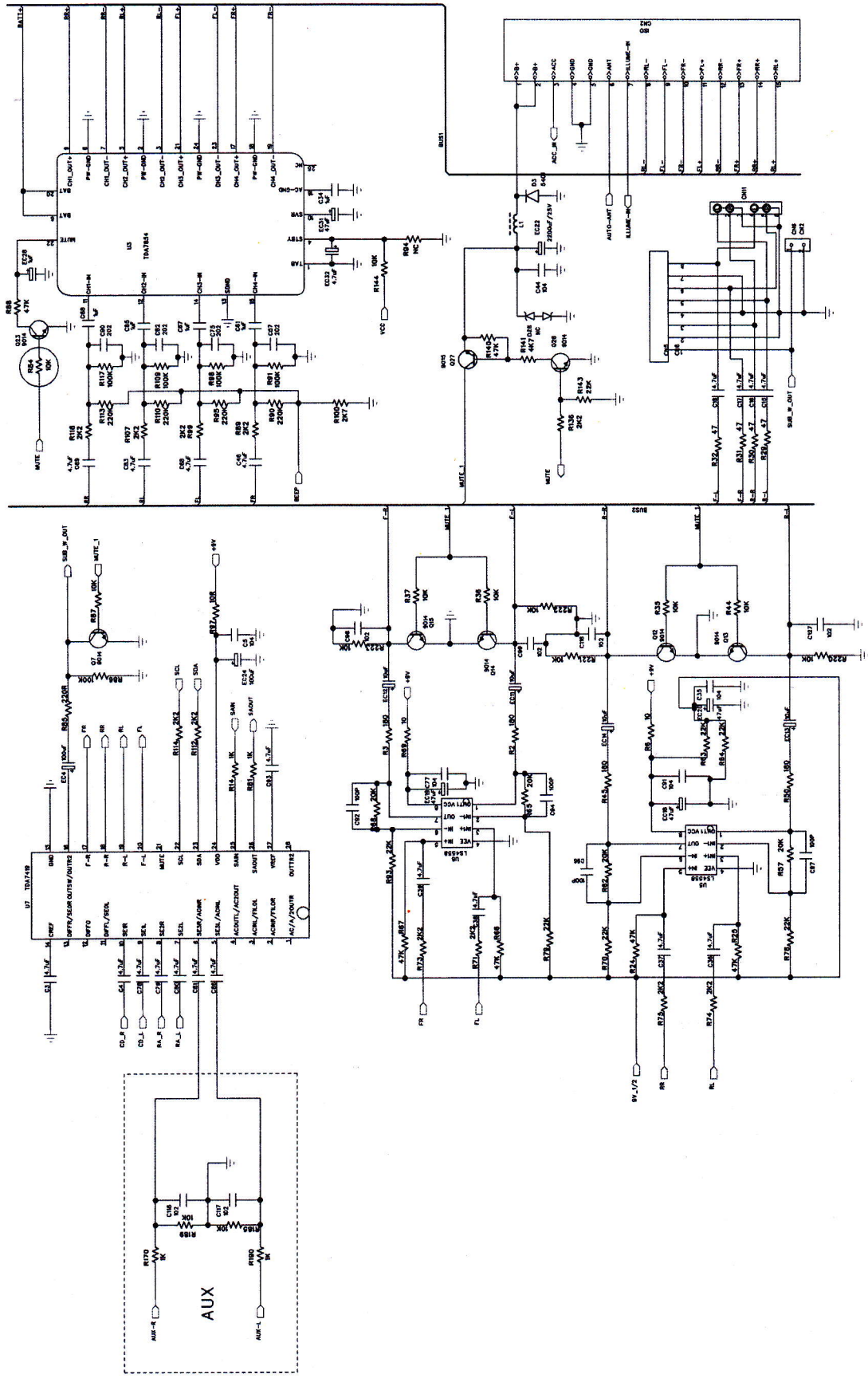

LAYOUT DIAGRAM - MAIN BOARD
TOP SIDE VIEW

5-6

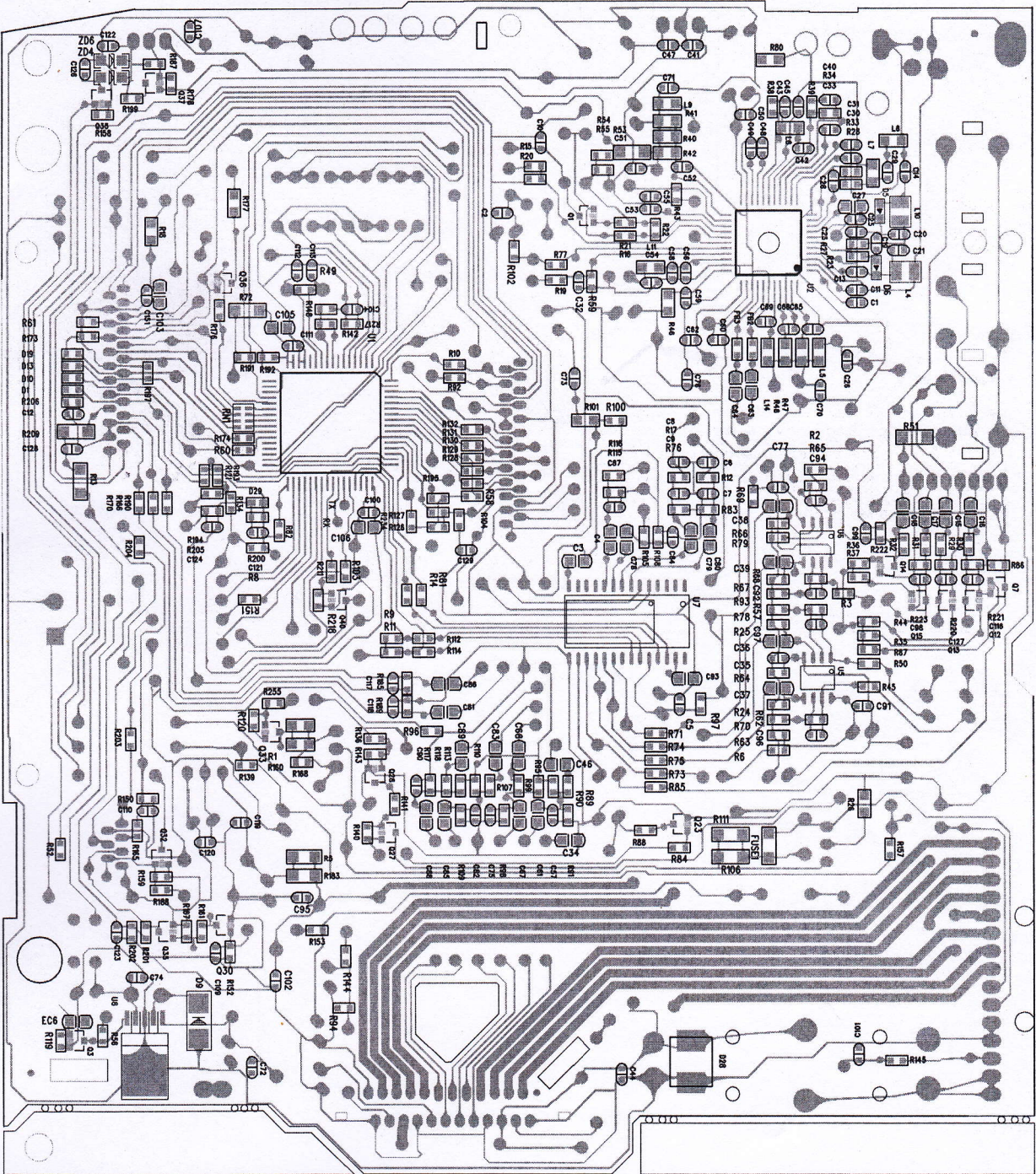

5-6

CIRCUIT DIAGRAM - PANEL BOARD

6 - 1

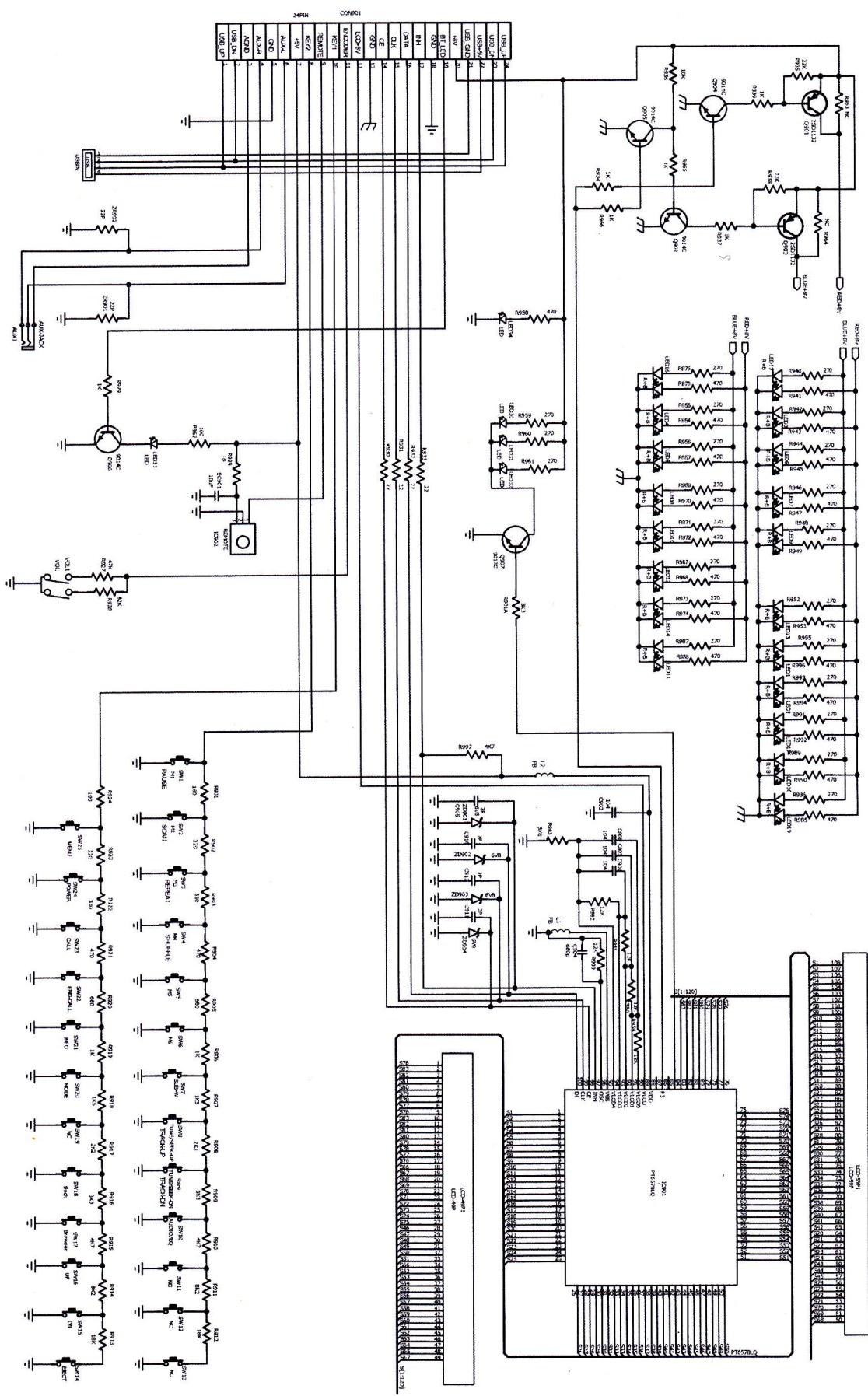

6 - 1

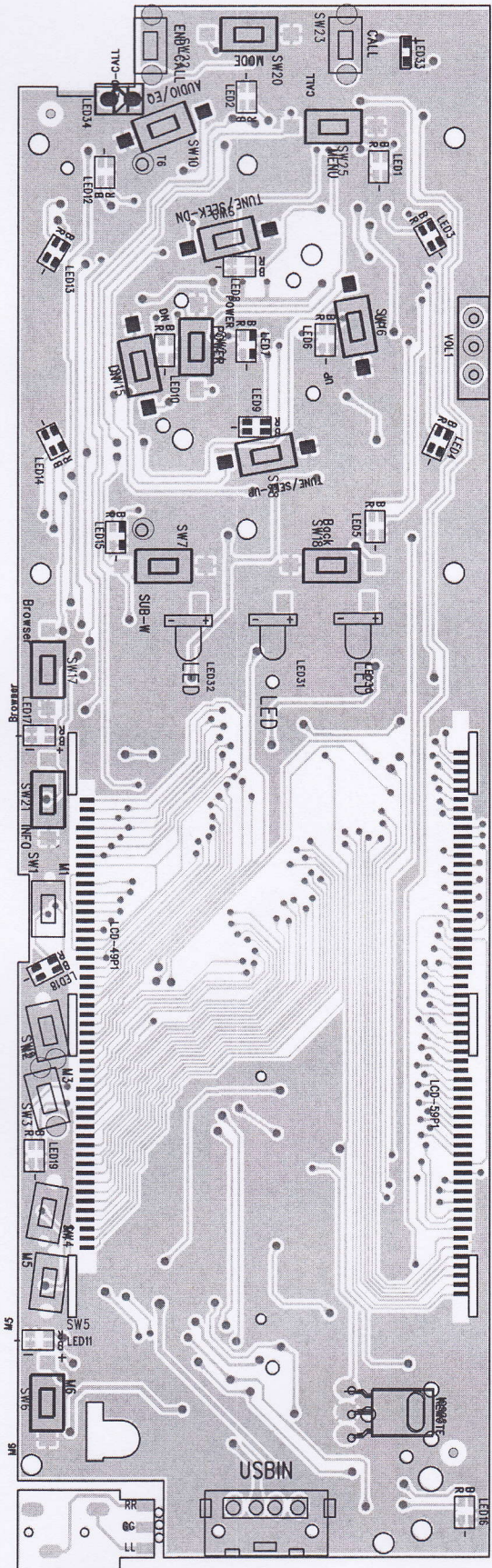
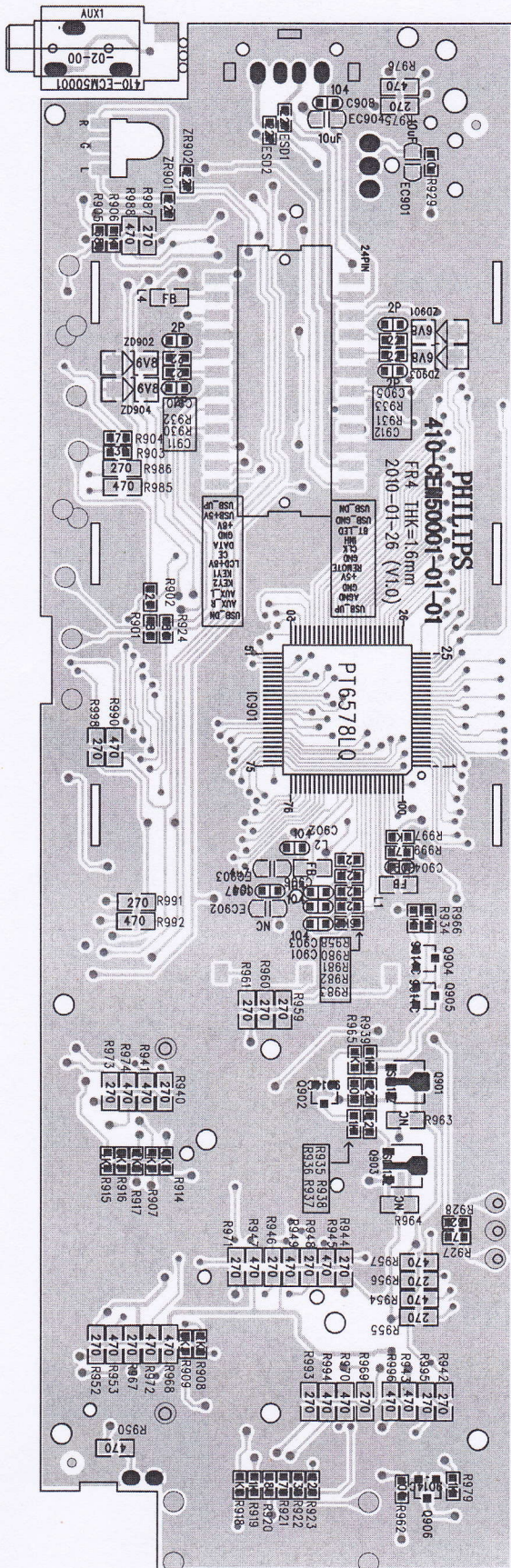

CIRCUIT DIAGRAM - SERVO BOARD
PART 1

7 - 1

7 - 1

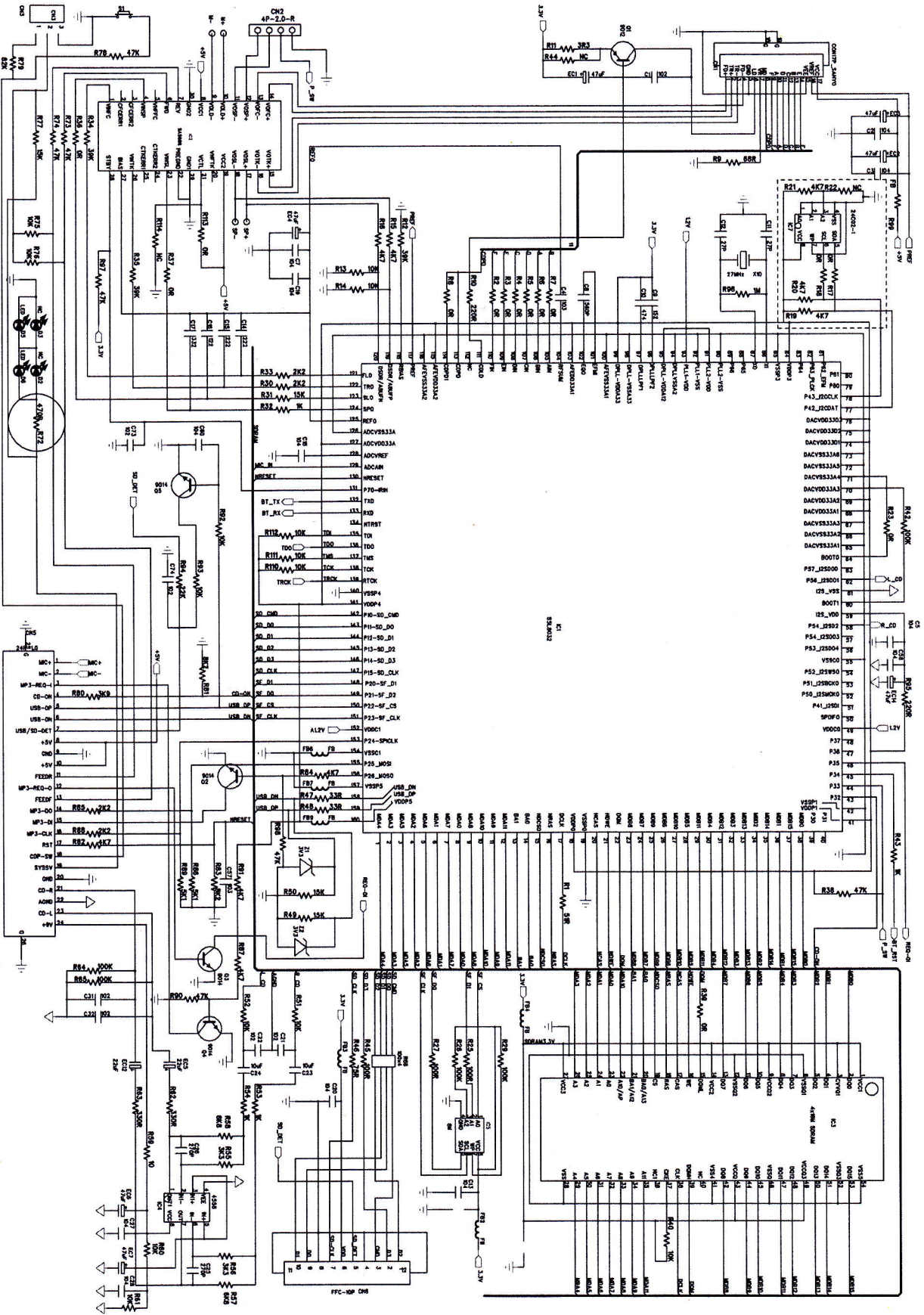

LAYOUT DIAGRAM - SERVO BOARD
TOP SIDE VIEW

7-3

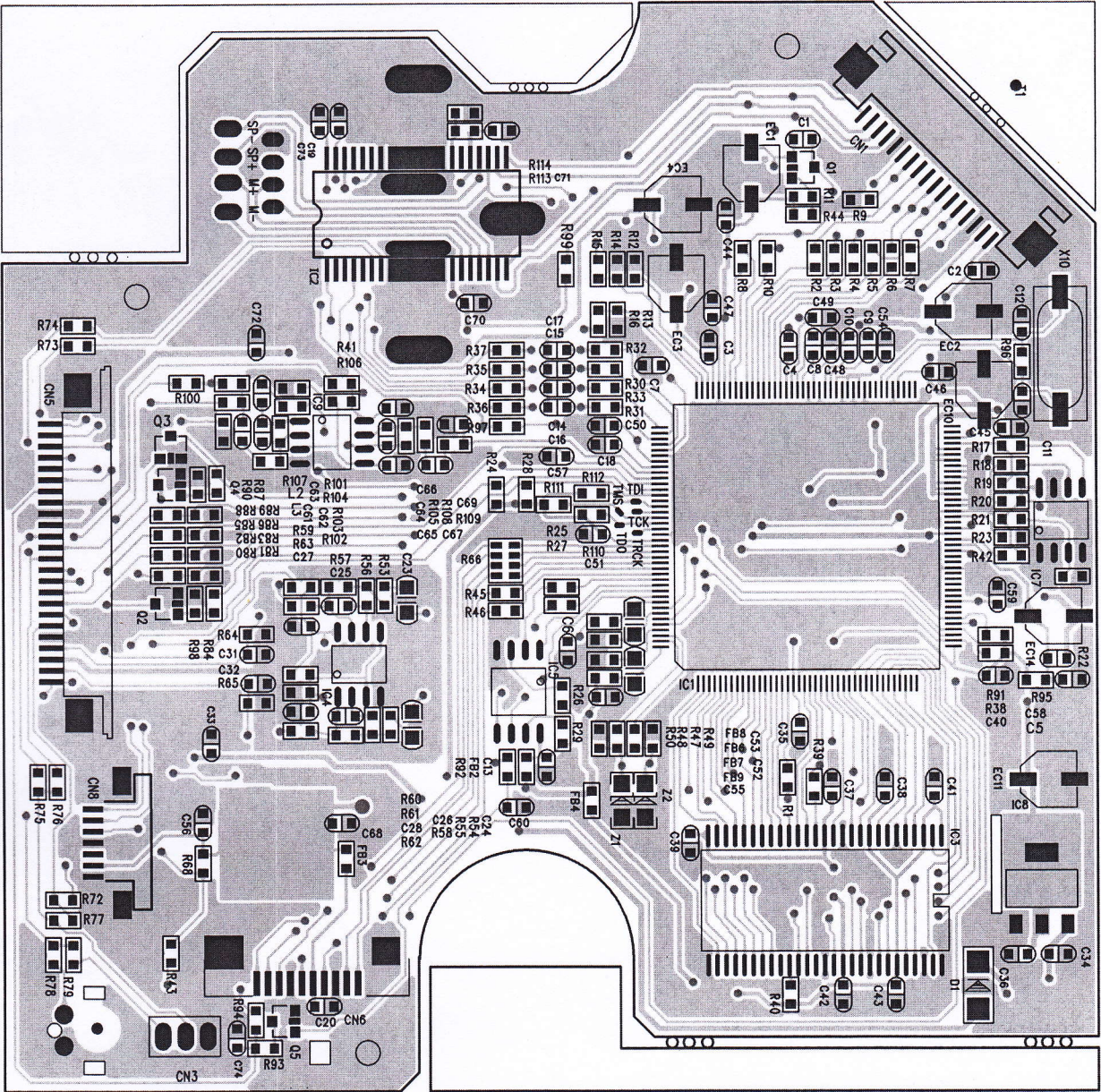

7-3

LAYOUT DIAGRAM - SERVO BOARD
BOTTOM SIDE VIEW

7-4

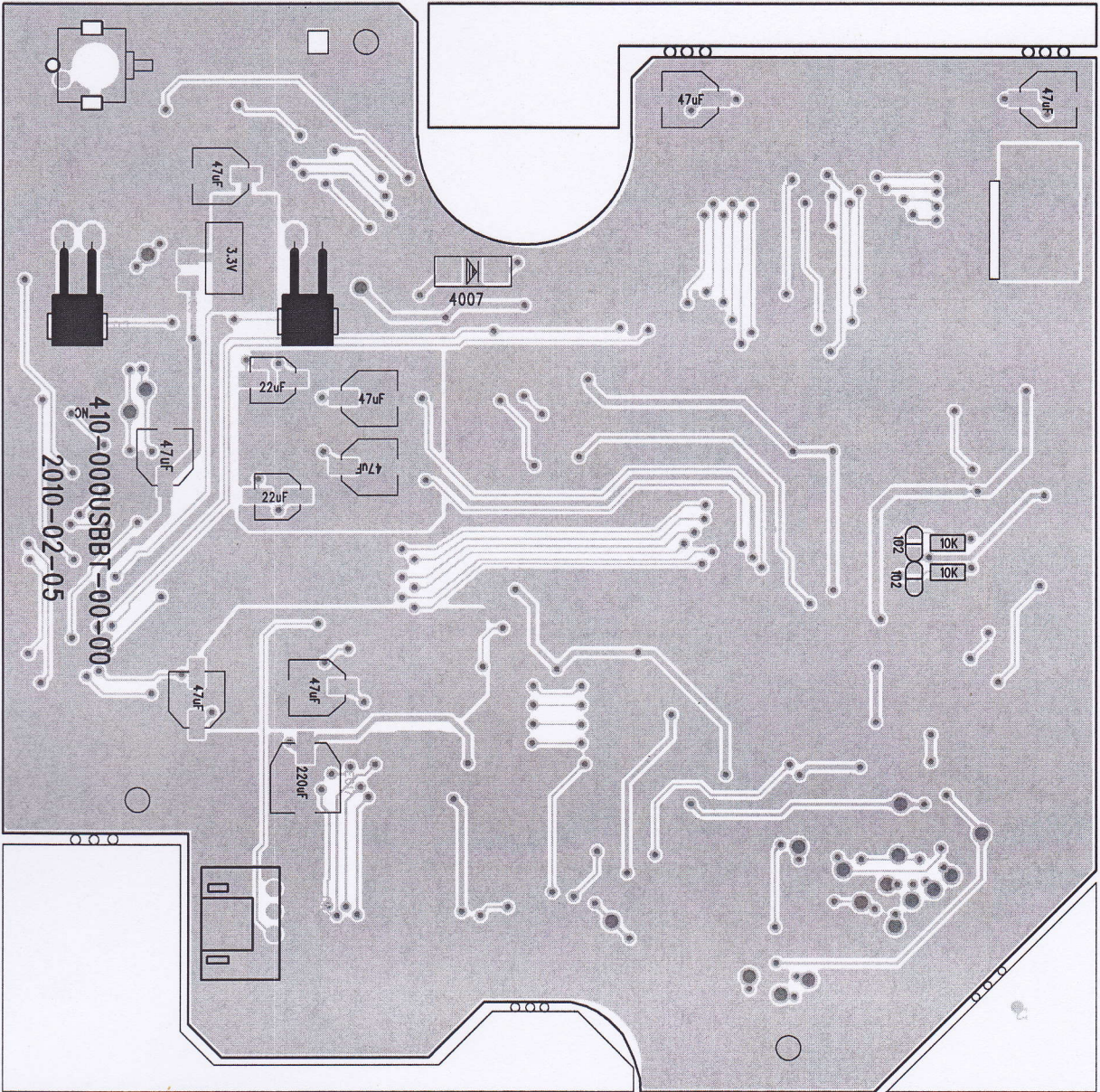

7-4

Revision list

Version 1.0 (3141 785 35010)
*Initial Release