

Register your product and get support at
www.philips.com/welcome

CEM200



EN User manual

PHILIPS

Contents

1	Important	4	7	Adjust system settings	18
	Safety	4		Turn demo mode on/off	18
	Notice	4		Select start volume	18
				Turn beep sound on/off	18
				Turn display scroll on/off	18
				Select shock-protect setting	19
				Reset	19
2	Your car audio system	6	8	Additional information	19
	Introduction	6		Detach the front panel	19
	What's in the box	6		Replace fuse	20
	Overview of the main unit	7		Remove the unit	20
	Overview of the remote control	8			
3	Get started	9	9	Product information	21
	Install the car audio	9			
	Install remote control battery	13			
	Turn on	14			
	Set clock	14			
4	Listen to radio	14	10	Troubleshooting	21
	Tune to a radio station	14			
	Store radio stations in memory	15			
	Tune to a preset station	15			
5	Play audio files	15	11	Glossary	22
	Play a disc	15			
	Control play	16			
	Search for an MP3/WMA track	16			
	View play information	16			
	Intro play	16			
	Shuffle play	16			
	Repeat play	16			
	Connect external sound source	16			
6	Adjust sound	17			
	Adjust volume	17			
	Mute	17			
	Turn Dynamic Bass Boost (DBB) on/off	17			
	Select preset equalizer	17			
	Other sound settings	17			

1 Important

Safety

- Read and understand all instructions before you use your apparatus. If damage is caused by failure to follow instructions, the warranty does not apply.
- This apparatus is designed for negative ground (earth) 12 V DC operation only.
- To ensure safe driving, adjust the volume to a safe and comfortable level.
- Improper fuses can cause damage or fire. When you need to change the fuse, consult a professional.
- Use only the supplied mounting hardware for a safe and secure installation.
- To avoid short circuit, do not expose the apparatus, remote control or remote control batteries to rain or water.
- Never insert objects into the ventilation slots or other openings on the apparatus.
- Clean the apparatus and frame with a soft, damp cloth. Never use substances such as alcohol, chemicals or household cleaners on the apparatus.
- Never place any objects other than discs into the apparatus.
- Never use solvents such as benzene, thinner, cleaners available commercially, or anti-static sprays intended for discs.
- Visible and invisible laser radiation when open. Avoid exposure to beam.
- Risk of damage to the apparatus screen! Never touch, push, rub or strike the screen with any object.



Caution

- Use of controls or adjustments or performance of procedures other than herein may result in hazardous radiation exposure or other unsafe operation.

Notice



Be responsible
Respect copyrights

The making of unauthorized copies of copy-protected material, including computer programs, files, broadcasts and sound recordings, may be an infringement of copyrights and constitute a criminal offence. This equipment should not be used for such purposes.

This apparatus includes these labels:



Class II equipment symbol



This symbol indicates that the apparatus has a double insulation system.

Recycling



Your product is designed and manufactured with high quality materials and components, which can be recycled and reused.

When you see the crossed-out wheel bin symbol attached to a product, it means the product is covered by the European Directive 2002/96/EC:



Never dispose of your product with other household waste. Please inform yourself about the local rules on the separate collection of electrical and electronic products. The correct disposal of your old product helps prevent potentially negative consequences on the environment and human health.

Your product contains batteries covered by the European Directive 2006/66/EC, which cannot be disposed of with normal household waste.

Please inform yourself about the local rules on separate collection of batteries. The correct disposal of batteries helps prevent potentially negative consequences on the environment and human health.



This product complies with the radio interference requirements of the European Community.

This product complies with the requirements of the following directives and guidelines: 2004/108/EC + 2006/95/EC.

Environmental information

All unnecessary packaging has been omitted. We have tried to make the packaging easy to separate into three materials: cardboard (box), polystyrene foam (buffer) and polyethylene (bags, protective foam sheet.)

Your system consists of materials which can be recycled and reused if disassembled by a specialized company. Please observe the local regulations regarding the disposal of packaging materials, exhausted batteries and old equipment.

Any changes or modifications made to this device that are not expressly approved by Philips Consumer Lifestyle may void the user's authority to operate the equipment.

2009 © Koninklijke Philips Electronics N.V. All rights reserved.

Specifications are subject to change without notice. Trademarks are the property of Koninklijke Philips Electronics N.V. or their respective owners. Philips reserves the right to change products at any time without being obliged to adjust earlier supplies accordingly.

2 Your car audio system

Congratulations on your purchase, and welcome to Philips! To fully benefit from the support that Philips offers, register your product at www.philips.com/welcome.

Introduction

With the in-car audio system, you can enjoy your drive while you listen to:

- FM or AM (MW) radio
- Audio from CD or MP3 disc
- Audio from external devices

What's in the box

Check and identify the contents of your package:

- ① In-car audio system
- ② Remote control
- ③ Rubber cushion
- ④ Screw (4 pieces)
- ⑤ Disassembly tool (2 pieces)
- ⑥ Front panel
- ⑦ Trim plate
- ⑧ Carrying case for front panel
- ⑨ User manual
- ⑩ Quick start guide
- ⑪ Standard connector

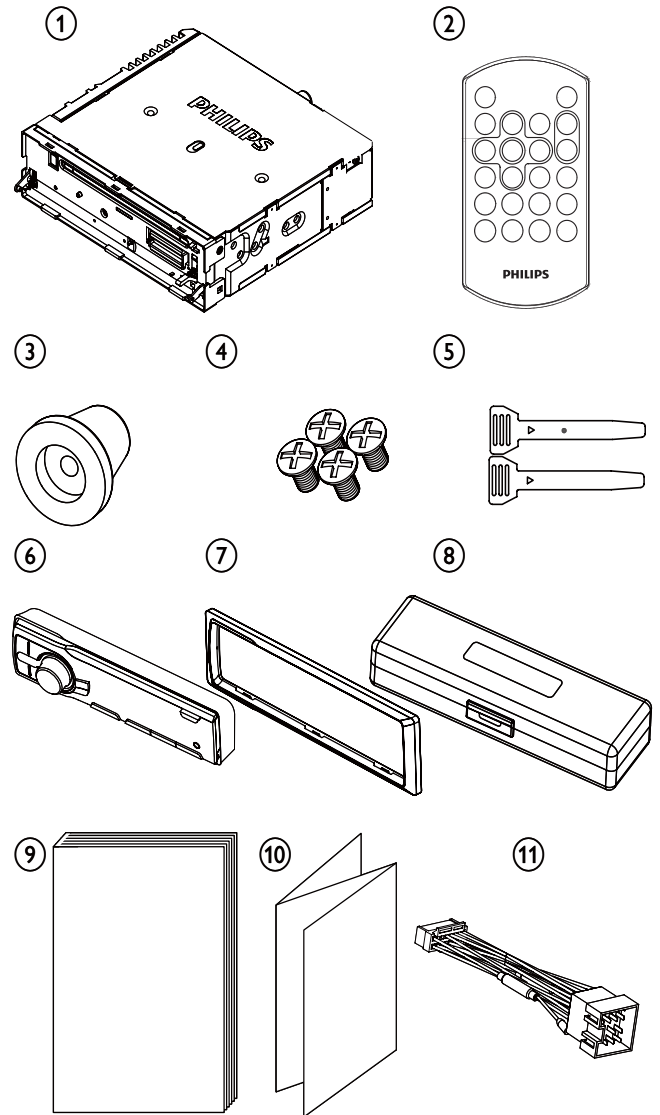

Overview of the main unit

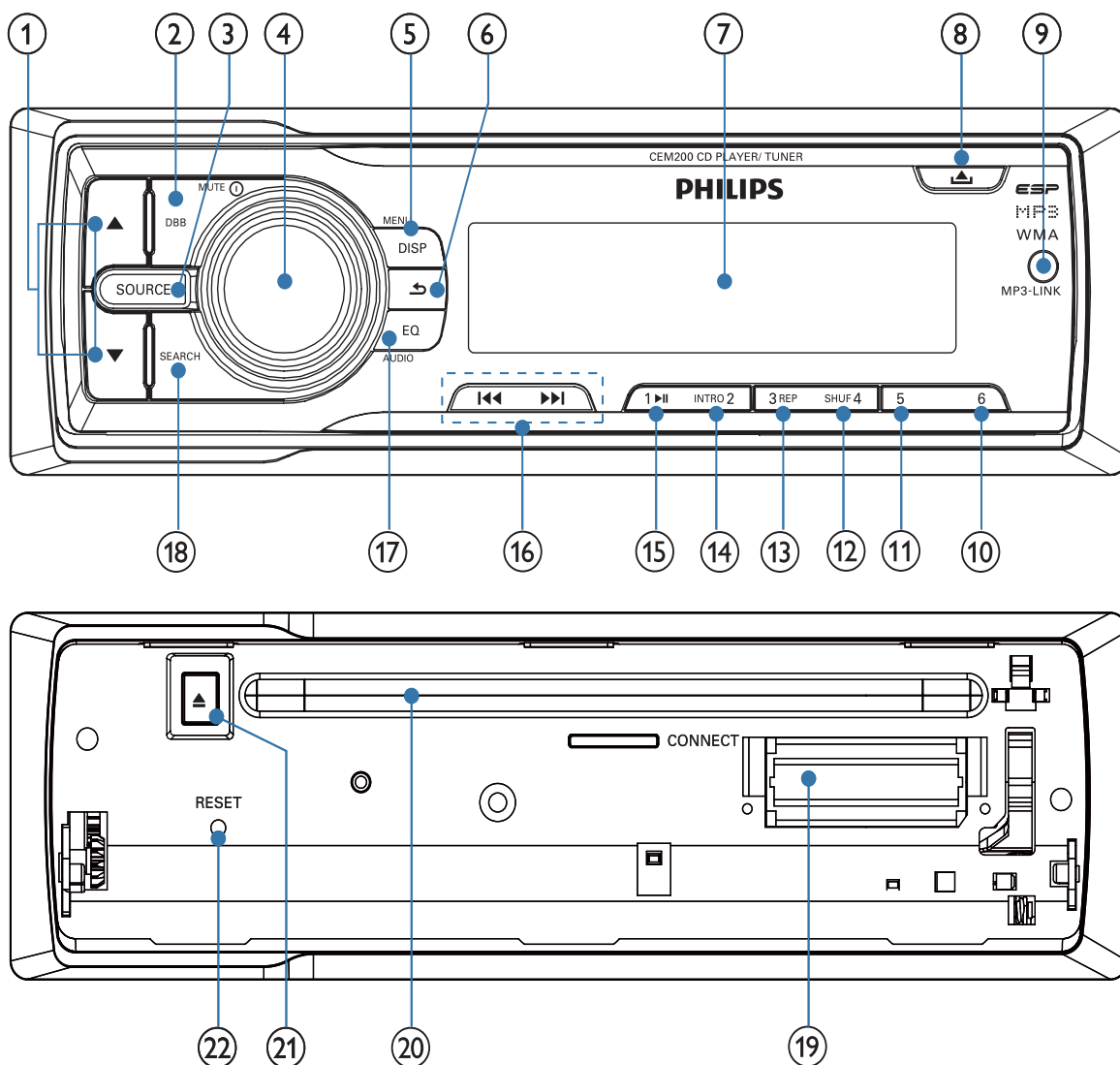

- ① ▲▼
- Select tuner band.
 - Select MP3/WMA folder.
 - Scroll up or down menu.
- ② **DBB**
- Turn on or off Dynamic Bass Boost (DBB) sound.
- ③ **SOURCE**
- Select audio source.
- ④ **Ⓜ/MUTE**
- Turn the unit on or off.
 - Adjust volume.
 - Confirm selection.
 - Enter characters for search.
 - Mute or restore volume.
- ⑤ **MENU / DISP**
- Display radio frequency, clock and radio program type (if available).
 - Display track, elapsed time, artist, album, title, folder, file and clock.
 - Access system menu.
- ⑥ **↶**
- Return to previous menu.
 - Stop search.
 - Disable screen blackout.
- ⑦ **Display panel**
- ⑧ **▲**
- Unlock the panel
- ⑨ **External device socket**

Overview of the remote control

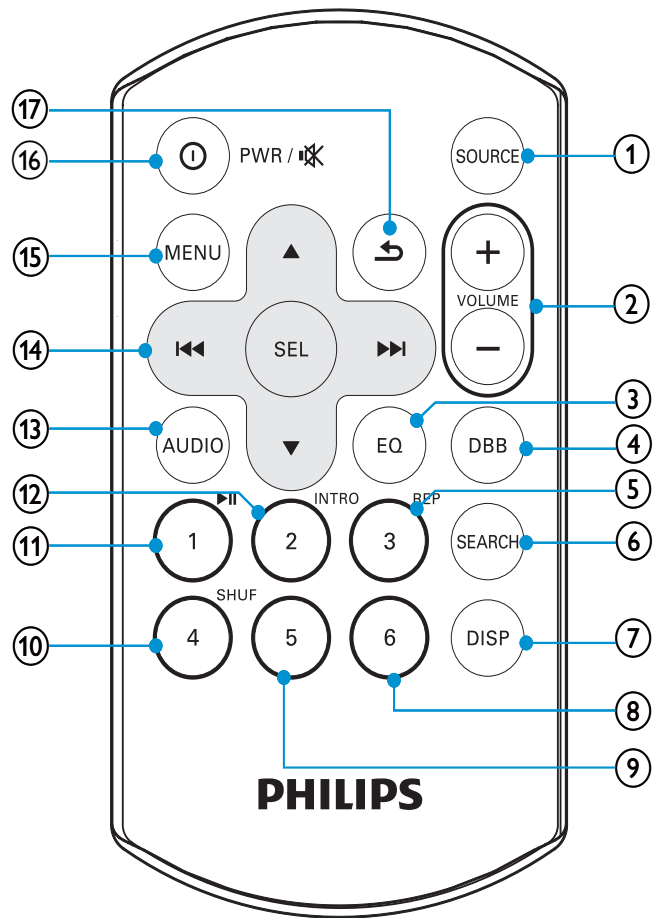

- ⑩ 6
 - Select preset station no. 6
- ⑪ 5
 - Select preset station no. 5
- ⑫ SHUF, 4
 - Activate or deactivate shuffle mode.
 - Select preset station no. 4
- ⑬ 3, REP
 - Set repeat play mode.
 - Select preset station no. 3
- ⑭ INTRO, 2
 - Turn intro play on or off.
 - Select preset station no. 2
- ⑮ 1, ►||
 - Start play
 - Pause or resume play.
 - Select preset station no. 1
- ⑯ ◀◀/▶▶
 - Tune to a radio station
 - Skip/search for a track.
- ⑰ EQ/Audio
 - Select equalizer (EQ) setting.
 - Access audio setting menu.
- ⑱ SEARCH
 - Store radio stations automatically.
 - Search a track or folder.
- ⑲ Panel power connection
- ⑳ Disc slot
- ㉑ ▲
 - Take disc out.
- ㉒ RESET
 - Restore default settings.

- ① SOURCE
 - Select audio source.
- ② VOLUME +/-
 - Adjust volume.
- ③ EQ
 - Select EQ setting.
- ④ DBB
 - Turn on or off Dynamic Bass Boost (DBB) sound.
- ⑤ 3, REP
 - Select repeat play mode.
 - Select preset station no. 3.
- ⑥ SEARCH
 - Store radio stations automatically.
 - Search a track or folder.

- ⑦ **DISP**
- Display radio frequency and clock.
 - Display track, elapsed time, artist, album, title, folder, file and clock.
- ⑧ **6**
- Select preset station no. 6.
- ⑨ **5**
- Select preset station no. 5.
- ⑩ **SHUF, 4**
- Activate or deactivate shuffle mode.
 - Select preset station no. 4.
- ⑪ **1, ►||**
- Start play.
 - Pause or resume play.
 - Select preset station no. 1.
- ⑫ **INTRO, 2**
- Turn intro play on or off.
 - Select preset station no. 2.
- ⑬ **AUDIO**
- Access audio setting menu.
- ⑭ **Navigation buttons**
- **◀◀/▶▶**
Tune for radio station
Skip/search for MP3/WMA track.
 - **▲/▼**
Select tuner band.
Select MP3/WMA folder.
 - **SEL**
Confirm selection.
- ⑮ **MENU**
- Access system menu.
- ⑯ **⓪PWR, 📶**
- Turn the unit on or off.
 - Mute or restore volume.
- ⑰ **↶**
- Return to previous menu.
 - Disable screen blackout.

3 Get started



Caution

- Use the controls only as stated in this user manual.

Always follow the instructions in this chapter in sequence.

If you contact Philips, you will be asked for the model and serial number of your apparatus. The model number and serial number are on the bottom of your apparatus. Write the numbers here:

Model No. _____

Serial No. _____

Install the car audio

These instructions are for a typical installation. However, if your car has different requirements, make the corresponding adjustment. If you have any questions regarding installation kits, consult your Philips car audio dealer.



Caution

- This unit is designed for negative ground (earth) 12 V DC operation only.
- Always install this unit in the car dashboard. Other locations can be dangerous as the rear of the unit heats up during use.
- To avoid short-circuit: before you connect, ensure that the ignition is off.
- Ensure that you connect the yellow and red power supply leads after all other leads are connected.
- Ensure that all loose leads are insulated with electrical tape.
- Ensure that the leads do not get caught under screws or parts that will move (e.g. seat rail).
- Ensure that all ground (earth) leads are run to a common ground (earth) point.
- Use only the supplied mounting hardware for a safe and secure installation.
- Improper fuses can cause damage or fire. When you need to change the fuse, consult a professional.

Note on the power supply lead (yellow)

- When you connect other devices to this apparatus, ensure that the rating of the car circuit is higher than the total fuse value of all the connected devices.

Notes on speaker connection

- Never connect speaker wires to the metal body or chassis of the car.
- Never connect speaker wires with stripes to one another.

Overview of parts

These are the supplied parts needed to connect and install this unit.

- ① In-car audio system
- ② Sleeve
- ③ Front panel
- ④ Trim plate
- ⑤ Rubber cushion
- ⑥ Disassembly tools
- ⑦ Screws (4 pieces)
- ⑧ ISO connector

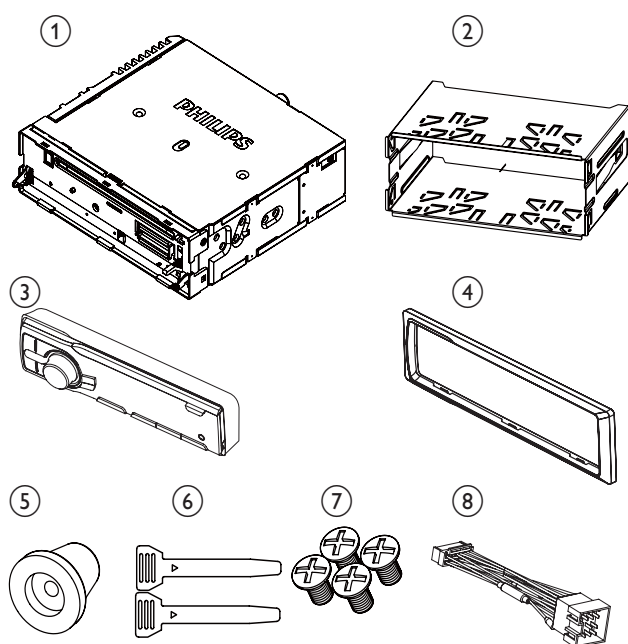

Connection: for cars with ISO connectors



Caution

- Ensure that all loose leads are insulated with electrical tape.

- 1 Pull out the ISO connectors from car dashboard and connect them to the bigger end of the supplied standard connector.

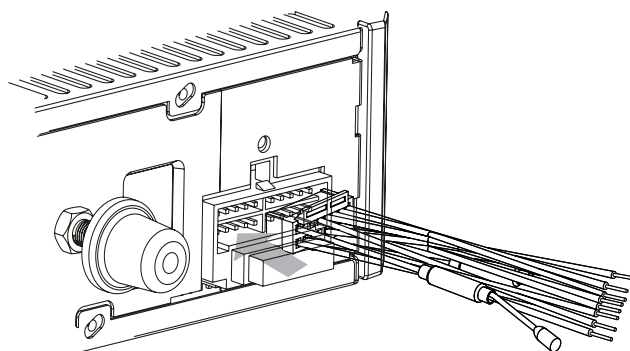

- 2 Connect the other end of the supplied standard connector to the unit.

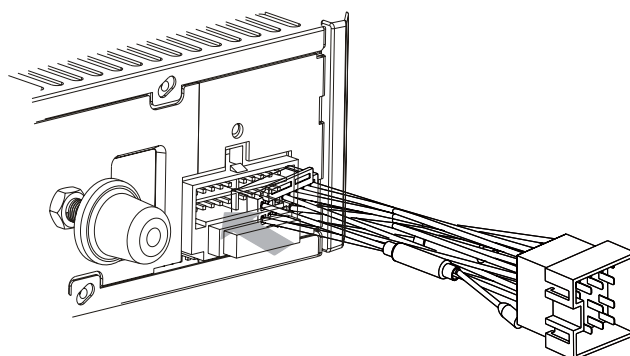

- 3 Connect the antenna and amplifier as illustrated, if applicable. You can connect the car audio to the amplifier through RCA-TO-RCA cables (not supplied).

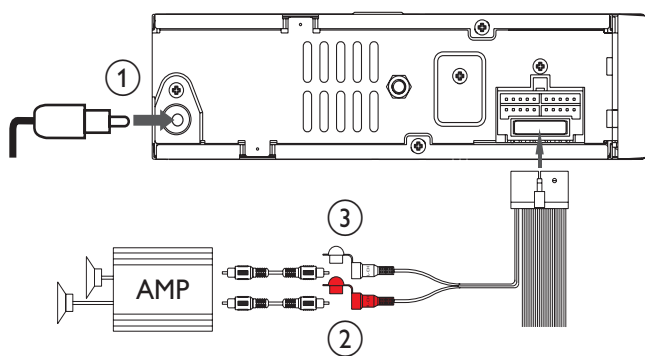

Connector	Connect to
1 ANTENNA	Antenna
2 REAR LINE OUT R	Rear right speaker
3 REAR LINE OUT L	Rear left speaker

Connection: for cars without ISO connectors

! Caution

- Be sure to connect the black ground (earth) lead first.

1 Connect the antenna and amplifier as illustrated, if applicable.

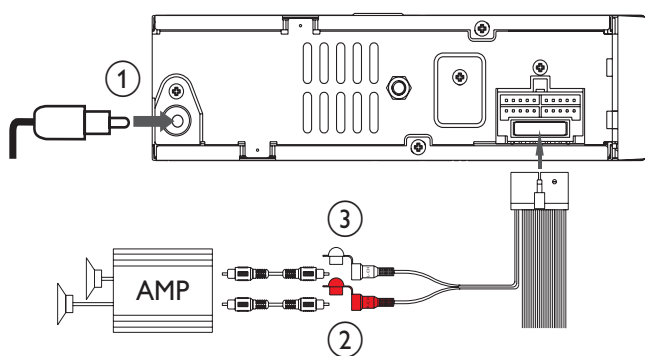

Connector	Connect to
1 ANTENNA	Antenna
2 REAR LINE OUT R	Rear right speaker
3 REAR LINE OUT L	Rear left speaker

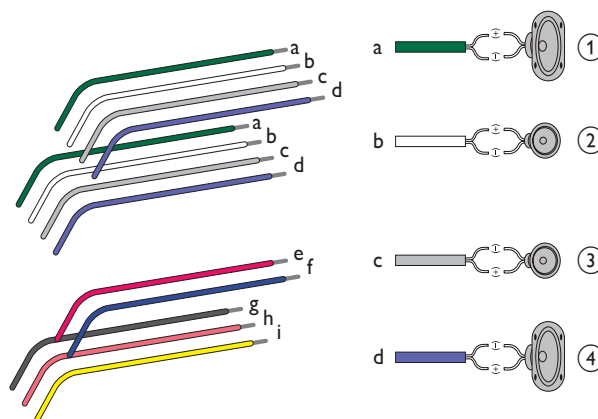

- 2 Cut off the bigger end of the supplied standard connector.
- 3 Check the car's wiring carefully and connect them to the supplied standard connector.

1	Green/black strip	Left speaker (Rear)
2	White/black strip	Left speaker (Front)
3	Gray/black strip	Right speaker (Front)
4	Purple/black strip	Right speaker (Rear)

e	RED	Ignition key +12V DC when ON/ACC
f	BLUE	Motor/electric antenna relay control lead/Amplifier relay control lead
g	BLACK	Ground
h	ORANGE	Illumination switch
i	YELLOW	To the +12V car battery which is energized at all times

4 Connect the supplied standard connector to the unit.

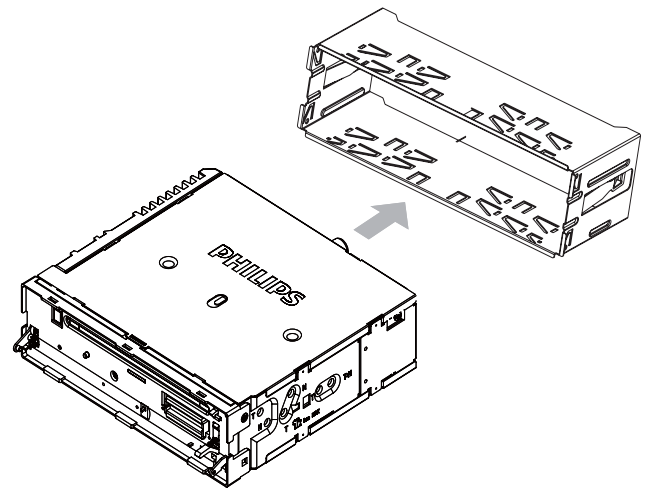
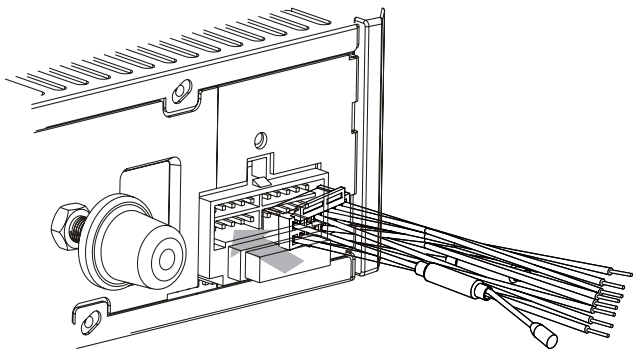

Tip

- The pin arrangement for the ISO connectors depends on the type of vehicle you drive. Make sure to make the proper connections to prevent damage to the unit.

4 Ensure that car dashboard opening is within these measurements:

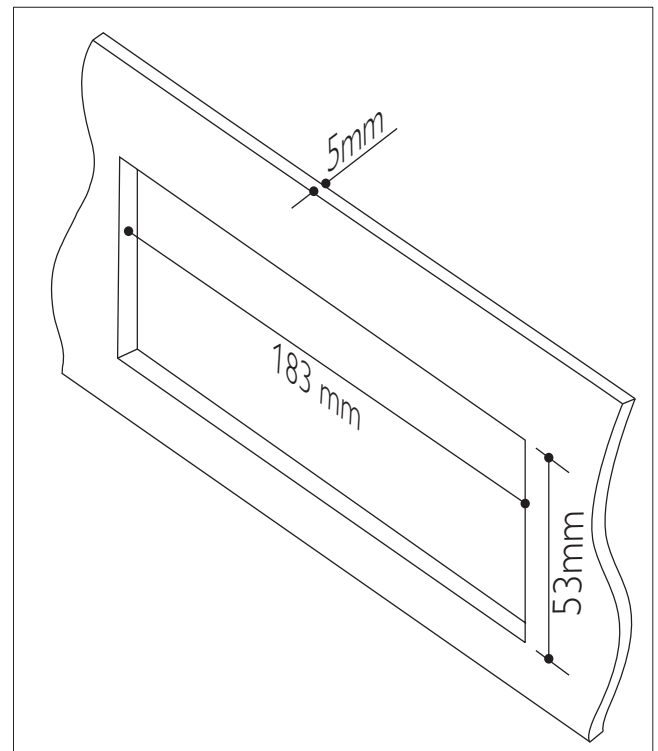

Mount in the dashboard

- 1** If the car does not have an on-board drive or navigation computer, disconnect the negative terminal of the car battery.
 - If you disconnect the car battery in a car that has an on-board drive or navigation computer, the computer may lose its memory.
 - If the car battery is not disconnected, to avoid short-circuit, ensure that bare wires do not touch each other.
- 2** Remove the two screws on the top of the unit.

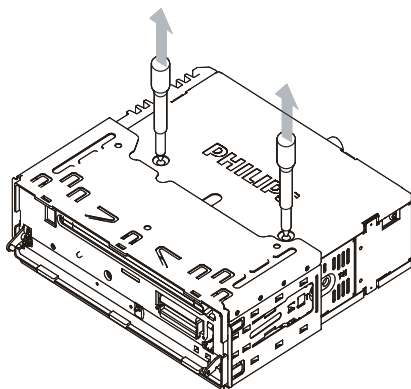

5 Install the sleeve into the dashboard and bend the tabs outward to fix the sleeve.

Note

- Skip this step if the unit is not fixed by sleeve but by supplied screws.

3 Remove the mounting sleeve with the supplied disassembly tools.

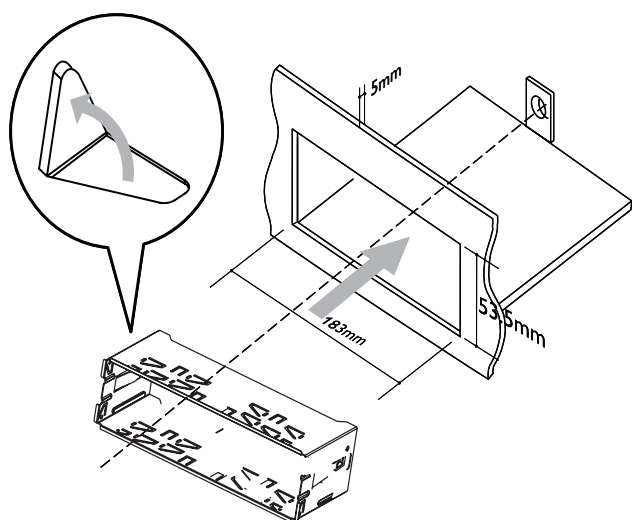

- 6 Place the supplied rubber cushion over the end of the mounting bolt.

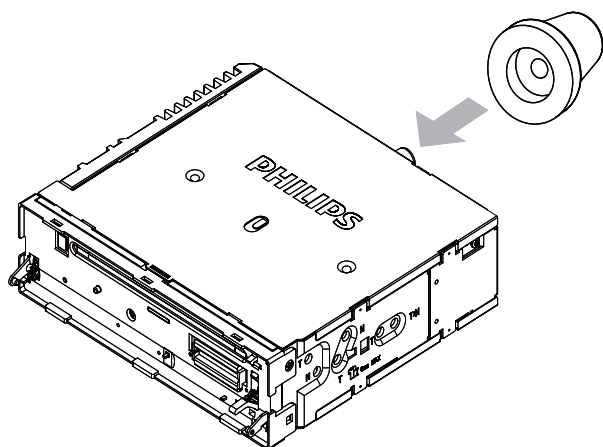

- 7 Slide the unit into the dashboard until you hear a click sound.
- 8 Reconnect the negative terminal of the car battery.

Attach the front panel

- 1 Attach the trim plate.

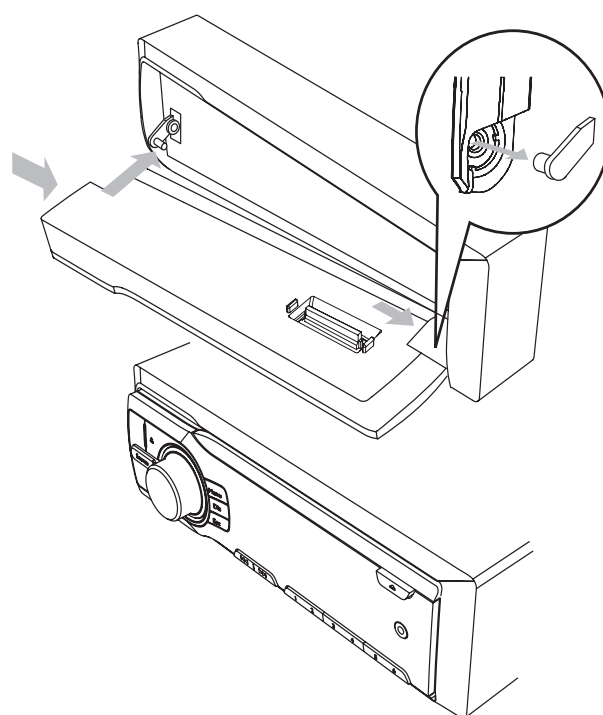

- 2 Insert the right side of the panel in the chassis until it is correctly engaged.
- 3 Press the left side of the panel and point the left hole at the left pillar.
- 4 Release the panel to engage the left side.

Install remote control battery



Caution

- Risk of explosion! Keep batteries away from heat, sunshine or fire. Never discard batteries in fire.
- Risk of decreased battery life! Never mix different brands or types of batteries.
- Risk of product damage! When the remote control is not used for long periods, remove the batteries.
- Perchlorate Material - special handling may apply. See www.dtsc.ca.gov/hazardouswaste/perchlorate.

For first-time use:

- 1 Remove the protective tab to activate the remote control battery.

To replace the remote control battery:

- 1 Open the battery compartment.
- 2 Insert 1 CR2025 batteries with correct polarity (+/-) as indicated.
- 3 Close the battery compartment.

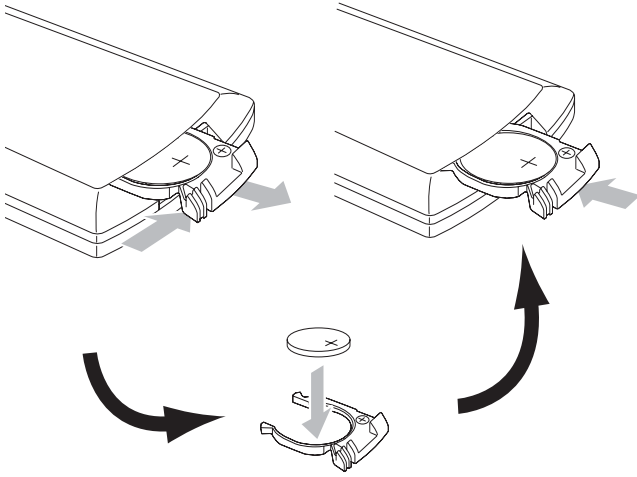

Turn on

- 1 Press **⏻** to turn on the unit.
 - To turn off the unit, press **⏻** for 3 seconds.

Set clock

- 1 Press **MENU/DISP** for 3 seconds.
- 2 Press **▲** or **▼** repeatedly until the currently time is displayed.
- 3 Turn **⌚** clockwise to set hour.
- 4 Press **⌚** to confirm.
- 5 Turn **⌚** anti-clockwise to set minute.
- 6 Press **⌚** to confirm.

View clock

- 1 Press **MENU/DISP** repeatedly until the clock is displayed.

4 Listen to radio

Tune to a radio station

- 1 Press **SOURCE** repeatedly to select Tuner.
- 2 Press **▲** or **▼** to select band: **[FM1]**, **[FM2]**, **[FM3]**, **[AM1]**, or **[AM2]**.
- 3 Press **⏪** or **⏩** to tune to a radio station manually.
 - ↳ The radio station is broadcast.
 - To search for a radio station automatically, press **⏪** or **⏩** for 3 seconds.

Select tuner sensitivity

You can adjust the tuner sensitivity if you want to receive more radio stations or only stations with strong signal.

- 1 Press **MENU/DISP** for over 2 seconds.
- 2 Press **▲** or **▼** repeatedly until **[LOCAL]** or **[DX]** is displayed.
- 3 Rotate **⌚** to select a setting:
 - **[LOCAL]** (local): Only stations with strong signal can be broadcast.
 - **[DX]** (distance): Stations with strong and weak signals can be broadcast.

Select stereo/mono broadcasting

For stations with weak signals: to improve the reception, change to monoaural sound.

- 1 Press **MENU/DISP** for 3 seconds.
- 2 Press **▲** or **▼** repeatedly until **[STEREO]** or **[MONO]** is displayed.
- 3 Turn **⌚** to select a setting:
 - **[STEREO]**: stereo broadcast.
 - **[MONO]**: mono broadcast.

Store radio stations in memory

You can store up to 6 stations in each band.

Store stations automatically

- 1 Press **SEARCH** first, then press **Ⓞ**.
 - ↳ The six strongest stations of the selected band are saved in preset channel automatically: FM1,FM2,FM3 1-6,AM1,AM2.

Store stations manually

- 1 Tune to a station that you want to store. (see 'Tune to a radio station' on page 14)
- 2 Press one of the numbered buttons **1** to **6** for 3 seconds.
 - ↳ The station is saved in the selected channel.

Tune to a preset station

- 1 Press **▲** or **▼** to select band.
- 2 Press the number button **1** to **6** to select the preset station.

5 Play audio files

Note

- Ensure that the disc or device contains playable files.

Play a disc

Note

- You cannot play CDs encoded with copyright protection technologies.

You can play commercially available audio CDs and these discs:

- CD-Recordables (CD-R)
- CD-Re-writables (CD-RW)
- MP3 CDs
- WMA CDs

Note

- Ensure that the disc contains playable content.

- 1 Press **▲** on the front panel to release the panel.
- 2 Insert a CD with the printed side facing up.
- 3 Close the panel.
 - ↳ Play starts automatically.
 - To pause CD play, press **1▶||**.
 - To resume CD play, press **1▶||** again.

Remove the CD

To take out the CD,

- 1 Press **▲**.
- 2 Press **▲** beside the disc slot.

Tip

- If the disc is blocked in the disc compartment, press and hold **▲** until the disc comes out.

Control play

- To select a folder, press ▲ or ▼.
- To skip to the previous/next track, press ◀◀ or ▶▶.
- To search backward/forward rapidly within the current track, press ◀◀ or ▶▶ for 3 seconds.
- To pause, press 1, ▶||.
- To resume play, press 1, ▶|| again.

Search for an MP3/WMA track

- 1 Press **SEARCH**.
 - ↳ Search menu is displayed.
 - ↳ **[FOLD SCH]**: search by folder sequence.
 - ↳ **[FILE SCH]**: search by track name.
- 2 Turn Ⓞ to select **[FILE]** and then press Ⓞ to confirm.
- 3 Turn Ⓞ to enter a character and then press Ⓞ.
- 4 Repeat step 3 until the search term is complete.
- 5 Press Ⓞ for 3 seconds to start search.
 - ↳ When search is finished, a list of matching tracks are displayed.
- 6 Turn Ⓞ to skip over the list.
- 7 Press Ⓞ to select a track.

View play information

- 1 During play, press **MENU/DISP** repeatedly to view:
 - Track number and elapsed play time
 - Artist
 - Album
 - Title
 - Folder
 - File
 - Clock

Intro play

You can play the first 10 seconds of each track.

- 1 During play, press **INTRO, 2** to select:
 - **[INT ON]** : After the first 10 seconds of each track have been played, play stops.
 - **[INT OFF]** : Cancel intro play and start normal play.

Shuffle play

You can play the tracks in random order.

- 1 During play, press **SHUF, 4** to select:
 - **[SHUF ON]**: start shuffle play for all tracks.
 - **[SHUF OFF]**: cancel shuffle play.

Repeat play

- 1 During play, press **3, REP** repeatedly to select:
 - **[RPT TRK]** (repeat one track): play the current track repeatedly.
 - **[RPT DIR]** (repeat a folder): play all tracks in the current folder repeatedly.
 - **[RPT ALL]** (repeat all tracks): play all tracks repeatedly.
 - **[RPT OFF]**: cancel repeat.

Connect external sound source

- 1 Connect the external sound source to **MP3 LINK** socket with a 3.5 mm cable.
- 2 Press **SOURCE** repeatedly until **[MP3 LINK]** is displayed.
- 3 Operate the external component (refer to the instructions supplied with the external component).

6 Adjust sound

Adjust volume

- 1 Turn \odot clockwise/anticlockwise to increase/decrease volume.

Mute

You can turn off the sound of your audio.

- 1 During play, press **MUTE** \odot .
 - To turn the sound back on, press **MUTE** \odot again.

Turn Dynamic Bass Boost (DBB) on/off

- 1 Press **DBB**, the current setting is displayed:
 - ↳ **[DBB ON]** :The Dynamic Bass Boost (DBB) function is on.
 - ↳ **[DBB OFF]** :The DBB function is off.
- 2 Press **DBB** again to change the DBB setting.

Select preset equalizer

- 1 Press **EQ/Audio**.
 - ↳ The current Equalizer setting is displayed.
- 2 Press **EQ/Audio** again repeatedly to select a preset EQ:
 - **[OPTIMAL]** (optimal)
 - **[FLAT]** (flat)
 - **[POP]** (pop)
 - **[USER]** (user)
 - **[TECHNO]** (techno)
 - **[ROCK]** (rock)
 - **[CLASSIC]** (classic)
 - **[JAZZ]** (jazz)

Other sound settings

You can also edit user preset EQ.

- 1 Press **EQ/Audio** for 3 seconds.
- 2 Press \blacktriangle or \blacktriangledown repeatedly to select the item to be adjusted:
 - **[BAS]** (bass) range: -7 to +7.
 - **[TRE]** (treble) range: -7 to +7.
 - **[BAL]** (balance) range: 12L to 12R. (L = left speaker, R = right speaker)
 - **[FAD]** (fader) range: 12R to 12F. (R = rear speaker, F = front speaker)
- 3 Turn \odot to select a value.

7 Adjust system settings

Turn demo mode on/off

When demo mode is on, when the unit is idle for more than 2 minutes, all functions are displayed.

- 1 Press **MENU/DISP** for 3 seconds.
- 2 Press **▲** or **▼** repeatedly to until **[DEMO]** is displayed.
↳ The screen shows current Demo mode setting.
- 3 Turn **⊖** to select a setting:
 - **[DEMO ON]** : Turn on the demo mode.
 - **[DEMO OFF]** : Turn off the demo mode.

Select start volume

Each time you turn on the unit, it can play at the last listened volume or at the preset volume.

- 1 Press **MENU/DISP** for 3 seconds.
- 2 Press **▲** or **▼** repeatedly to until **[V - LAST]** or **[V - ADJ]** is displayed.
- 3 Turn **⊖** to select a setting:
 - **[V - LAST]** : Each time you turn on the unit, the volume remains from its previous use.
 - **[V - ADJ]** : Each time you turn on the unit, the volume is at the preset level.

Store preset volume

You can turn on the unit at a preset volume.

- 1 Select **[V - ADJ]** as the start volume.
- 2 Press **MENU/DISP** for 3 seconds.

- 3 Press **▲** or **▼** repeatedly to until **[A-VOL]** is displayed.
- 4 Turn **⊖** to select a value: 0 - 47.

Turn beep sound on/off

Each time you press a button, the unit beeps. You can turn off/on this beep sound.

- 1 Press **MENU/DISP** for 3 seconds.
- 2 Press **▲** or **▼** repeatedly to until **[BEEP ON]** or **[BEEP OFF]** is displayed.
- 3 Rotate **⊖** to select a setting:
 - **[BEEP ON]**: Turn on the beep sound.
 - **[BEEP OFF]**: Turn off the beep sound.

Turn display scroll on/off

For track information that is longer than the display panel: you can select to cut off the remainder of the text, or scroll to display the full text.

Note

- If any special characters are present in the MP3 track name or album name, it may not display correctly on the screen because these characters are not supported.
- Some WMA is protected by Digital Rights Management (DRM), it cannot be played on the unit.
- Folders/files exceed the supported limit of the unit are not displayed or played.

- 1 Press **MENU/DISP** for 3 seconds.
- 2 Press **▲** or **▼** repeatedly to until **[ROLL ON]** or **[ROLL OFF]** is displayed.
- 3 Turn **⊖** to select a setting:
 - **[ROLL ON]** (scroll on): Auto scroll during play.
 - **[ROLL OFF]** (scroll off): No auto scroll display.

Select shock-protect setting

You can select the shock protection setting, depending on the stability of your car and the condition of the road.

- 1 Press **MENU/DISP** for 3 seconds.
- 2 Press **▲** or **▼** repeatedly until **[ESP]** is displayed.
- 3 Turn **⊖** to select a setting:
 - **[ESP 10 S]**: select this when the road is smooth and there are few bumps.
 - **[ESP 40 S]**: select this when the road is bumpy and unstable.

Reset

You can reset the unit to its default setting.

- 1 Detach the front panel (see 'Detach the front panel' on page 19).
- 2 Press the reset button by using a ball-point pen or a similar tool.
 - ↳ Preset adjustments such as preset channels and sound adjustments are erased.

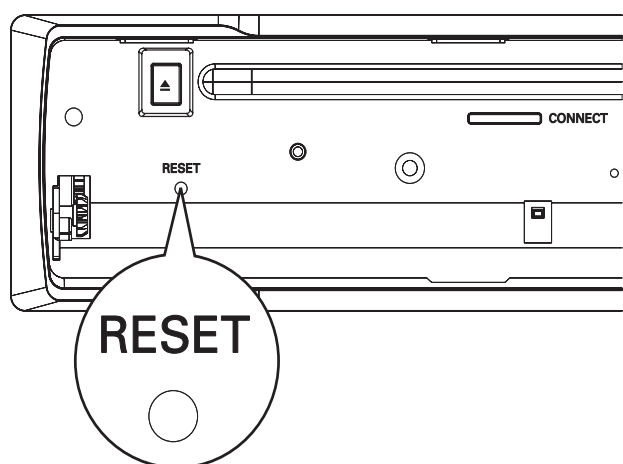

8 Additional information

Detach the front panel

You can detach the front panel to deter theft.

- 1 Press **▲** to release the panel.
- 2 Press the left side of the panel rightward.

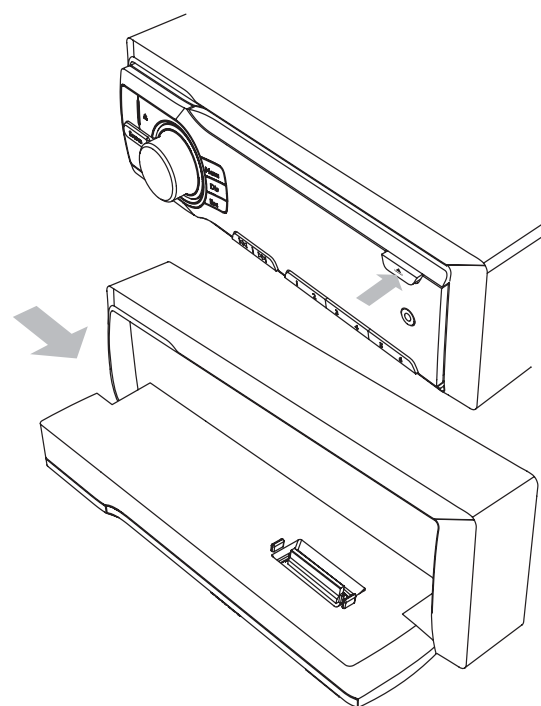

- 3 Pull the panel towards you to detach it from the chassis.
- 4 Store the panel in the supplied carry case to protect it from dirt or damage.

Replace fuse

If the fuse is damaged,

- 1 Check the electric connection.
- 2 Buy a fuse that matches the voltage of the damaged fuse.
- 3 Replace the fuse.

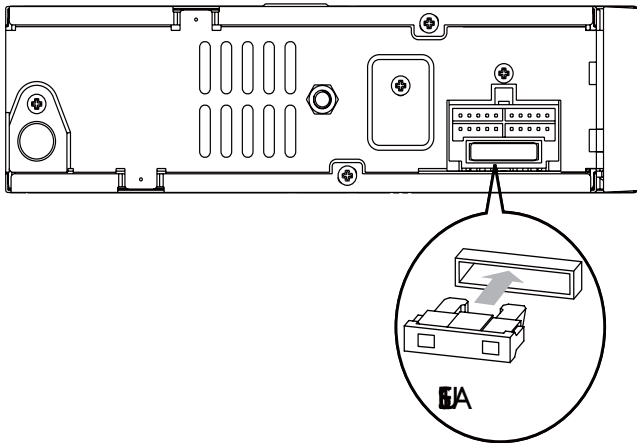

Note

- If the new fuse gets damaged again, there may be an internal malfunction. Consult your Philips dealer.

Remove the unit

You can remove the unit from the dashboard.

- 1 Detach the front panel.
- 2 Pull out the unit by using the removal keys.

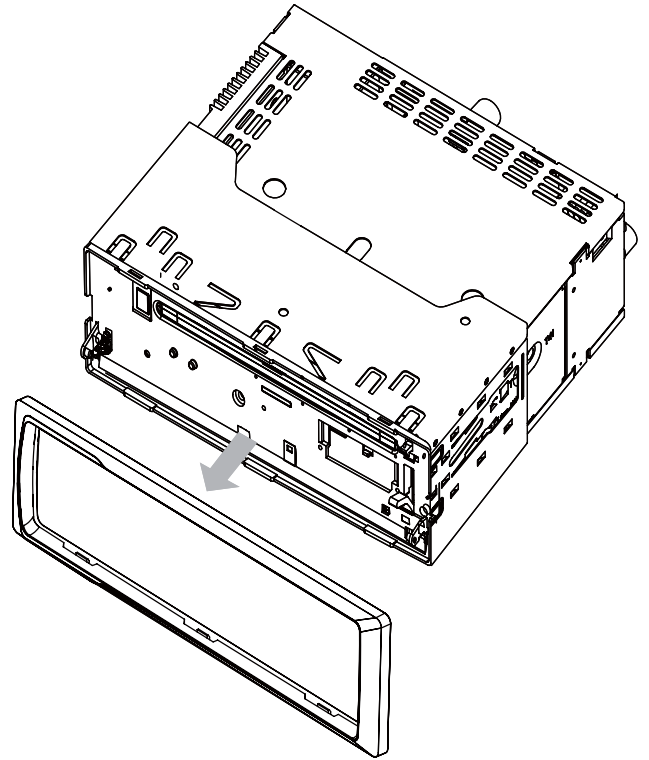

9 Product information

Note

- Product information is subject to change without prior notice.

Power supply	12 V DC (11 V - 16 V), negative ground
Fuse	15 A
Suitable speaker impedance	4 - 8 Ω
Maximum power output	45 W \times 4 channels
Continuous power output	22 W \times 4 RMS (4 Ω 10% T.H.D.)
Pre-Amp output voltage	2.0 V
Aux-in level	\geq 500 mV
Dimensions (W \times H \times D)	188 \times 58 \times 206 mm
Weight	1.57 kg

Radio

Frequency range - FM	87.5 - 108.0 MHz (100 kHz per step in auto search and 50 kHz per step in manual search)
Frequency range - AM(MW)	522 - 1620 KHz (9 KHz) 530 - 1710 KHz (10 KHz)
Usable sensitivity - FM	8 μ V
Usable sensitivity - AM(MW) (S/N = 20 dB)	30 μ V

10 Troubleshooting



Caution

- Never remove the casing of this apparatus.

To keep the warranty valid, never try to repair the system yourself.

If you encounter problems when using this apparatus, check the following points before requesting service. If the problem remains unsolved, go to the Philips web site (www.philips.com/support). When you contact Philips, ensure that your apparatus is nearby and the model number and serial number are available.

No power or no sound.

- Car engine is not on. Turn the car engine on.
- Cable is not correctly connected. Check connections.
- Fuse is burnt. Replace fuse.
- Volume is too low. Adjust volume (see 'Adjust volume' on page 17).
- If the above solutions cannot help, press the RESET button.
- Ensure that the track played is of a compatible format.

Noise in broadcasts.

- Signals are too weak. Select other stations with stronger signals.
- Check the connection of the car antenna.
- Change broadcast from Stereo to mono.

Cannot play disc

- Ensure that the disc label is inserted with the printed side facing up.
- Wipe the disc with fibre cleaning cloth from the centre to the edge in a straight line.
- This disc may be defective. Play another disc.
- Ensure that the CD is a finalised CD/CD-R/CD-RW.
- Ensure that the CD is not encoded with copyright protection technologies.

The CD skips tracks

- Ensure that the CD is not damaged or dirty.
- Ensure that random mode is deactivated.

Disc cannot be ejected

- Press and hold ▲.

Preset stations lost.

- Battery cable is not correctly connected. Connect the battery cable to the terminal that is always live.

11 Glossary

M

MP3

A file format with a sound data compression system. MP3 is the abbreviation of Motion Picture Experts Group 1 (or MPEG-1) Audio Layer 3. With the MP3 format, one CD-R or CD-RW can contain about 10 times more data than a regular CD.

W

WMA (Windows Media Audio)

An audio format owned by Microsoft, is a part of Microsoft Windows Media technology. Includes Microsoft Digital Rights Management tools, Windows Media Video encoding technology, and Windows Media Audio encoding technology.

Certificado de Garantía en Argentina

Artefacto:

Modelo:

**Fabricante/Importador: Philips Argentina S.A.
y/o Fábrica Austral de Productos Eléctricos S.A.**

Dirección: Vedia 3892 - Buenos Aires

Fecha de Venta:

	Nro. de serie
--	----------------------

Firma y sello de la casa vendedora.

PHILIPS ARGENTINA S.A. en adelante denominada “la empresa”, garantiza al comprador de este artefacto por el término de (6) meses a partir de la fecha de adquisición, el normal funcionamiento contra cualquier defecto de fabricación y/o vicio de material, y se compromete a reparar el mismo —sin cargo alguno para el adquirente— cuando el mismo fallare en situaciones normales de uso y bajo las condiciones que a continuación se detallan:

1. Este certificado de garantía es válido únicamente en la Republica Argentina. El certificado debe ser completado por la casa vendedora y ser presentado por el usuario conjuntamente con la factura original de compra.
2. Serán causas de anulación de esta garantía en los casos que corresponda:
 - 2.1. Uso impropio o distinto del uso doméstico.
 - 2.2. Exceso o caídas de tensión eléctrica que impliquen uso en condiciones anormales.
 - 2.3. Instalación y/o uso en condiciones distintas a las marcadas en el “Manual de instalación y uso” que se adjunta a esta garantía.
 - 2.4. Cualquier intervención al artefacto por terceros no autorizados por la empresa.
3. La garantía carecerá de validez si se observare lo siguiente:
 - 3.1. Enmiendas o raspaduras en los datos del certificado de garantía o factura.
 - 3.2. Falta de factura original de compra que detalle tipo de artefacto, modelo, número de serie y fecha que coincida con los del encabezamiento del presente certificado.
4. No están cubiertos por esta garantía los siguientes casos:
 - 4.1. Los daños ocasionados al exterior del gabinete.
 - 4.2. Las roturas, golpes, caídas o rayaduras causadas por traslados.
 - 4.3. Los daños o fallas ocasionados por deficiencias, sobretensiones, descargas o interrupciones del circuito de alimentación eléctrica o rayos, deficiencias en la instalación eléctrica del domicilio del usuario o conexión del artefacto a redes que no sean las especificadas en el Manual de Uso del mismo.
 - 4.4. Las fallas, daños, roturas o desgastes producidos por el maltrato o uso indebido del artefacto y/o causadas por inundaciones, incendios, terremotos, tormentas eléctricas, golpes o accidentes de cualquier naturaleza.
 - 4.5. Las fallas o daños ocasionados en desperfectos en la línea telefónica.
 - 4.6. Las fallas producidas por una mala recepción ocasionada en el uso de una antena deficiente o en señales de transmisión débiles.
5. Las condiciones de instalación y uso del artefacto se encuentran detalladas en el Manual de Uso del mismo.
6. La empresa no asume responsabilidad alguna por los daños personales o a la propiedad al usuario o a terceros que pudieran causar la mala instalación o uso indebido del artefacto, incluyendo en este último caso a la falta de mantenimiento.
7. En caso de falla, el usuario deberá requerir la reparación a la empresa a través del Service Oficial y/o Talleres Autorizados más próximos a su domicilio y cuyo listado se acompaña al presente. La empresa a segura al usuario la reparación y/o reposición de piezas para su correcto funcionamiento en un plazo no mayor a 30 días contados a partir de la fecha de solicitud de reparación, salvo caso fortuito o fuerza mayor

8. Toda intervención del servicio técnico realizada a pedido del usuario dentro del plazo de garantía, que no fuera originada por falla o defecto alguno cubierto por este certificado, deberá ser abonado por el interesado de acuerdo a la tarifa vigente.
9. El presente certificado anula cualquier otra garantía implícita o explícita, por la cual y expresamente no autorizamos a ninguna otra persona, sociedad o asociación a asumir por nuestra cuenta ninguna responsabilidad con respecto a nuestros productos.
10. En caso de que durante el período de vigencia de esta garantía el artefacto deba ser trasladado a las Delegaciones Oficiales y/o Talleres Autorizados de Service para su reparación, el transporte será realizado por la empresa y serán a su cargo los gastos de flete y seguros y cualquier otro que deba realizarse para su ejecución.



PHILIPS

Red de Talleres Autorizados en Argentina

CAPITAL FEDERAL

ATTENDANCE S.A.

- Av. Monroe 3351 (C1430BKA) Cap. Fed.
- Tel.: 4545-5574/0704 ó 6775-1300
- Ventas de Repuestos y Accesorios
- Tel.: 4545-0854

DIG TRONIC

- Av. San Martín 1762 (C1416CRS) Cap. Fed.
- Tel.: 4583-1501

ELECTARG S.R.L.

- Av. Córdoba 1357 (C1055AAD) Cap. Fed.
- Ventas de Repuestos y Accesorios
- Tel.: 4811-1050

Caballito Electarg J. M. Moreno 287 4903-6967/6854/8983

BUENOS AIRES

Azul	Herlein Raúl Horacio	Av. 25 de Mayo 1227	(02281) 428719
Bahía Blanca	Neutron	Soler 535	(0291) 4535329
Bragado	Yacovino Juan J.	San Martín 2141	(02342) 424147
Campana	Electricidad Krautor	Lavalle 415	(03489) 432919
Chivilcoy	Fama	Coronel Suárez 110	(02346) 424129
Junín	Junín Service	Alsina 537	(02362) 442754
La Plata	Da Tos e Hijos	Calle 68 N° 1532	(0221) 4516021
La Plata	Service Técnico La Plata	Av. 51 N° 1051 esq. 16	(0221) 4108155
Mar de Ajó	Tauro Electrónica	Catamarca 14	(02257) 421750
Mar del Plata	Central Service	Olazábal 2249	(0223) 4721639/4729367
Mar del Plata	Service Integral	Diag. Pueyrredón 3229	(0223) 4945633
Necochea	Electrónica Camejo	Calle 63 N° 1745	(02262) 426134
Pehuajó	Calcagni Carlos Alberto	Zubiría 794	(02396) 472665
Pergamino	ACV Sistemas	Dr. Alem 758	(02477) 421177
Pergamino	El Service	Juan B. Justo 1931	(02477) 418000

San Nicolás	Servitec	Bv. Alvarez 148	(03461) 454729/429578
San Pedro	Electrónica Menisale	Mitre 1695	(03329) 425523
Tandil	Lazzarini Oscar Rafael	Pellegrini 524	(02293) 442167
Trenque Lauquen	Labrone Electrónica	Av. San Martín 426	(02392) 423248
Tres Arroyos	Saini Fabián y Sergio	Av. Belgrano 562	(02983) 427369
Zárate	Electrónica Spinozzi	Ituzaingó 1030	(03487) 427353

GRAN BUENOS AIRES

Avellaneda	Casa Torres S.A.	Av. Mitre 2559	4255-5854
Florencio Varela	Casa Torres S.A.	San Martín 2574	4255-5854
Gregorio de Laferrere	Electrónica Alvarez	Honorio Luque 6084	4626-1322
Lomas de Zamora	Attendance S.A. Lomas	Laprida 485	4292-8900
Merlo	Argentónica S.H.	Pte. Cámpora 2175	(0220) 4837177/4829934
Moreno	Argentónica S.H.	Bmé. Mitre 2977 loc.2	(0237) 4639500
Morón	Servotronic	Ntra. Sra. del Buen Viaje 1222	4627-5656
Olivos	Appliance	Av. Libertador 2684	4794-7700
Quilmes	Casa Torres S.A.	E. Ríos esq. Gran Canaria	4255-5854
Ramos Mejía	Electarg S.R.L. Suc.	Belgrano 224	4656-0619
San Miguel	Servotronic San Miguel	Belgrano 999	4664-4131
Villa Ballester	Servotronic	J. Hernández 3101	4767-2515/4768-5249

CATAMARCA

Catamarca	Omicron Central de Serv.	San Martín 225	(03833) 427235
-----------	--------------------------	----------------	----------------

CHACO

Resistencia	Freschi Jorge Oscar	Av. Avalos 320	(03722) 426030
-------------	---------------------	----------------	----------------

CHUBUT

Comodoro Rivadavia	C.A.S. S.R.L.	Alem 145	(0297) 4442629
Trelew	Fagtron Electrónica	Brasil 253	(02965) 427073

CORDOBA

Córdoba Capital	Servelco S.R.L.	Pje. E. Marsilla 635	(0351) 4724008/4732024
Río Cuarto	Maurutto Víctor G.	Bv. Almafuerde 487	(0358) 4660204
Río Cuarto	Capaldi Abel	Paunero 832	(0358) 4623003
Río Tercero	Service Omega	Homero Manzi 149	(03571) 423330
San Francisco	Acuña Walter Electrónica	M. Moreno 360	(03564) 425367
Villa María	Grasso Electrónica	Bv. Alvear 541	(0353) 4521366
Villa María	Vanguard Sist. Electrónicos	México 421	(0353) 4532951

Validez de la garantía

Todos los productos de la línea de audio y video Philips, se registrarán por un año de garantía internacional (365 días), salvo para Chile donde los productos de las líneas CD Portable y RCR CD, los cuales se rigen por 6 meses de garantía (182 días)

Condiciones de la garantía

Esta garantía perderá su validez si:

- El defecto es causado por uso incorrecto o en desacuerdo con el manual de instrucciones
- El aparato sea modificado, violado por una persona no autorizada por Philips
- El producto esté funcionando con un suministro de energía (red eléctrica, batería, etc.) de características diferentes a las recomendadas en el manual de instrucciones
- El número de serie que identifica el producto se encuentre de forma adulterada.

Están excluidos de garantía,

- Los defectos que se generen debido al incumplimiento del manual de instrucciones del producto
- Los casos fortuitos o de la fuerza mayor, como aquellos causados por agentes de la naturaleza y accidentes, descargas eléctricas, señales de transmisión débiles.
- Los defectos que se generen debido al uso de los productos en servicios no doméstico/residencial regulares o en desacuerdo con el uso recomendado
- Daños ocasionados por fluctuaciones de voltajes, voltaje fuera de norma o por causas fuera de Philips, como cortocircuitos en los bafles o parlantes.
- En las ciudades en donde no existe el taller autorizado del servicio de Philips, los costos del transporte del aparato y/o el técnico autorizado, corren por cuenta del cliente.
- La garantía no será válida si el producto necesita modificaciones o adaptaciones para que funcione en otro país que no es aquél para el cual fue mercadeado.

El único documento válido para hacer efectiva la garantía de los productos, es la Factura o Boleta de compra del consumidor final.

Aquellos productos que hayan sido adquiridos en otros países y que no estén en el rango normal del país donde se efectuará la reparación, dicha prestación de servicio tomará mas tiempo de lo normal ya que es necesario pedir las partes/piezas al centro de producción correspondiente.

Centros de información

Líneas de atención al consumidor

Chile: 600-7445477

Colombia: 01-800-700-7445

Costa Rica: 0800-506-7445

Ecuador: 1-800-10-1045

El Salvador: 800-6024

Guatemala: 1-800-299-0007

Panama: 800-8300

Peru: 0800-00100

Rep. Dominicana: 1-800-751-2673

Venezuela: 0800-100-4888

