

8" Active Aluminum Subwoofer

Service
Service
Service

NBF83A

Service Manual

Contents

1. Specifications	2
2. Sch Block Diagram	3
3. Schematic Diagram	4,5
4. Amplifier PCB	
Control PCB	6,7,8,9
Power PCB	10,11,12
5. Packaging Exploded Drawing	13
6. Mechanical Exploded View	14

Sch Block Diagram

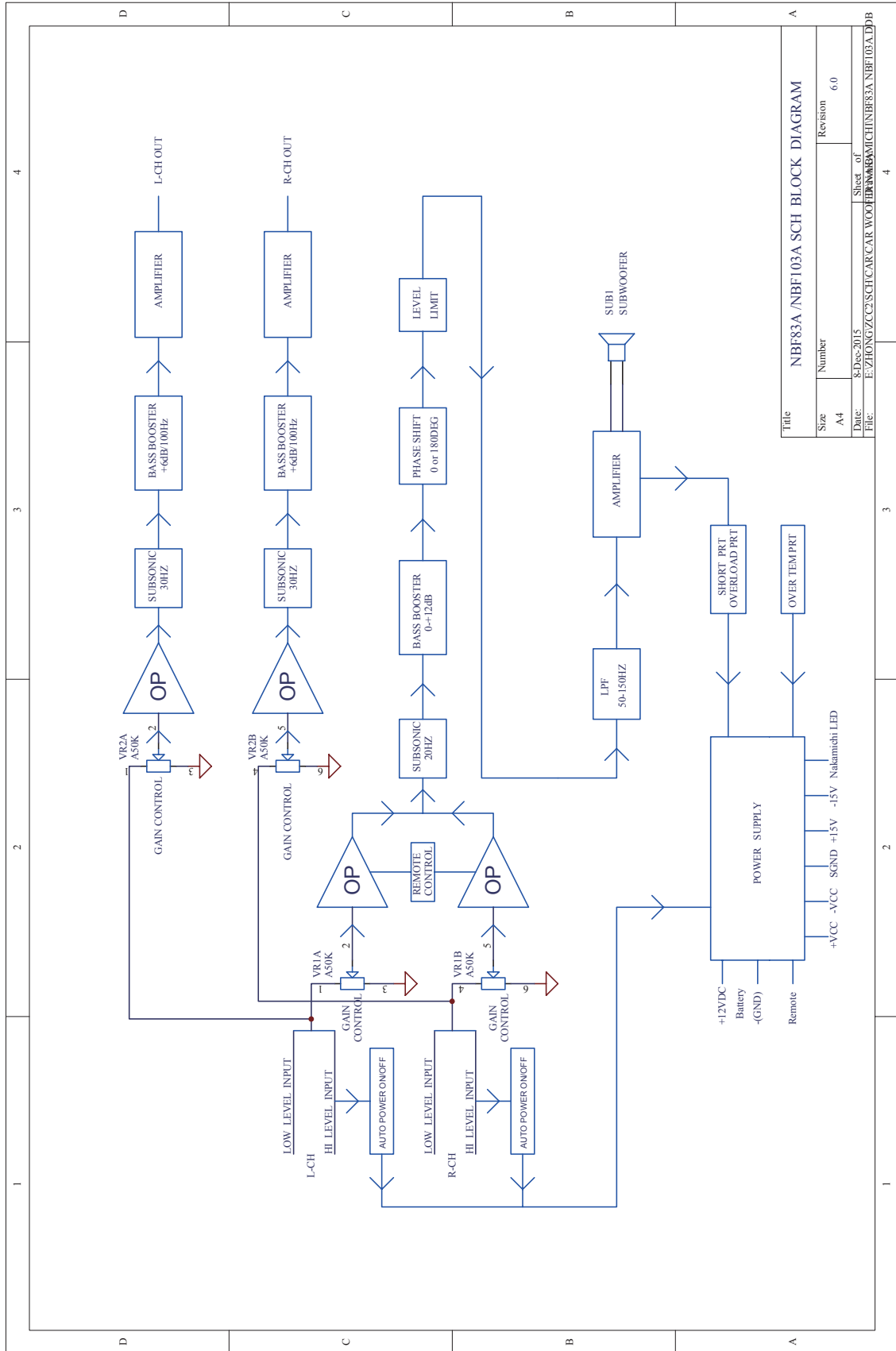

Schematic Diagram

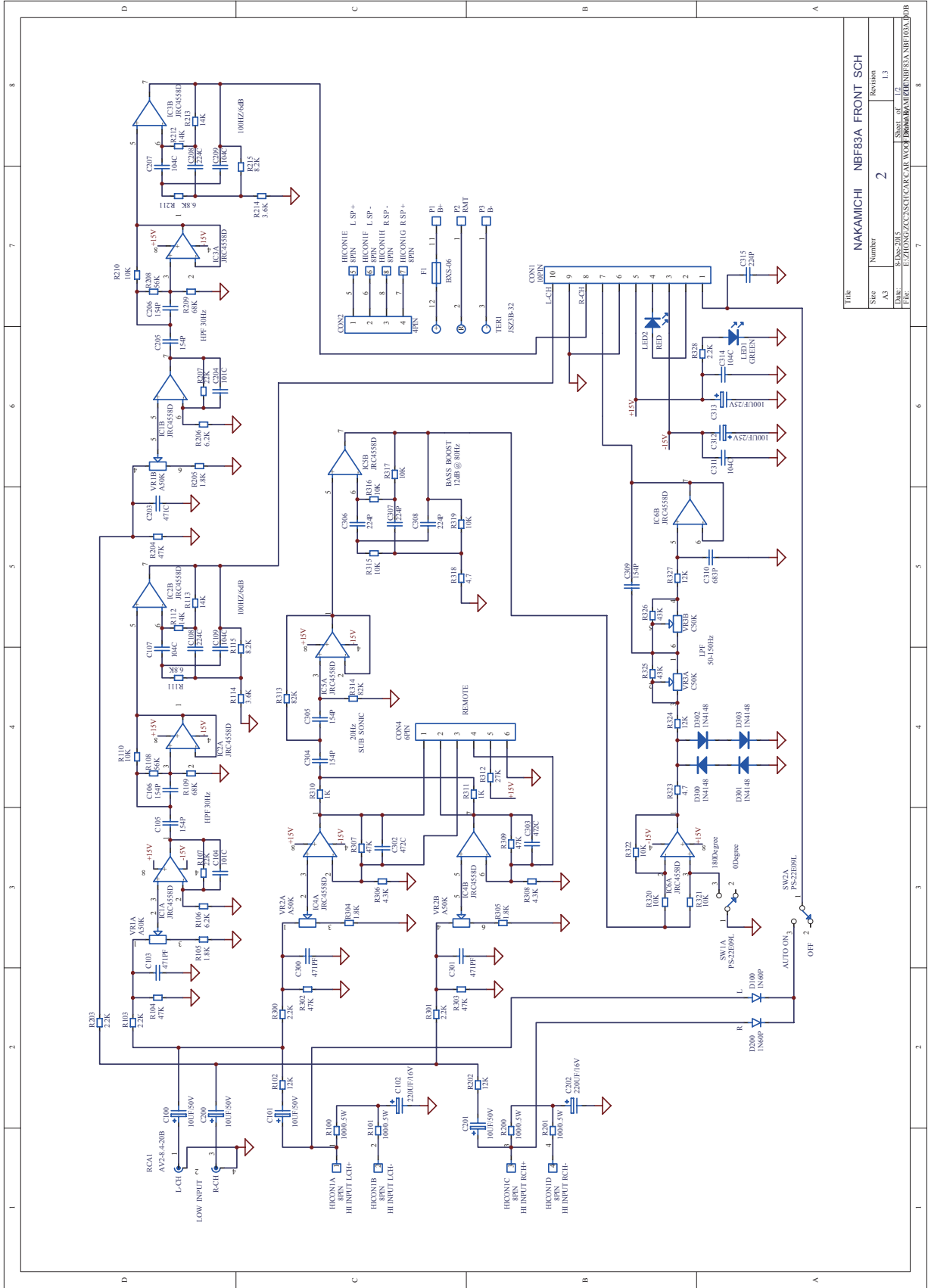

Title			
NAKAMICHI	NBF89A	FRONT SCH	
Size	Number	Revision	
A3	2	1.3	
Date	3/15/2015	Sheet of	17
File	E:\ZUNOUG\ZSCH\CAK\K.WOCH\PRNAKAMICHI\NBF89A\FRONT SCH.D09		

Control PCB Bottom Layer

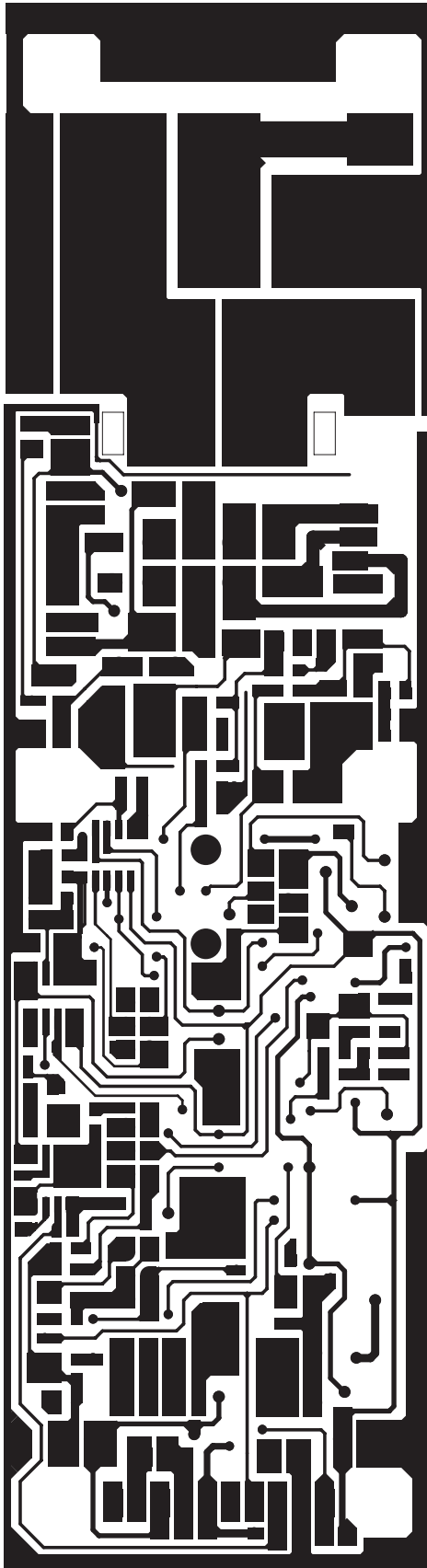

Control PCB TOP Layer

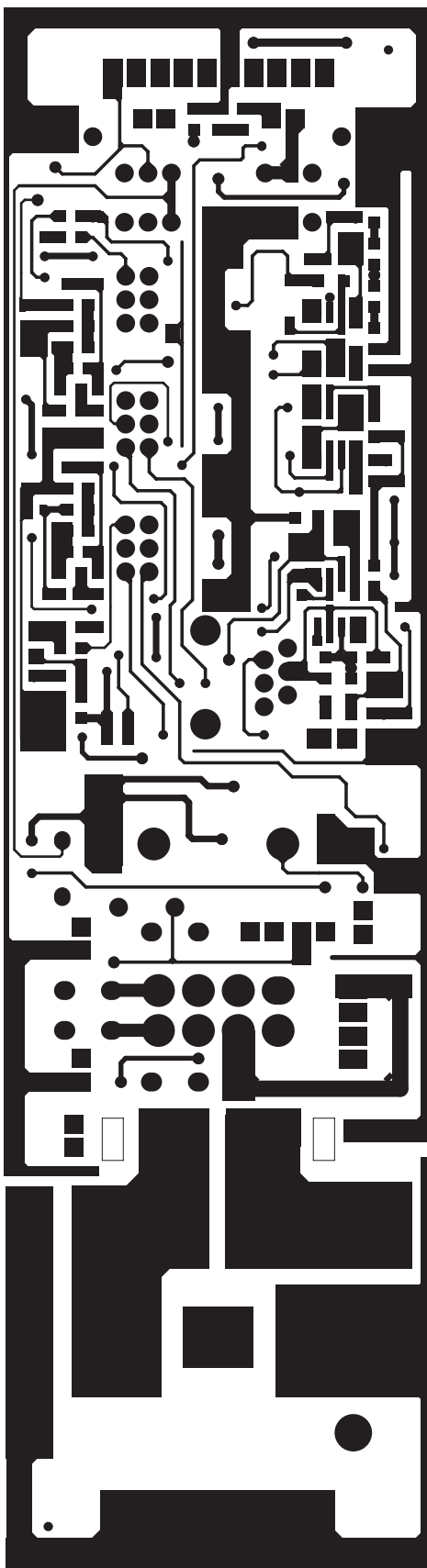

Control PCB Bottom Silk

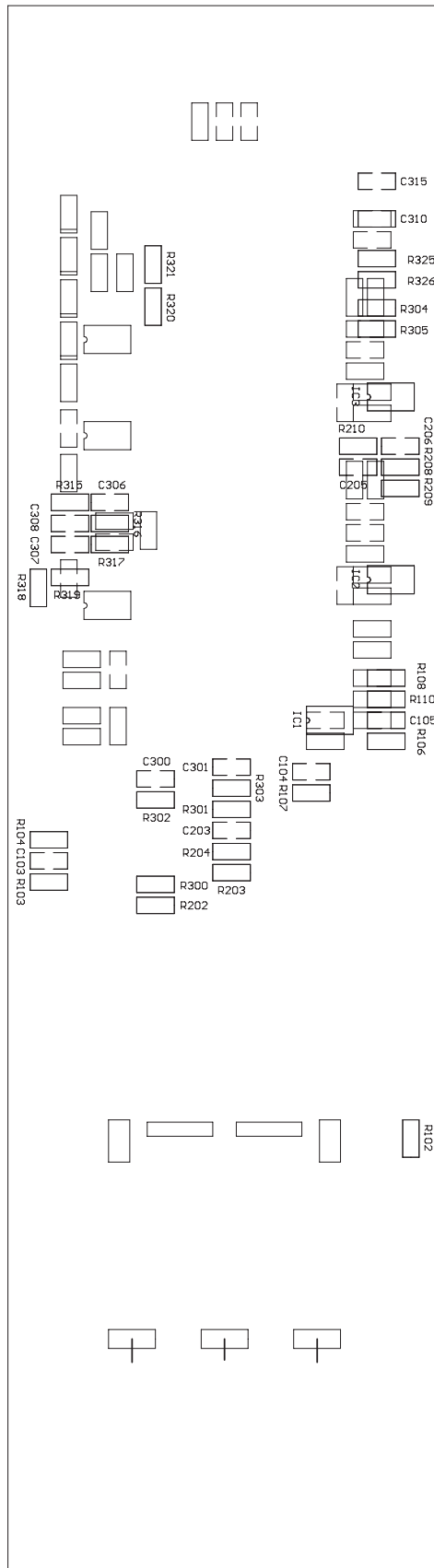

Power PCB Bottom Layer

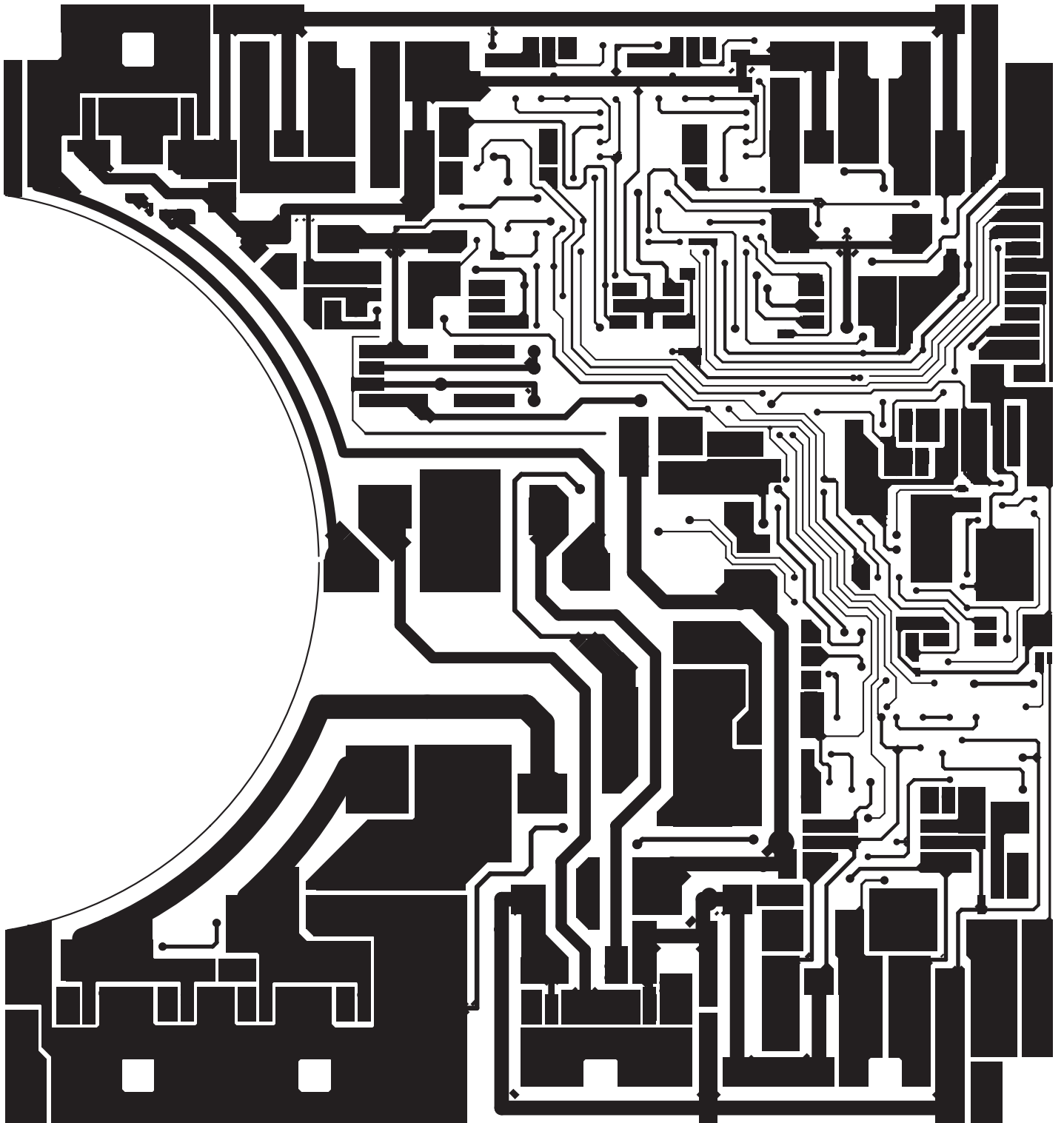

Power PCB Top Layer

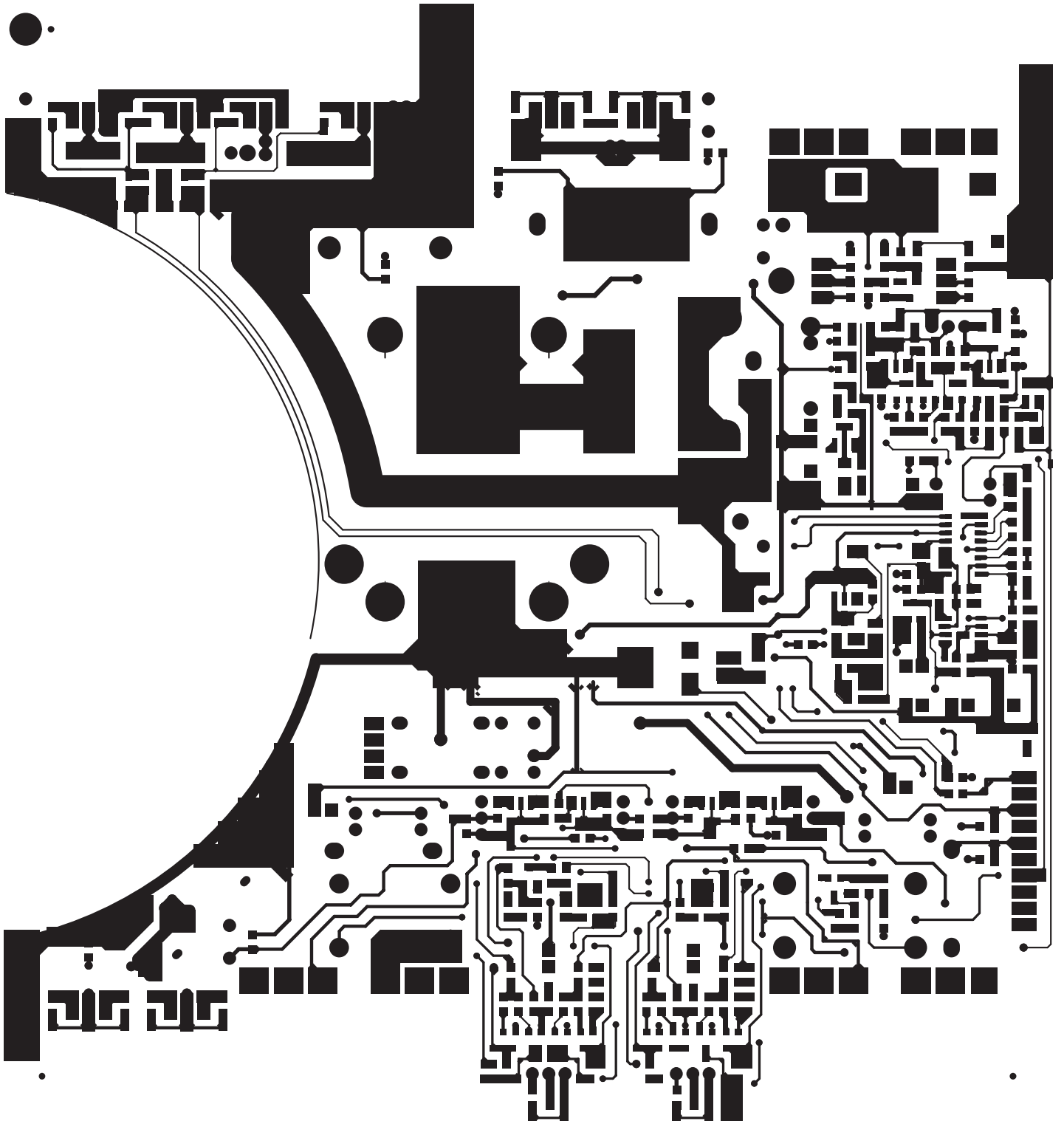

Power PCB Top Silk

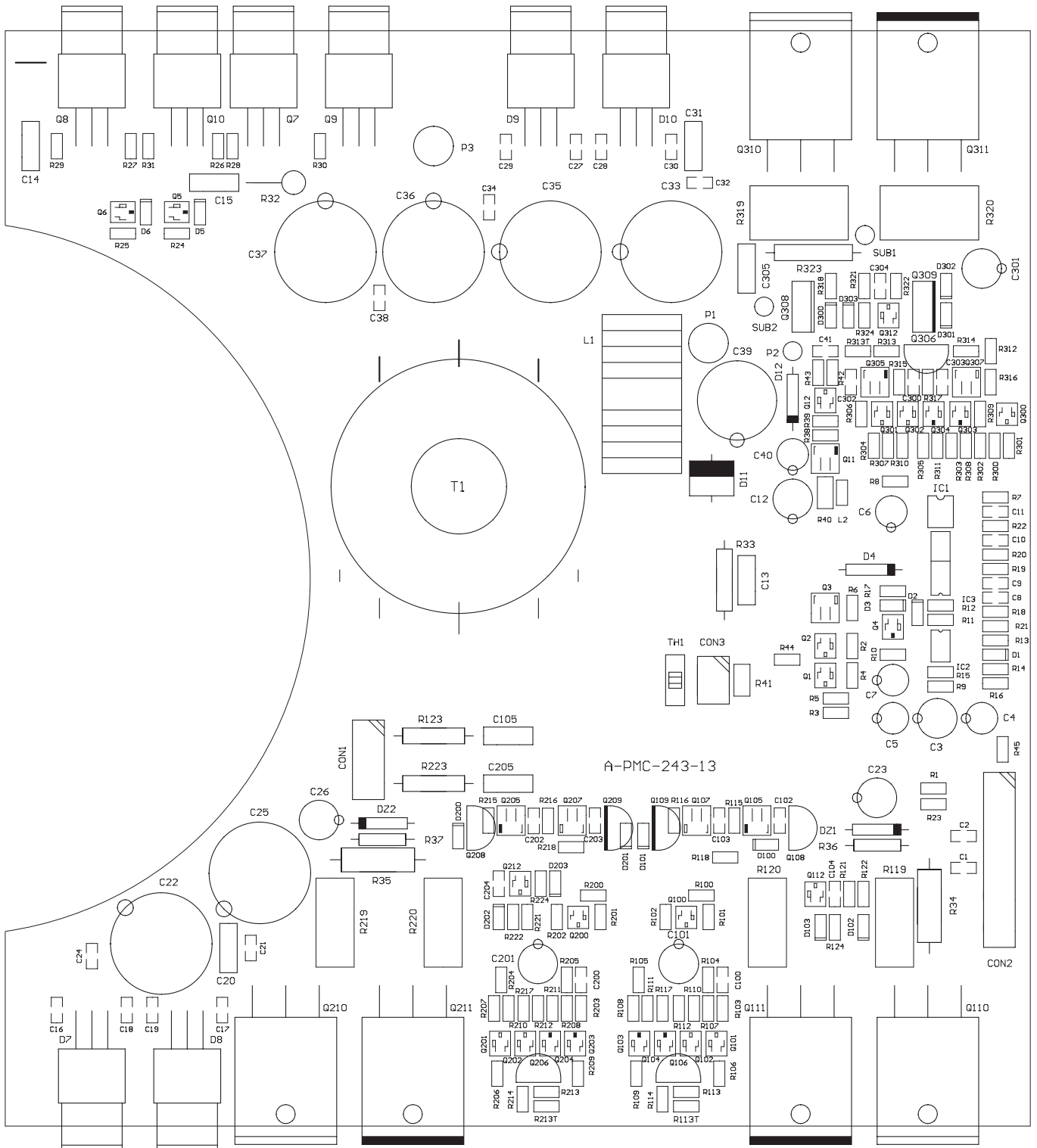

Packaging exploded Drawing

NBF83A Packaging exploded Drawing

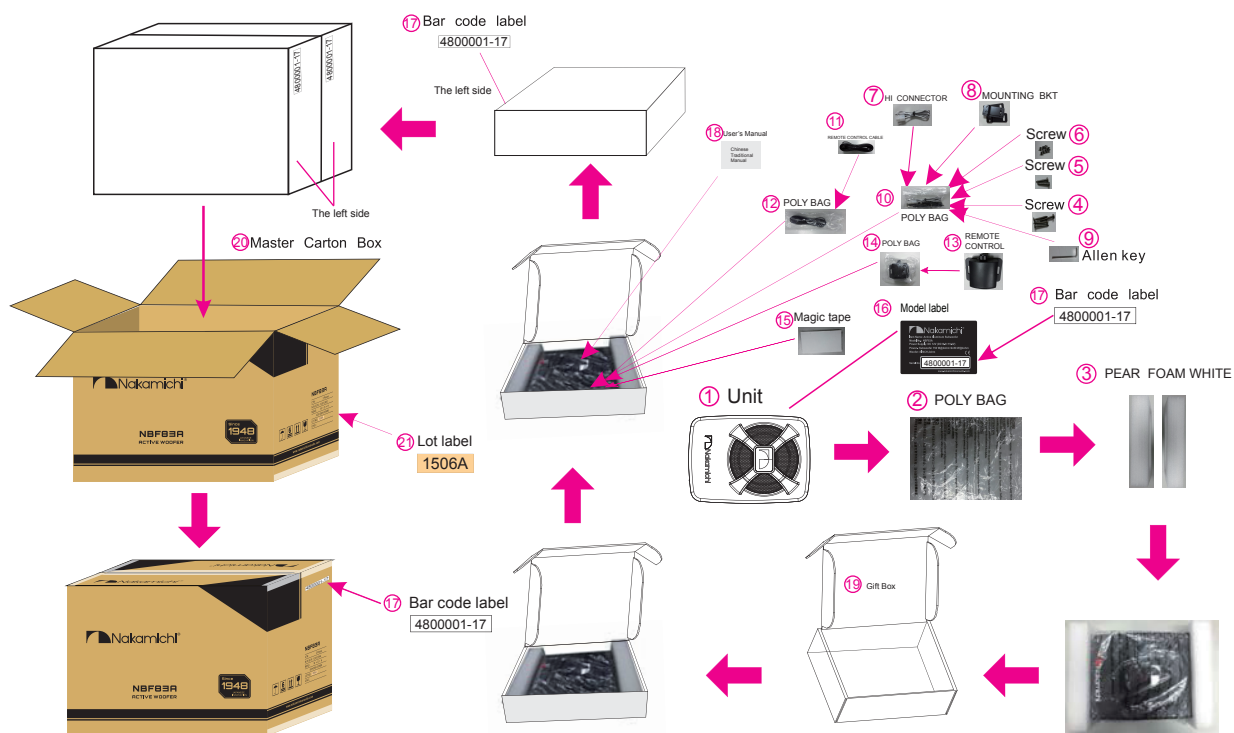

NO.	Part No	Part Name	QTY	REMARK	NO.	Part No	Part Name	QTY	REMARK
①	NBF83A	Unit	1		⑫	A-YOVB-10013005	Poly bag	1	
②	A-YOVB-37053005	Poly bag	1		⑬	REMOTE2N	Remote control	1	
③	A-YPSB-0043-02	Pear foam	2		⑭	A-YOVB-16025006	Poly bag	1	
④	XHTA-04+25CB	SCREW	4		⑮	MGT1200002	Magic tape	1	
⑤	XHBT-03+14CB	SCREW	2		⑯	A-MLNK-NBF83A-01	Model label	1	
⑥	XHBM-04+06CB	SCREW	8		⑰	A-SLNK-NBF83A-02	Bar code label	3	
⑦	A-HMHB6-017A	HI CONNECTOR	1		⑱	A-IMNK-NBF83A-03	Manual	2	
⑧	A-APBK-0054-01B	MOUNTING BKT	1		⑲	A-WBNK-NBF83A-02	Gift Box	1	
⑨	XHWT-03CN	ALLEN key	1		⑳	A-CTNK-NBF83A-02	Master Carton Box	1/2	
⑩	A-YOVB-16025005	Poly bag	1		㉑	A-MLNK-NBF83A-03	Lot label	2/2	
⑪	REMOTE2NW	Remote control cable	1						

Mechanical Exploded View

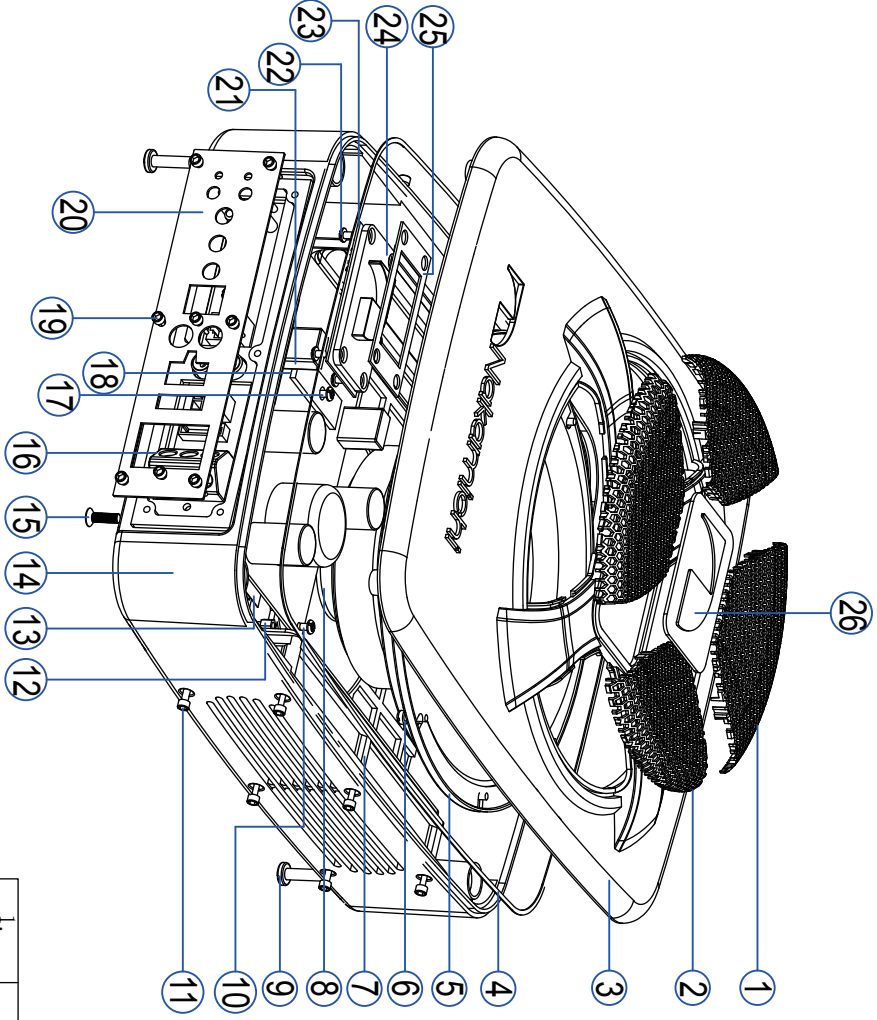

26	A-NPK-0069-02B	LOGO铭牌	1
25	A-APSP-0076-02	EVA	1
24	A-AABS-007-01	LED 灯罩	1
23	A-PFC-163-12	LED PCB	1
22	LS0200300021	螺丝	4
21	A-PFC-171-13	PCBA功放板	1
20	A-APPL-0310-01B	铁面板	1
19	LS0200300003	螺丝	8
18	A-APBK-0050-01N	压片	7
17	LS02003000046	螺丝	7
16	A-PMC-243-12	PCBA控制电路板	1
15	LS0200200020	螺丝	1
14	A-APHS-0280-03B	铸铝底座	1
13	JDM200100003	云母片	2
12	TZ0200100001	铜柱	5
11	LS0200100024	螺丝	12
10	LS0200300022	螺丝	5
9	LS0200400008	螺丝	5
8	A-APSB-0032-01	橡胶垫	1
7	LB000200002	假体喇叭	2
6	LS0200500021	喇叭	8
5	LB000100001	EVA密封条	1
4	A-APHS-0279-02B	铸铝上盖	1
3	A-APGL-08-09B	扇形铁网B	2
2	A-APGL-08-10B	扇形铁网A	2
1		名称	用量

1.	PART NO.	MATERIAL	BLACK 1	VL. 0
NO.			FINISH	TY VERSION
GRAPHICS		SCALE	1/1	爆炸图
APPROVED BY		PART NAME		
DESIGNED BY		UNIT	mm/m	NBF83A
		MODEL		
		DATE	2015-12-09	
Sound Great Industrial Limited				

MARR	REVISION	RECORD	DATE	DRAWN	APPROVED