

10" Active Aluminum Subwoofer

Service
Service
Service

NBF103A

Service Manual

Contents

1. Specifications	2
2. Sch Block Diagram	3
3. Schematic Diagram	4,5
4. Amplifier PCB	
Control PCB	6,7,8,9
Power PCB	10,11,12
5. Packaging Exploded Drawing	13
6. Mechanical Exploded View	14

Sch Block Diagram

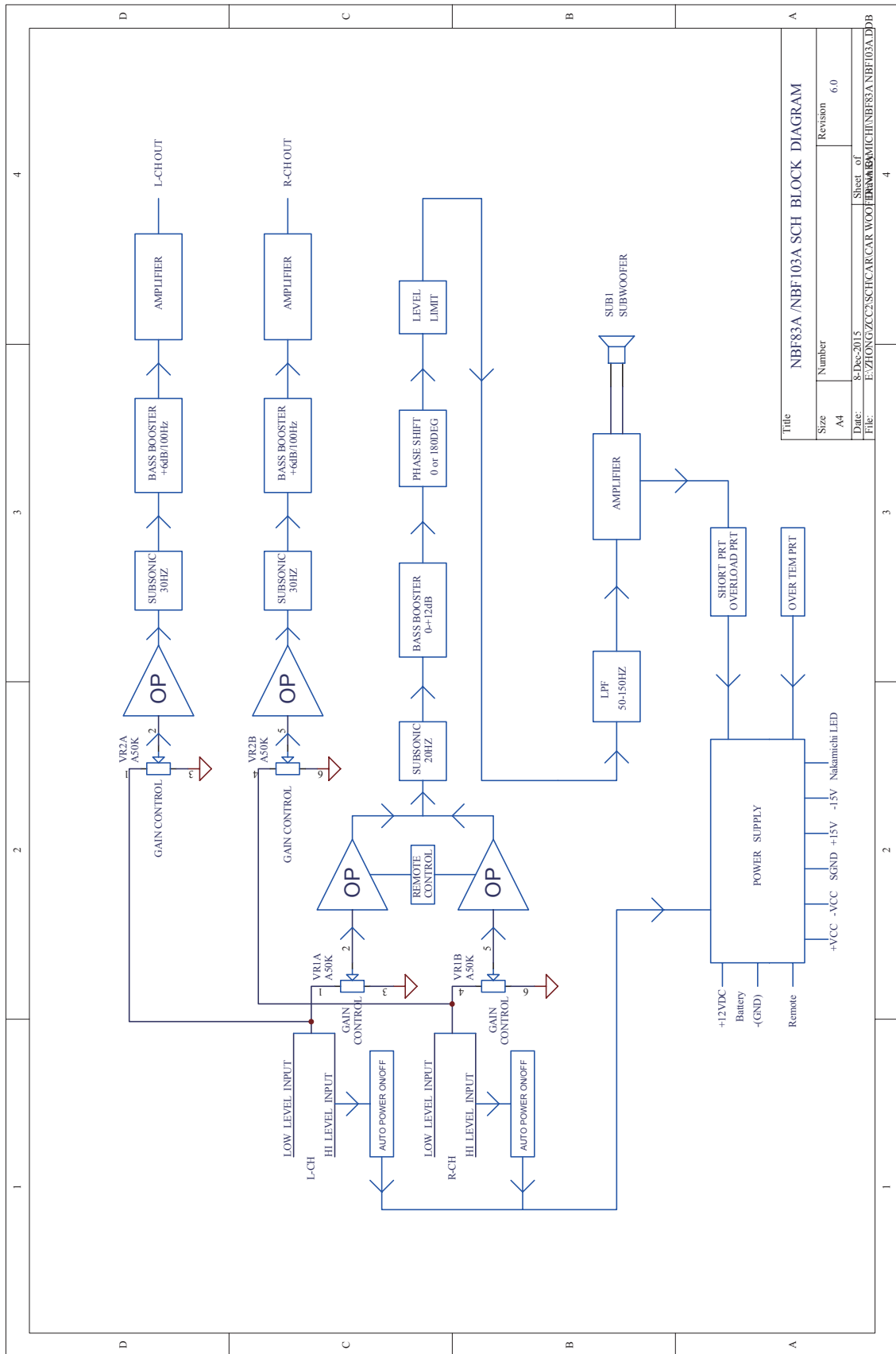

Schematic Diagram

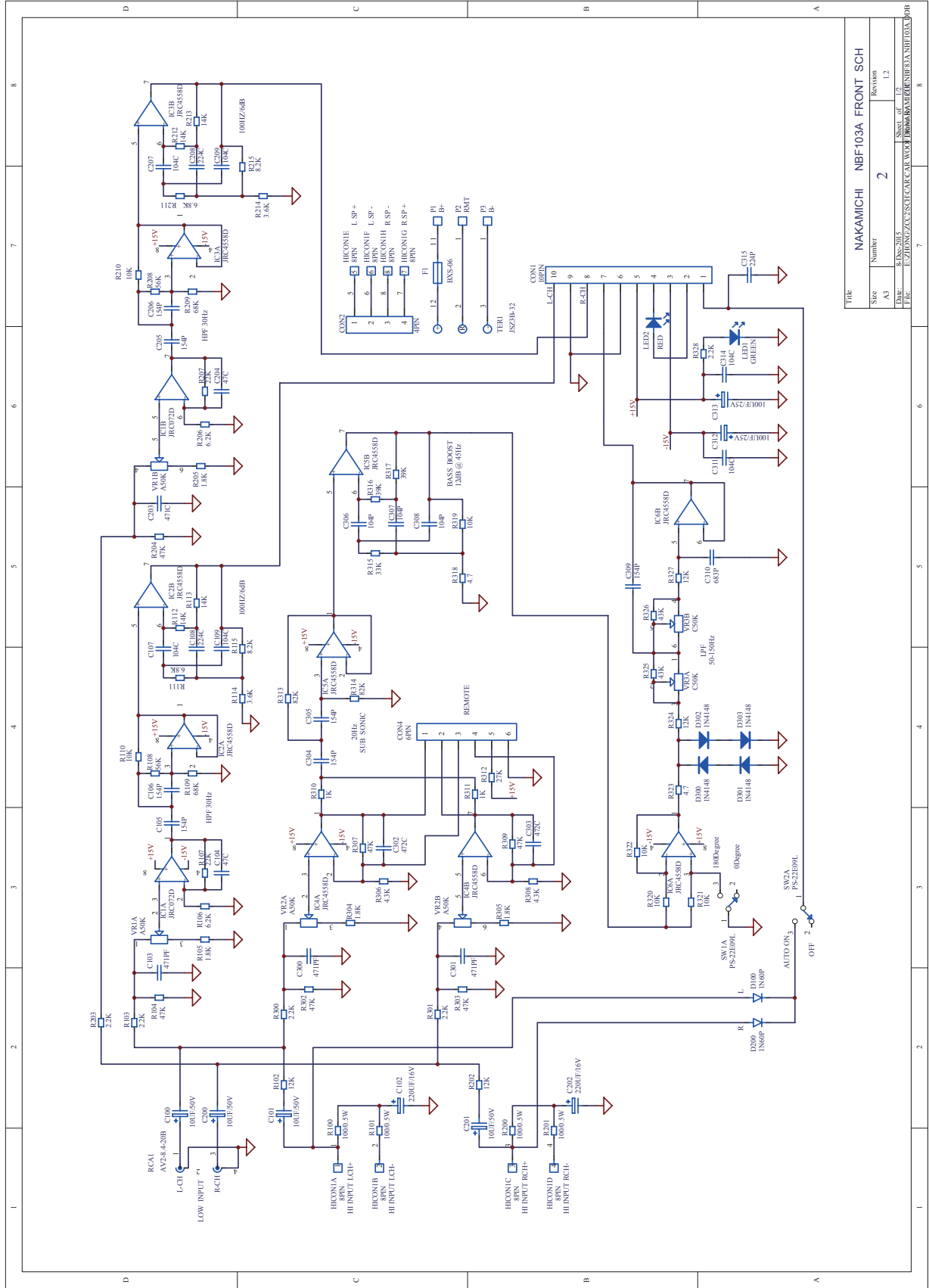

TITLE			
NAKAMICHI NBF-103A FRONT SCH			
Size	Number	Revision	
A3	2	1.2	
Date	3/15/2015	Sheet of	12
File: E:\ZUNOUG\ZUNOUG\CAD\CAR WORK\PRJ\NAKAMICHI\NBF103A.D09			

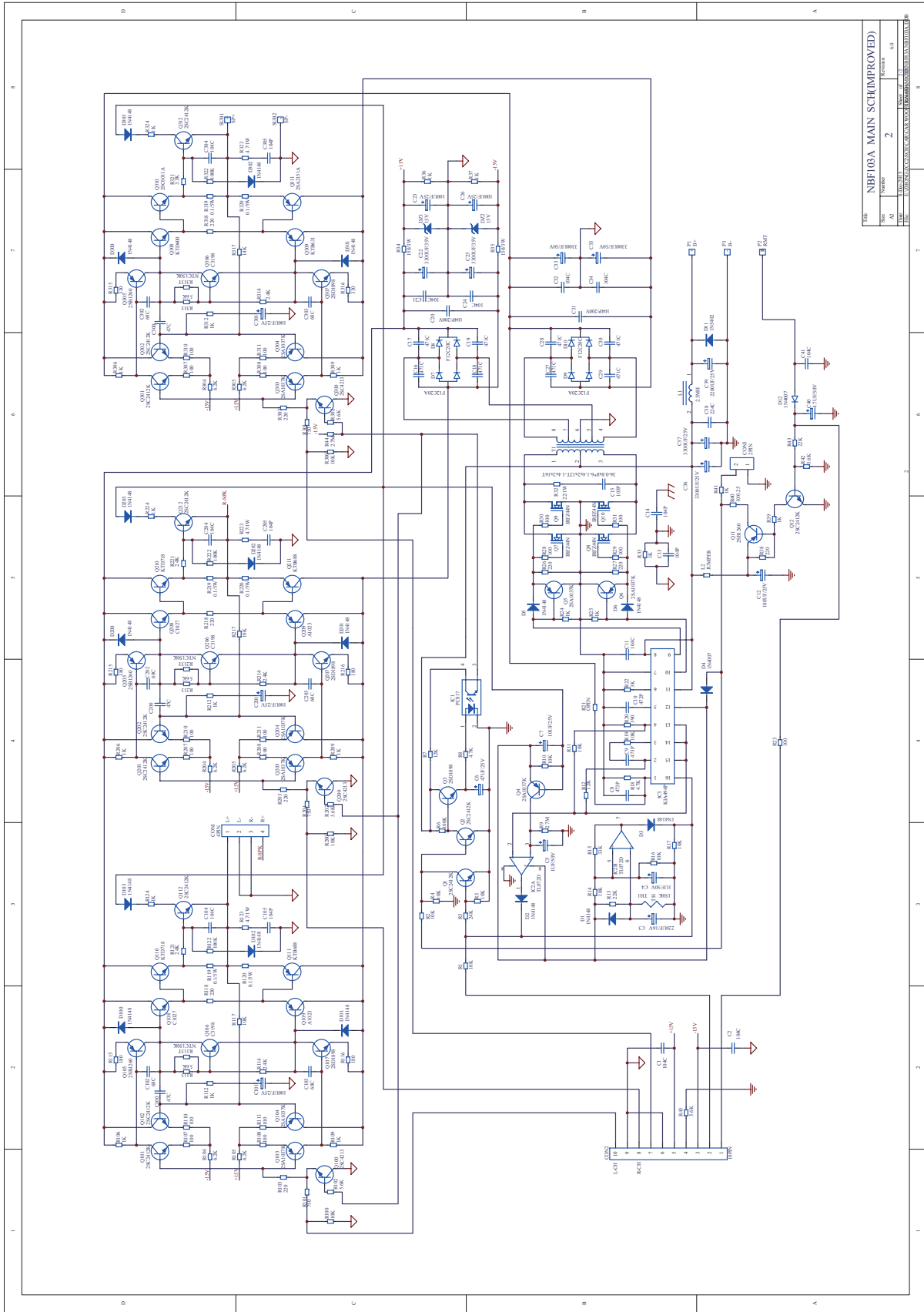

Doc	NBF103A MAIN SCH(IMPROVED)		
Rev	Number	2	Revision
Rev	1	1	0.0
Doc	P:\2005\103A\103A MAIN SCH (IMPROVED)\NBF103A MAIN SCH.DWG		

Control PCB Bottom Layer

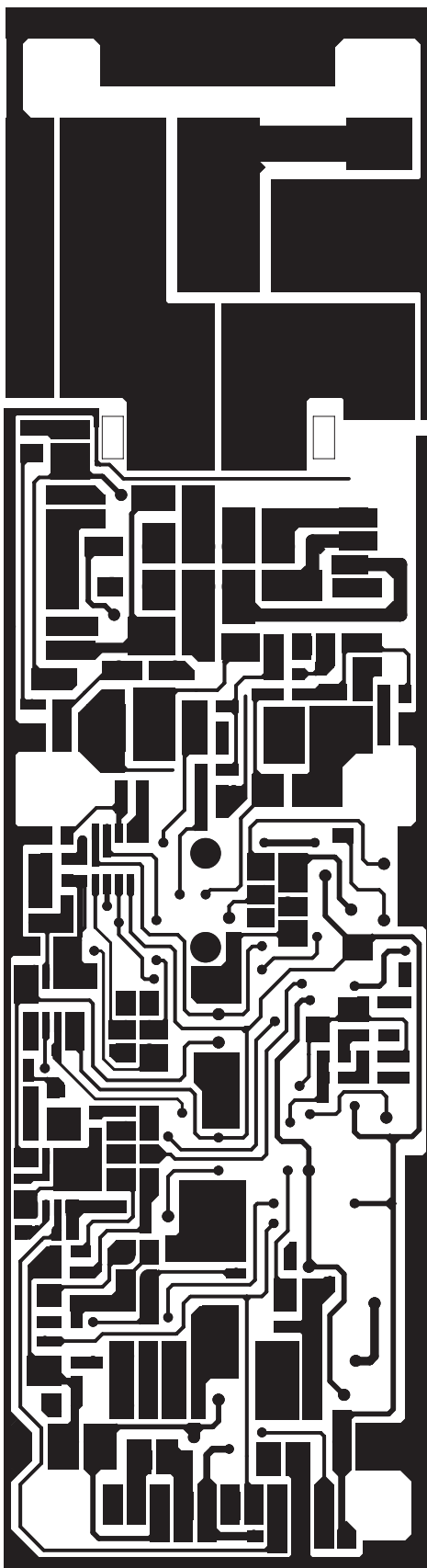

Control PCB TOP Layer

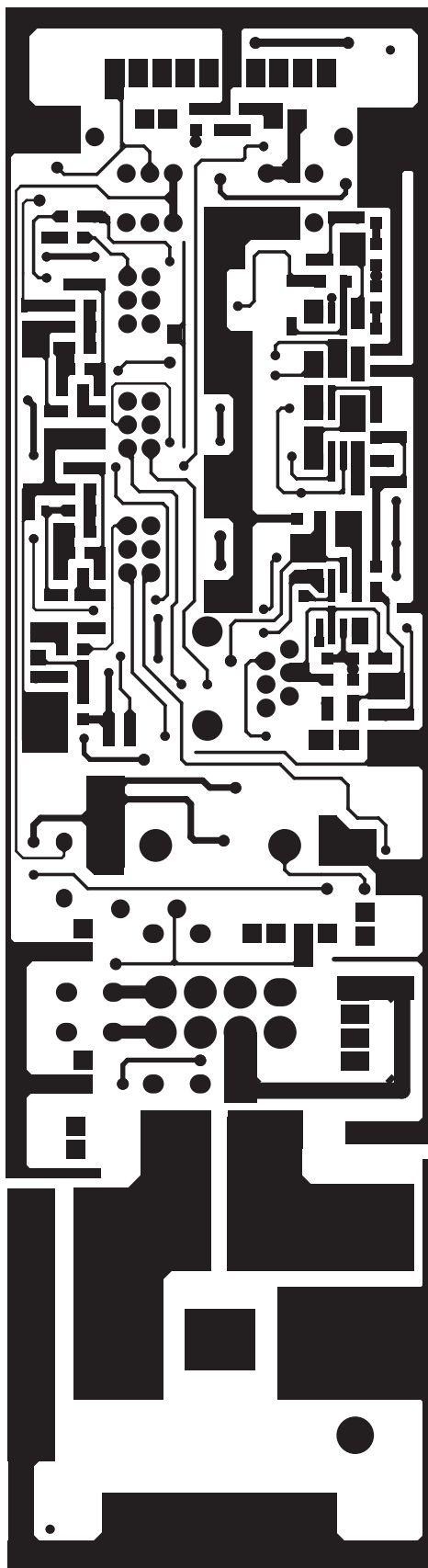

Control PCB Bottom Silk

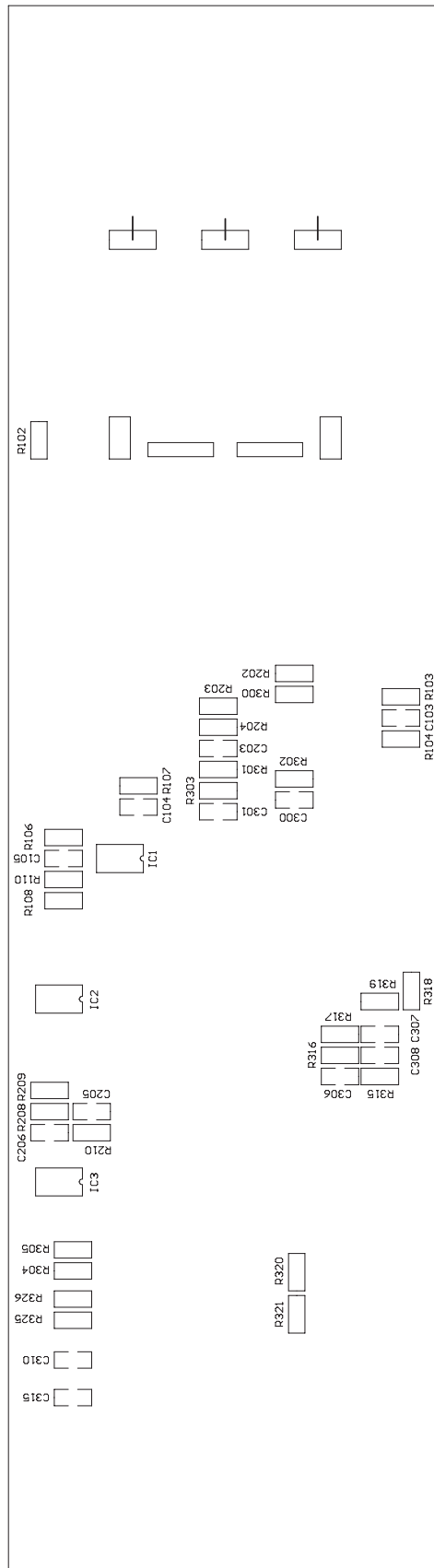

Power PCB Bottom Layer

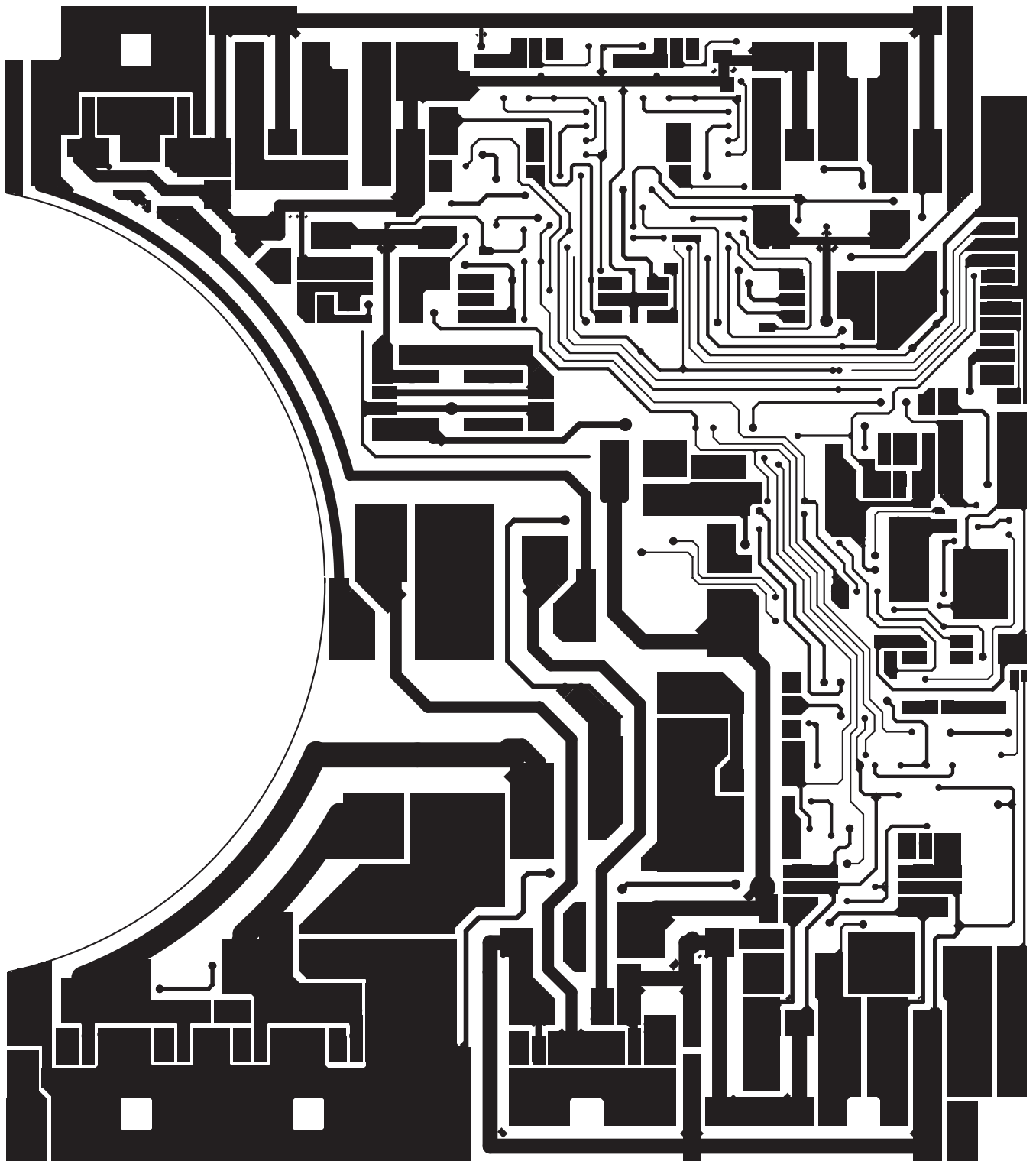

Power PCB Top Layer

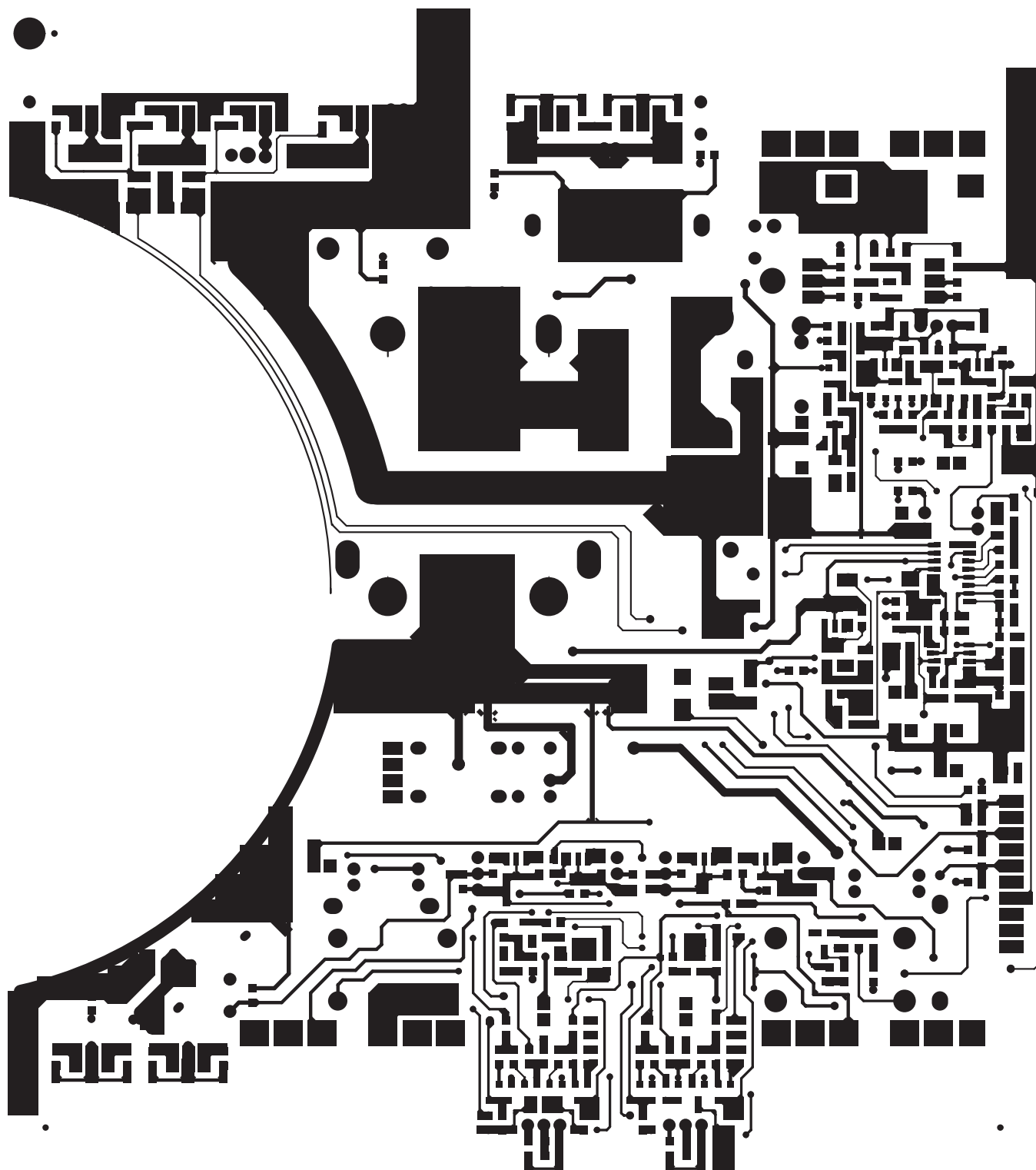

Power PCB Top Silk

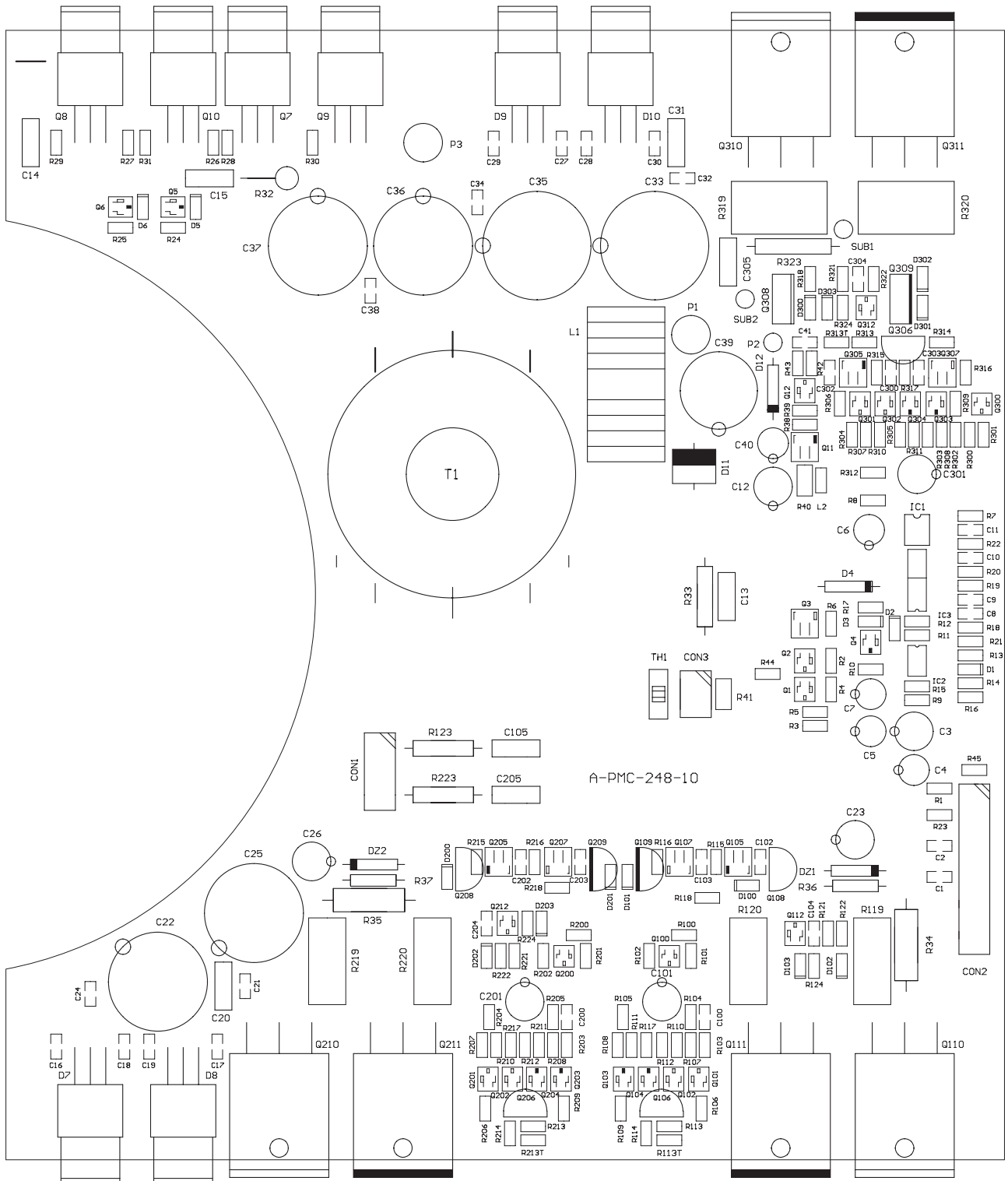

Packaging exploded Drawing

NBF103A Packaging exploded Drawing

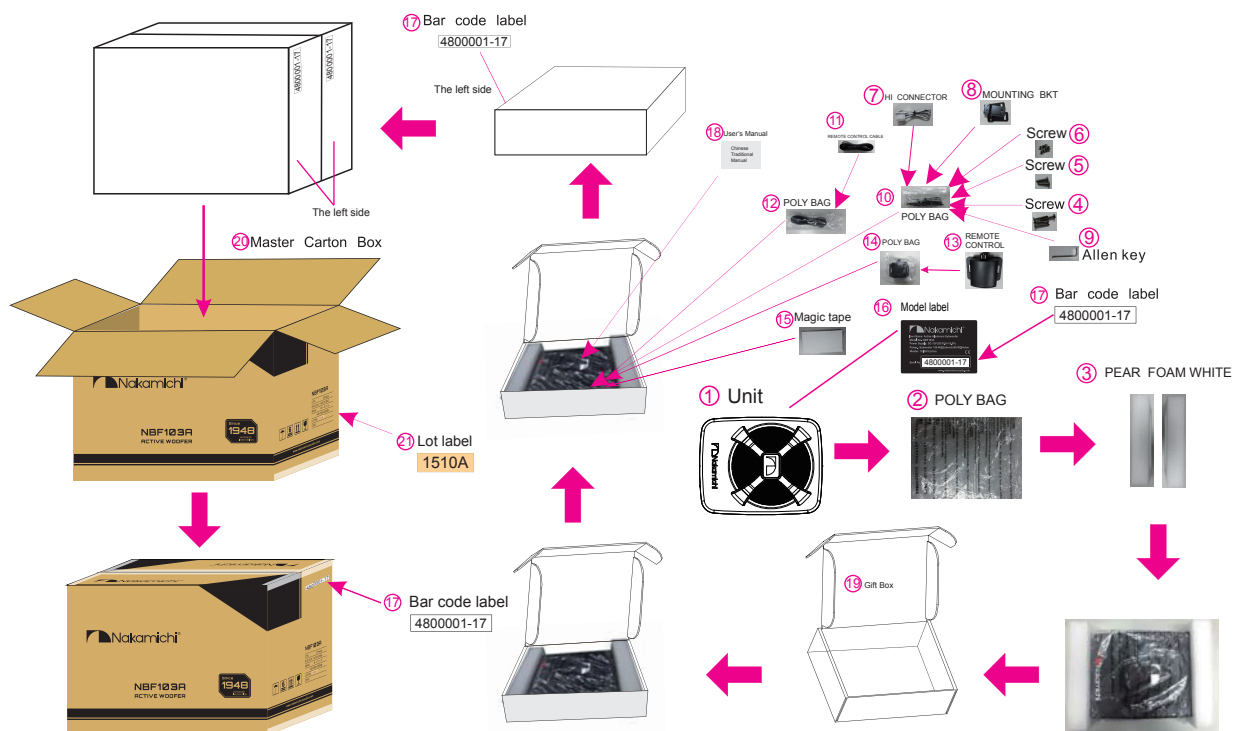

NO.	Part No	Part Name	QTY	REMARK	NO.	Part No	Part Name	QTY	REMARK
①	NBF103A	Unit	1		⑫	A-YOVB-10013005	Poly bag	1	
②	A-YOVB-37053005	Poly bag	1		⑬	REMOTE2N	Remote control	1	
③	A-YPSB-0048-02	Pear foam	2		⑭	A-YOVB-16025006	Poly bag	1	
④	XHTA-04+25CB	SCREW	4		⑮	MGT1200002	Magic tape	1	
⑤	XHBT-03+14CB	SCREW	2		⑯	A-MLNK-NBF103A-01	Model label	1	
⑥	XHBM-04+06CB	SCREW	8		⑰	A-SLNK-NBF103A-02	Bar code label	3	
⑦	A-HMHB6-017A	HI CONNECTOR	1		⑱	A-IMNK-NBF103A-03	Manual	2	
⑧	A-APBK-0054-01B	MOUNTING BKT	1		⑲	A-WBNK-NBF103A-02	Gift Box	1	
⑨	XHWT-03CN	ALLEN key	1		⑳	A-CTNK-NBF103A-02	Master Carton Box	1/2	
⑩	A-YOVB-16025005	Poly bag	1		㉑	A-MLNK-NBF103A-03	Lot label	2/2	
⑪	REMOTE2NW	Remote control cable	1						

Mechanical Exploded View

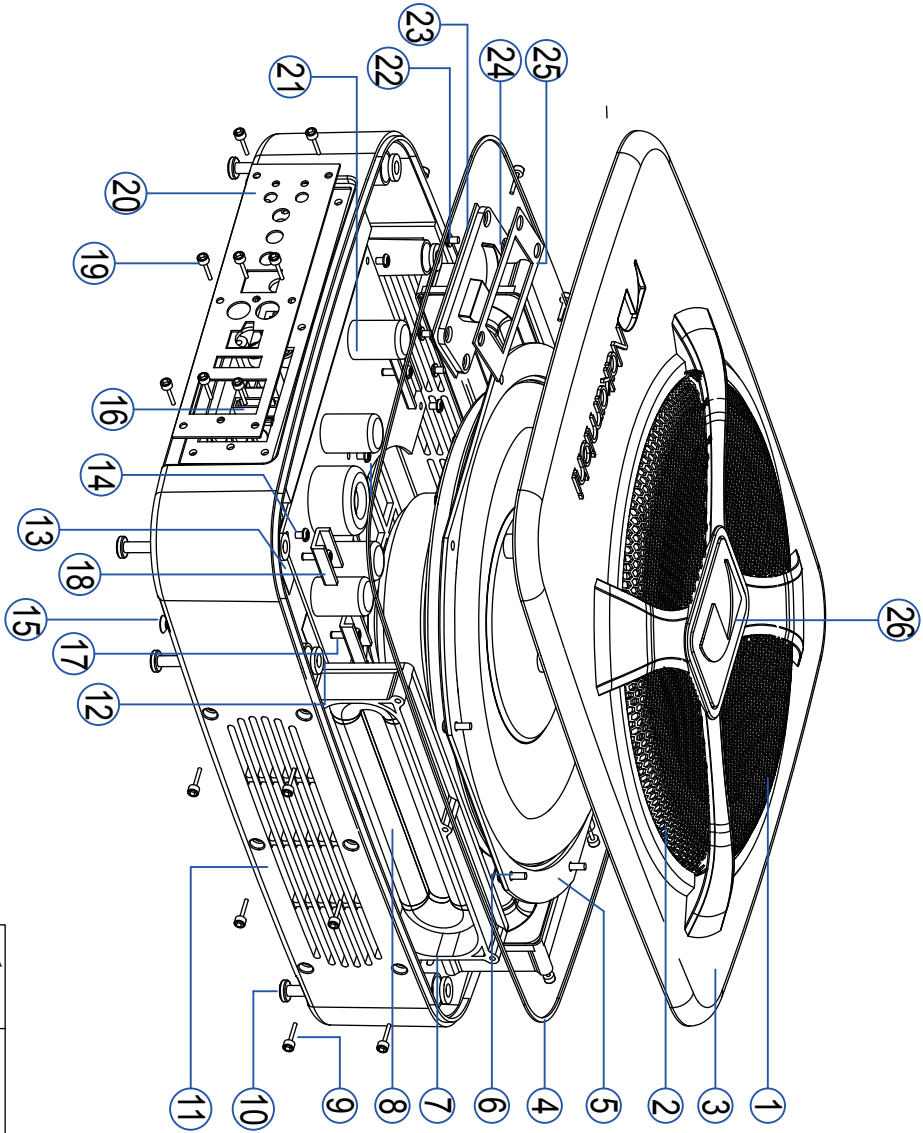

序号	料号	名称	用量
26	A-NPK-0069-02B	LOGO铭牌	1
25	A-APSP-0076-02	EVA	1
24	A-ABS-007-01	LED 灯罩	1
23	A-PFC-163-12	LED PCB	1
22	LS0200300021	螺丝	4
21	A-PFL-174-10	PCBA功放板	1
20	A-APPL-0319-01B	铁面板	1
19	LS0200300003	螺丝	8
18	A-APRK-0050-01N	压片	7
17	LS02003000046	螺丝	7
16	A-PMC-248-10	PCBA控制电路板	1
15	LS0200200020	螺丝	1
14	LS0200100024	螺丝	5
13	J00200100003	云母片	2
12	TZ0200100001	铜柱	5
11	A-APHS-0307-01B	铸铝底座	1
10	LS0200300022	螺丝	6
9	LS0200400008	螺丝	18
8	A-APSB-0032-01	橡胶垫	1
7	LB000200002	假喇叭	3
6	LS0200500021	螺丝	8
5	LB000100003	喇叭	1
4	A-APSP-0080-01	EVA密封条	1
3	A-APHS-0306-01B	铸铝上盖	1
2	A-APGL-10-05B	扇形铁网B	2
1	A-APGL-10-06B	扇形铁网A	2

1.	PART NO.	MATERIAL	BLACK	1	VL. 0
NO.	GRAPHICS	SCALE	FINISH	TY	VERSION
APPROVED BY	DESIGNED BY	UNIT	PART NAME	爆炸图	
		mm/m	MODEL	NBF103A	
Sound Great Industrial Limited			DATE	2015-12-10	

MARR	REVISION	RECORD	DATE	DRAWN	APPROVED