

Service
Service

Service Manual

MAIN BOARD - CIRCUIT DIAGRAM

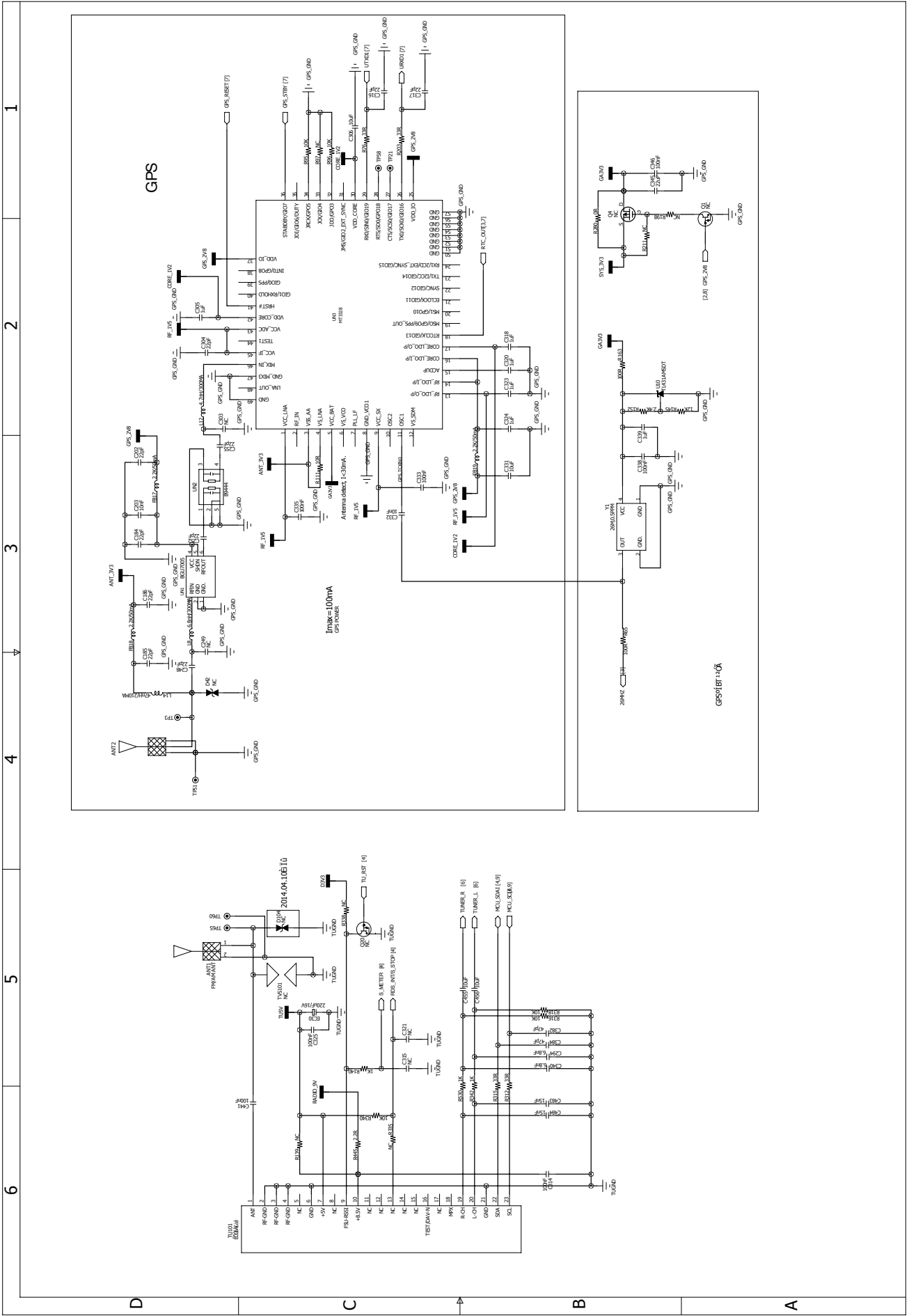

MAIN BOARD - CIRCUIT DIAGRAM

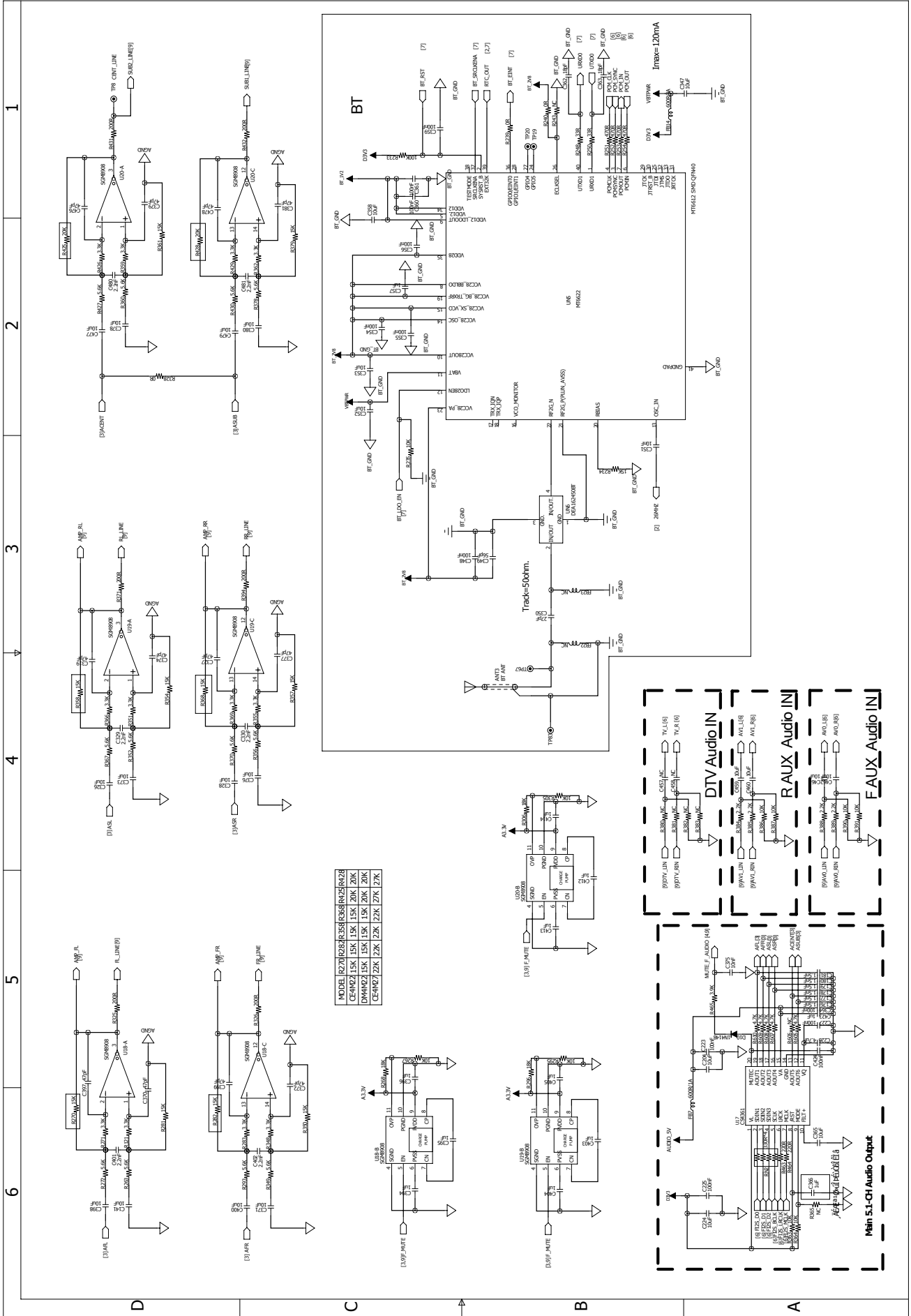

MAIN BOARD - CIRCUIT DIAGRAM

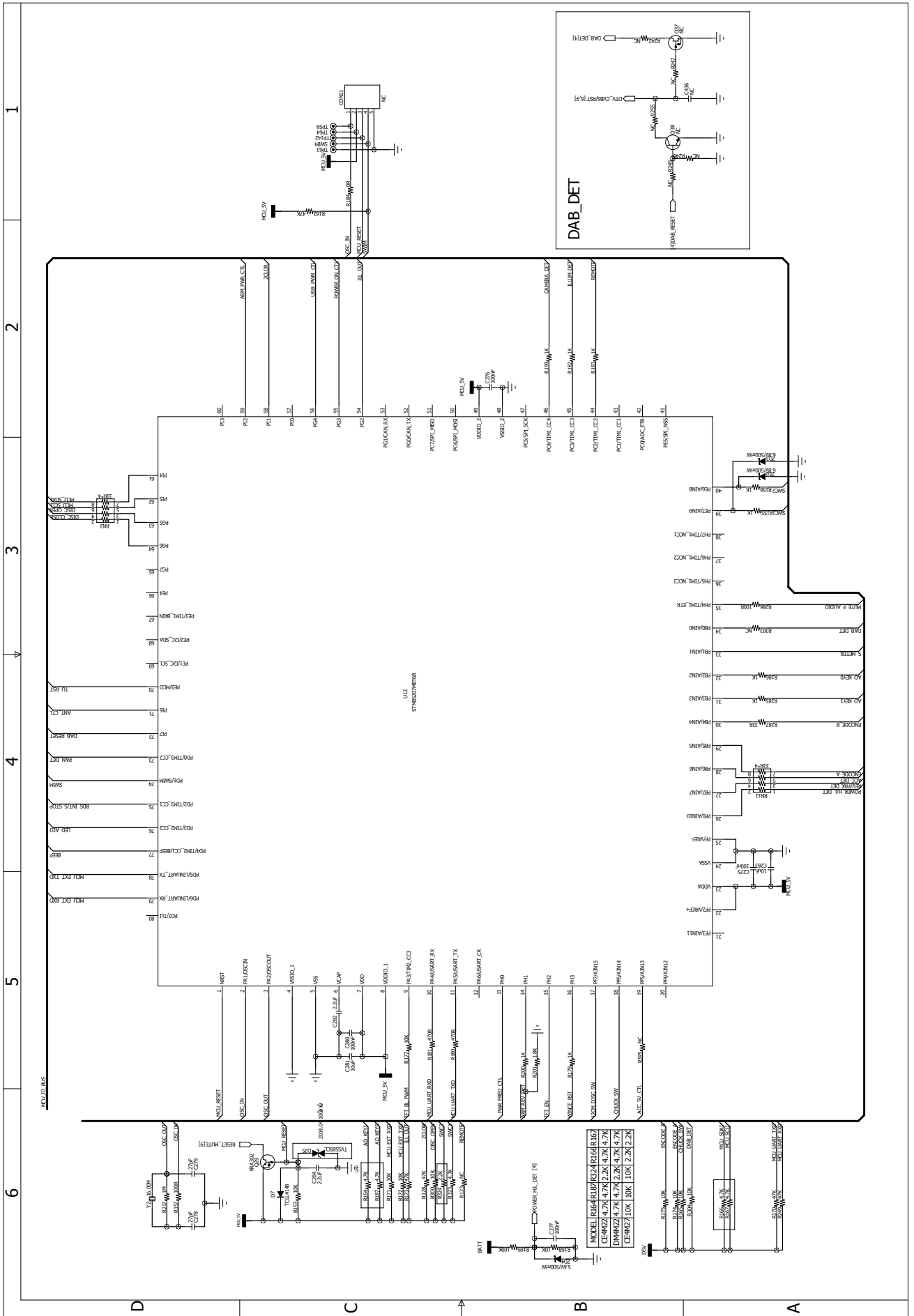

MAIN BOARD - CIRCUIT DIAGRAM

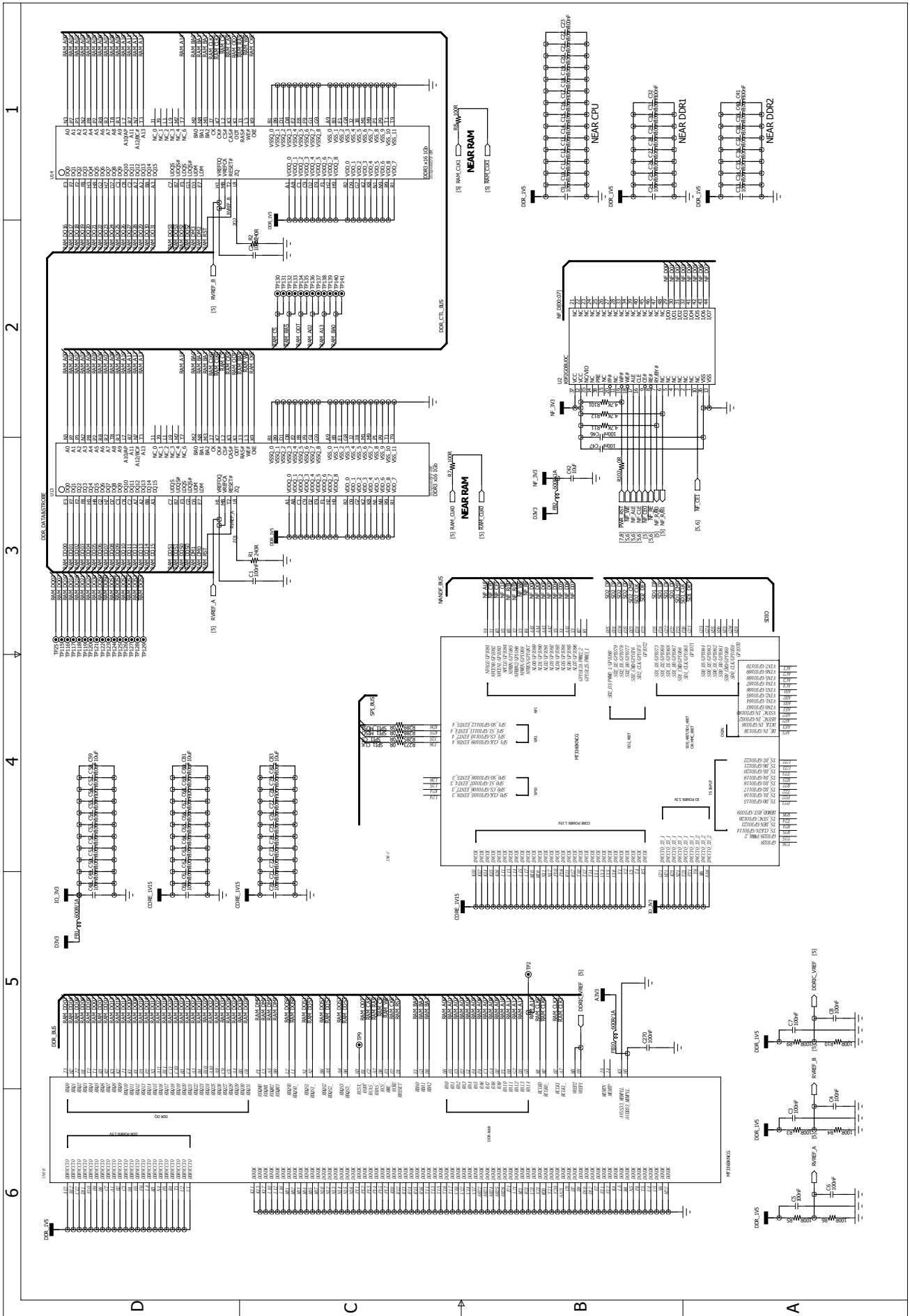

MAIN BOARD - CIRCUIT DIAGRAM

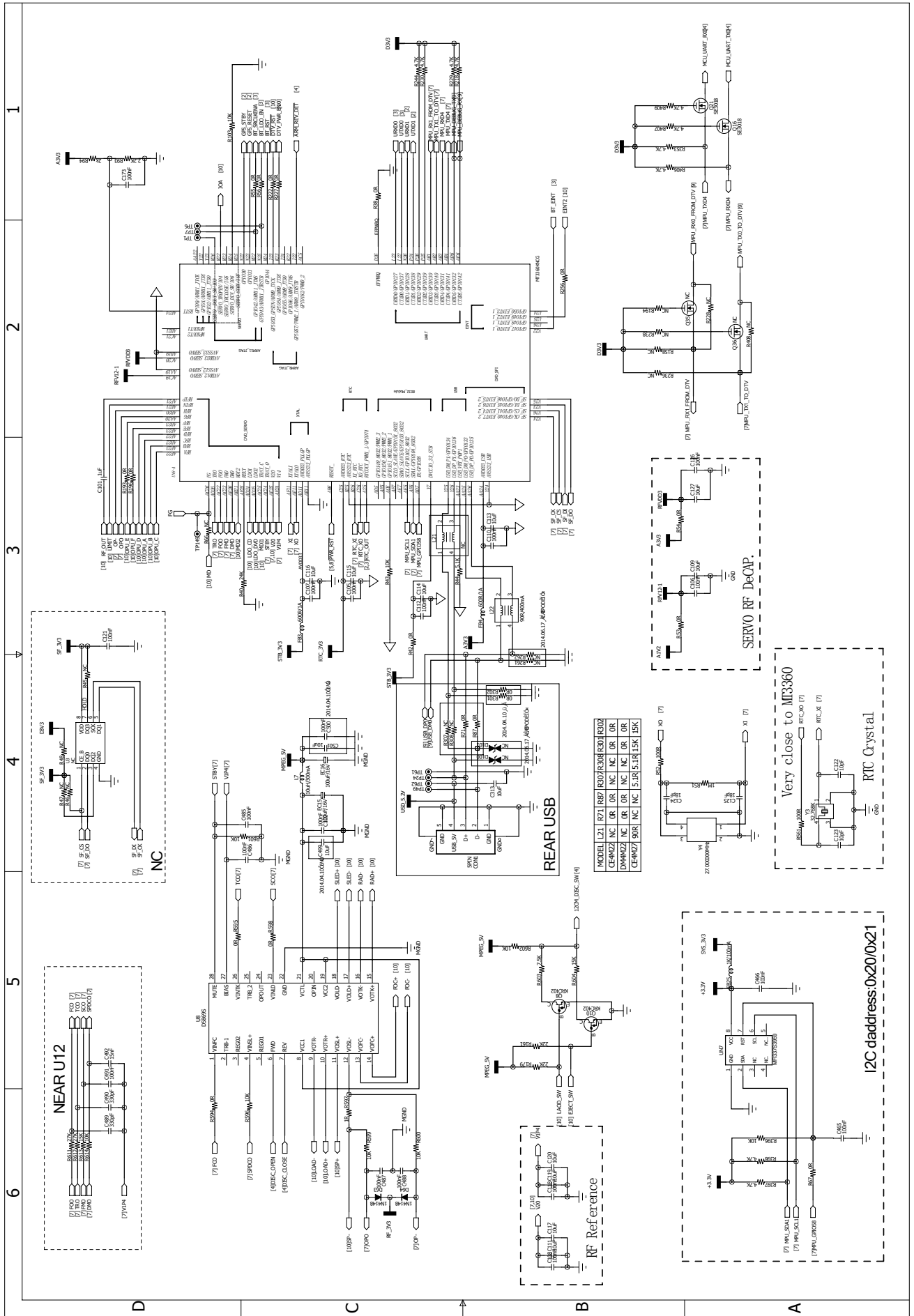

1
2
3
4
5
6

MAIN BOARD - CIRCUIT DIAGRAM

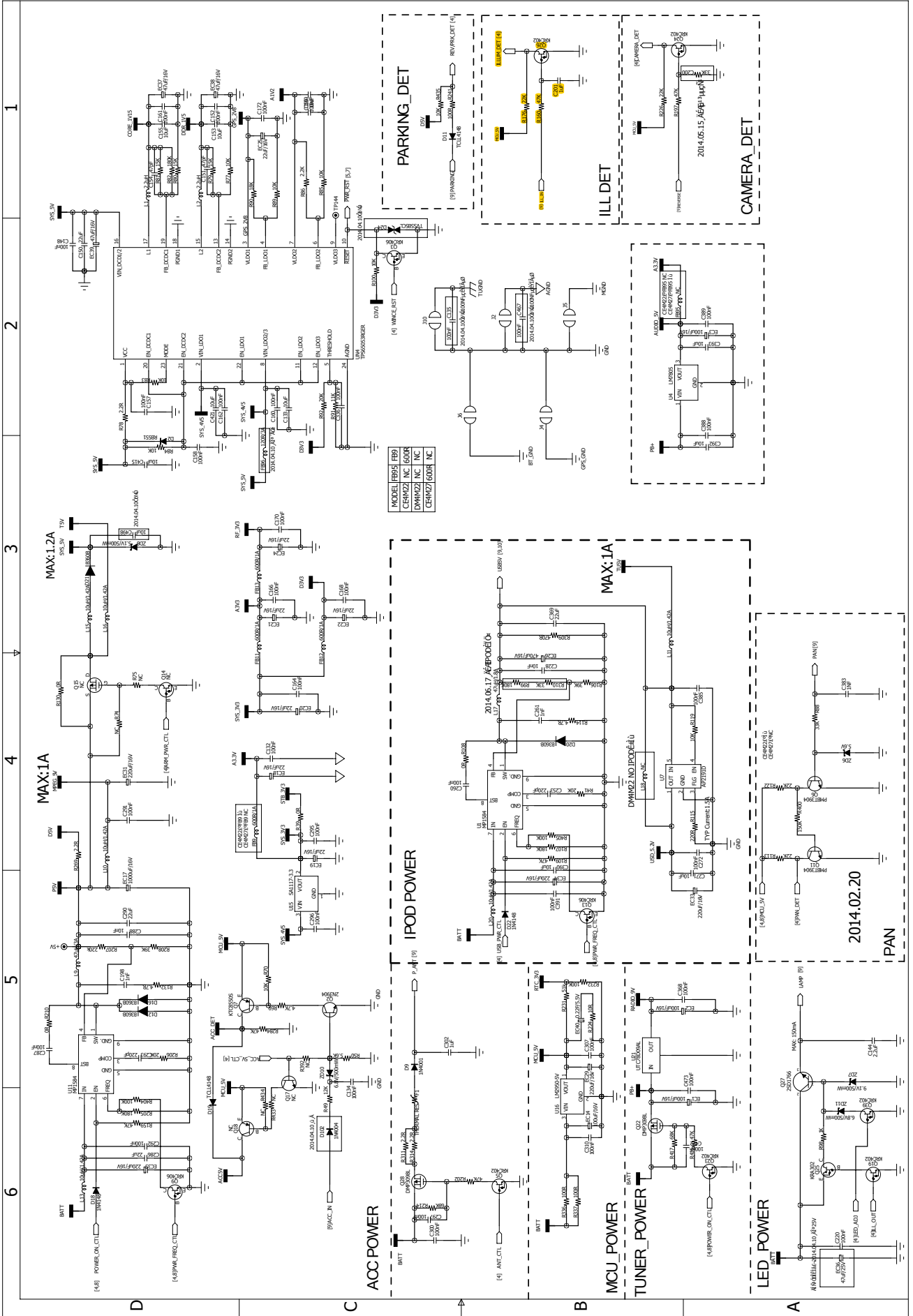

MAIN BOARD - CIRCUIT DIAGRAM

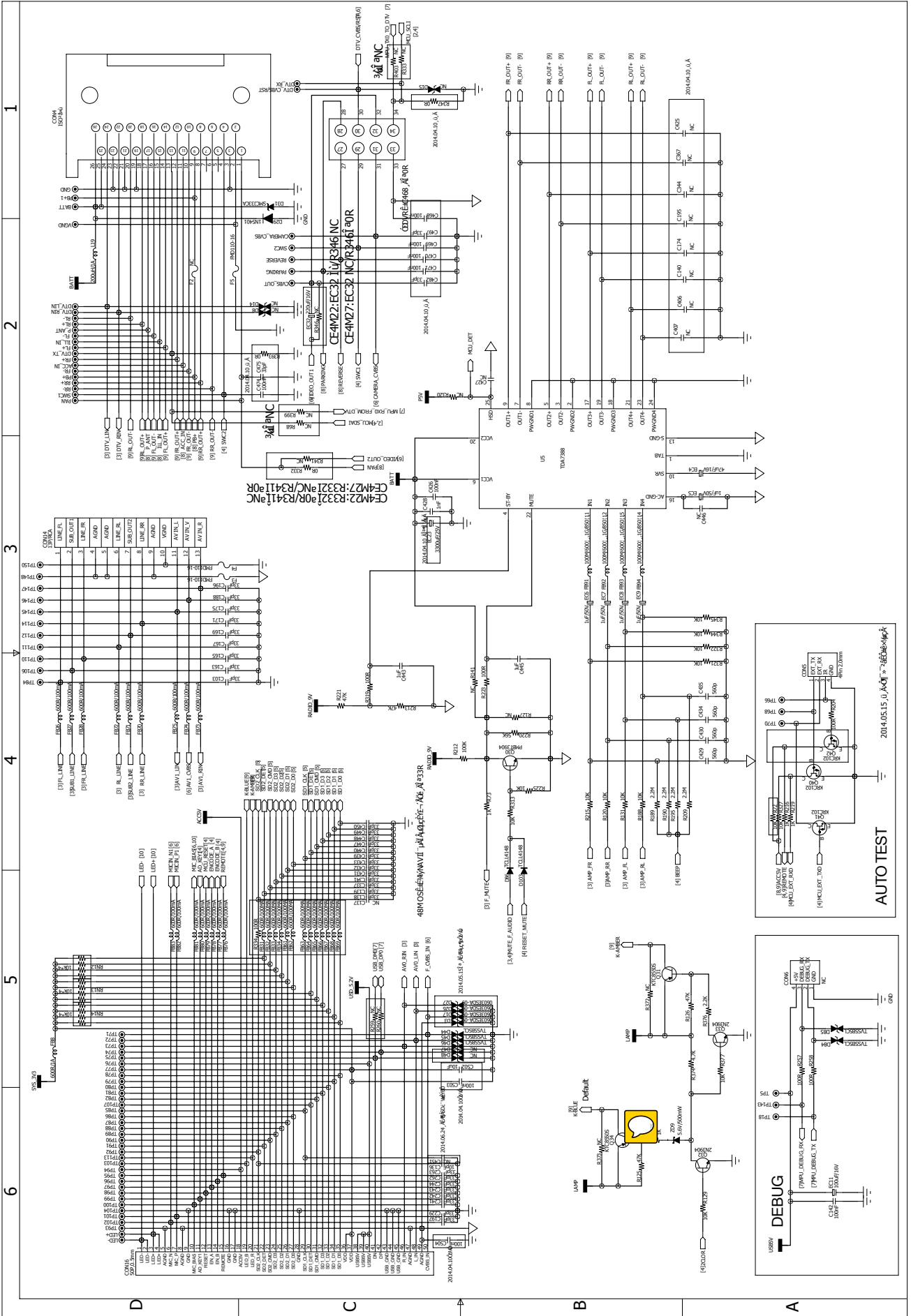

MAIN BOARD - CIRCUIT DIAGRAM

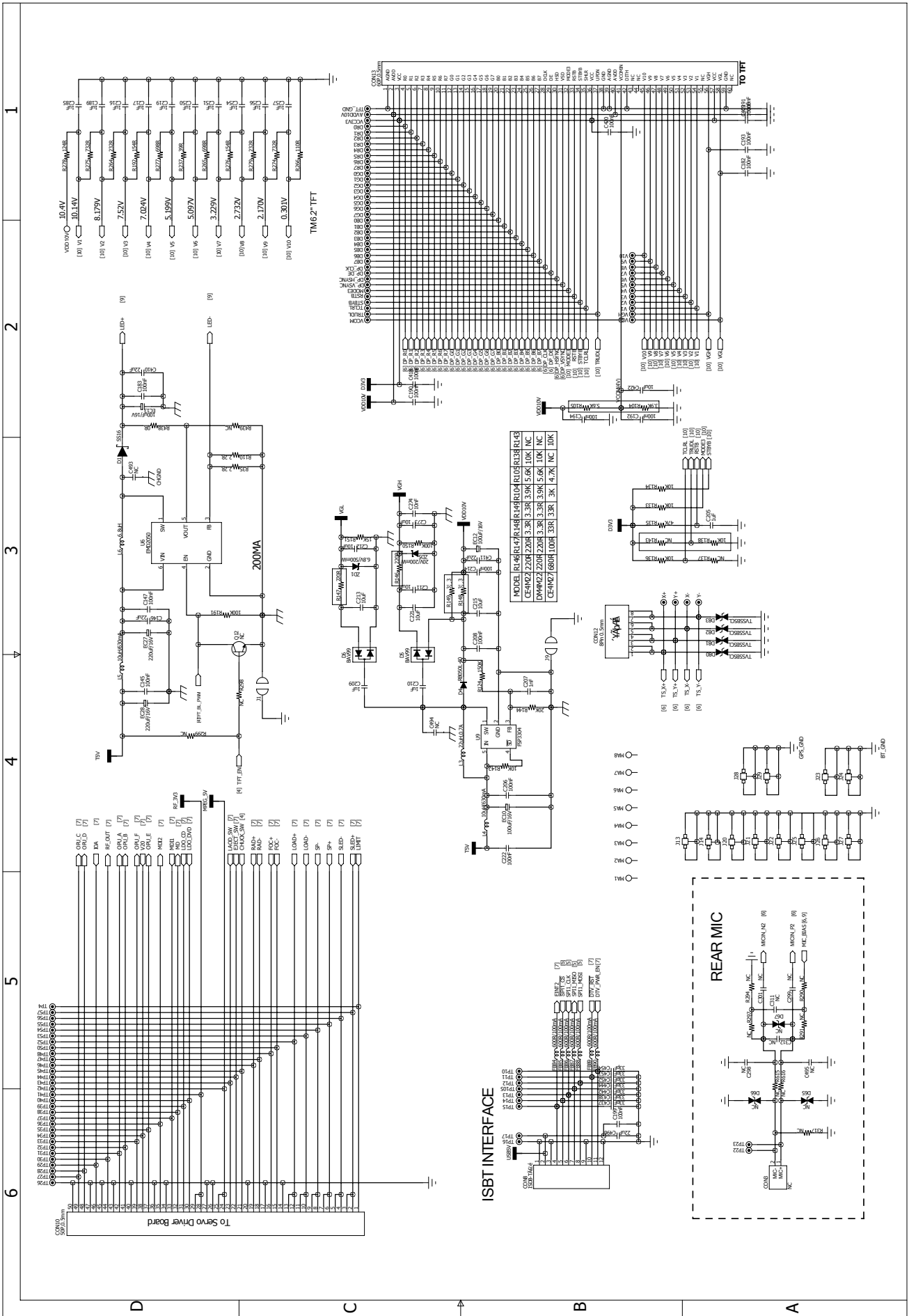

MAIN BOARD - PCB LAYOUT TOP VIEW

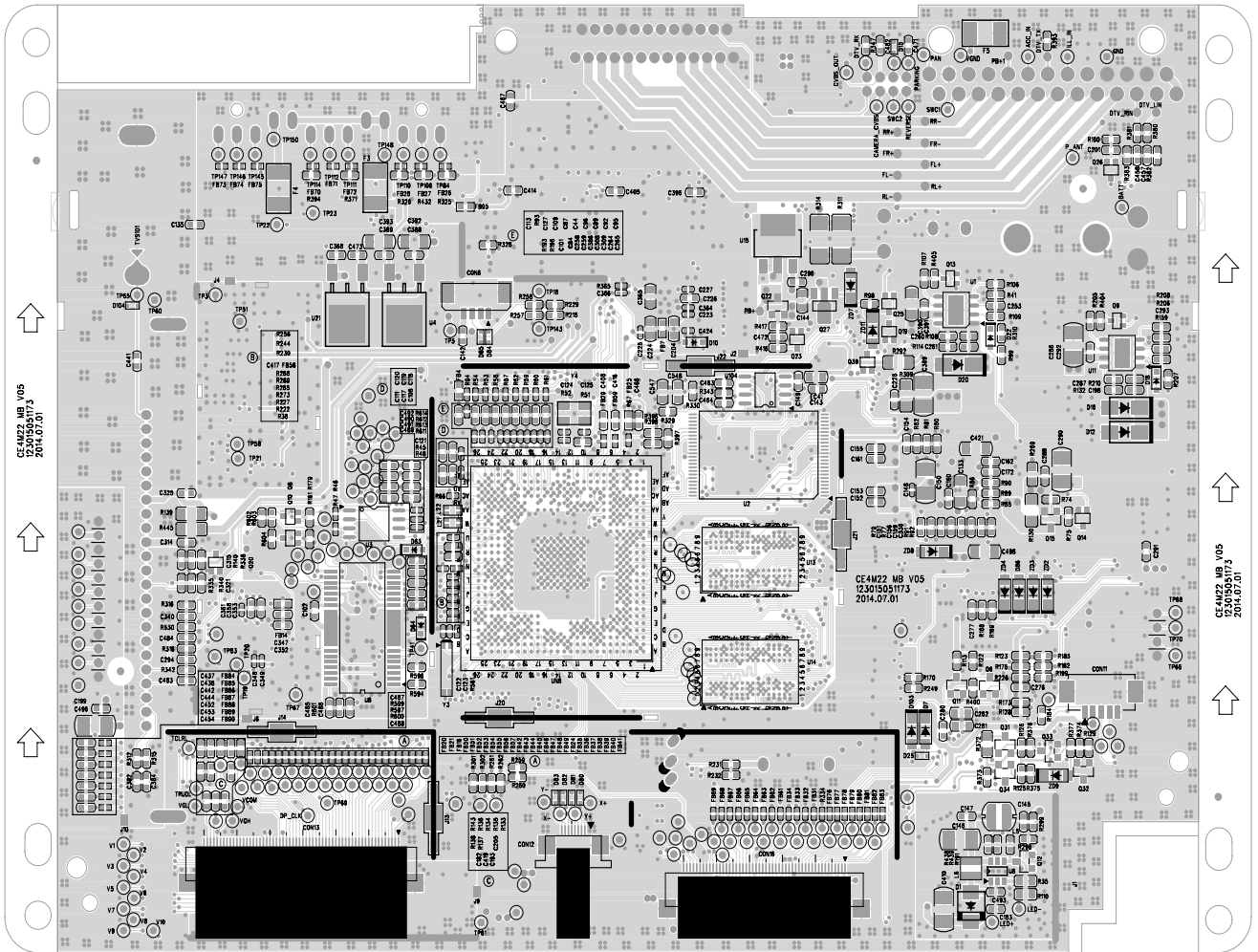

MAIN BOARD - PCB LAYOUT BOTTOM VIEW

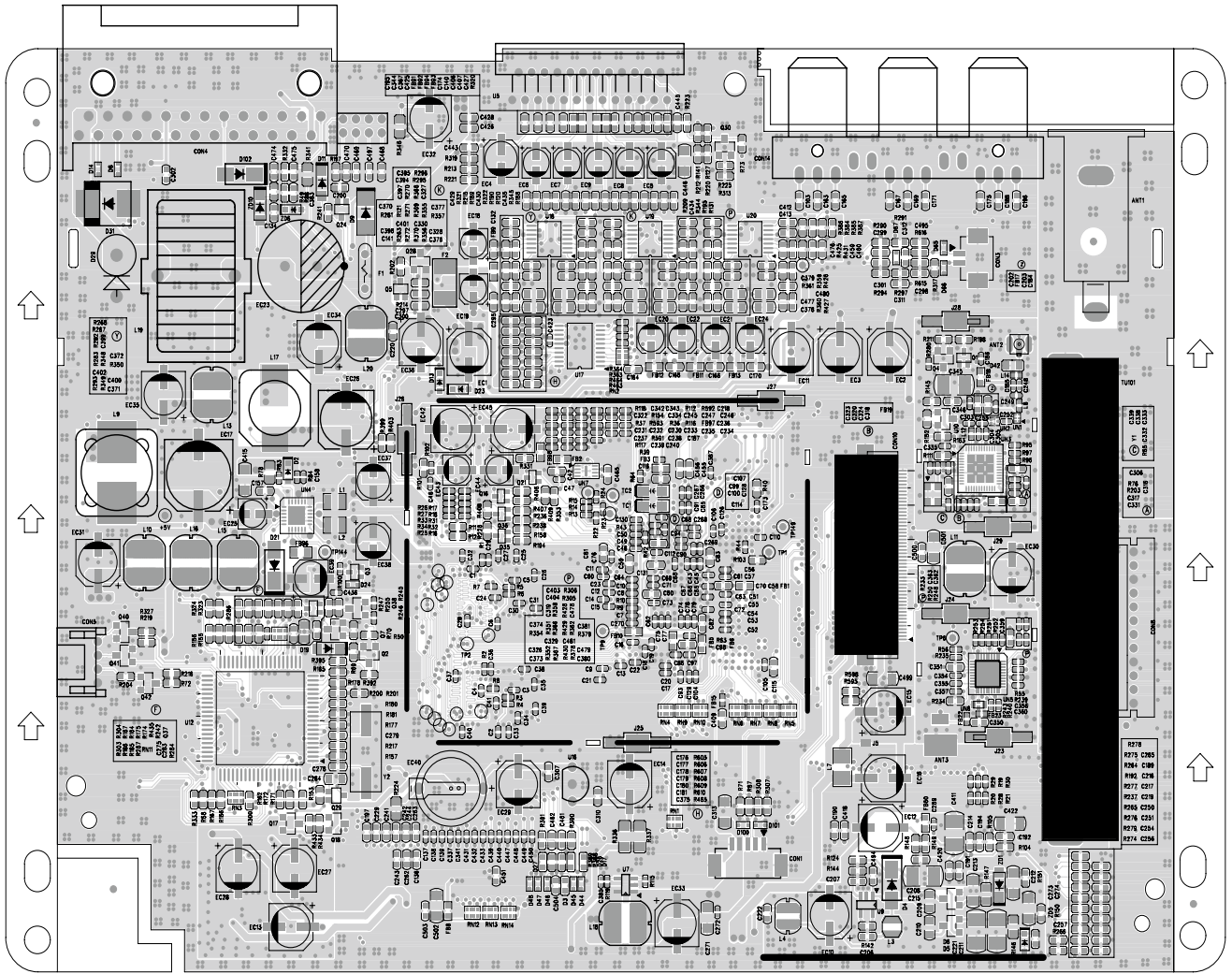

SERVO BOARD - CIRCUIT DIAGRAM

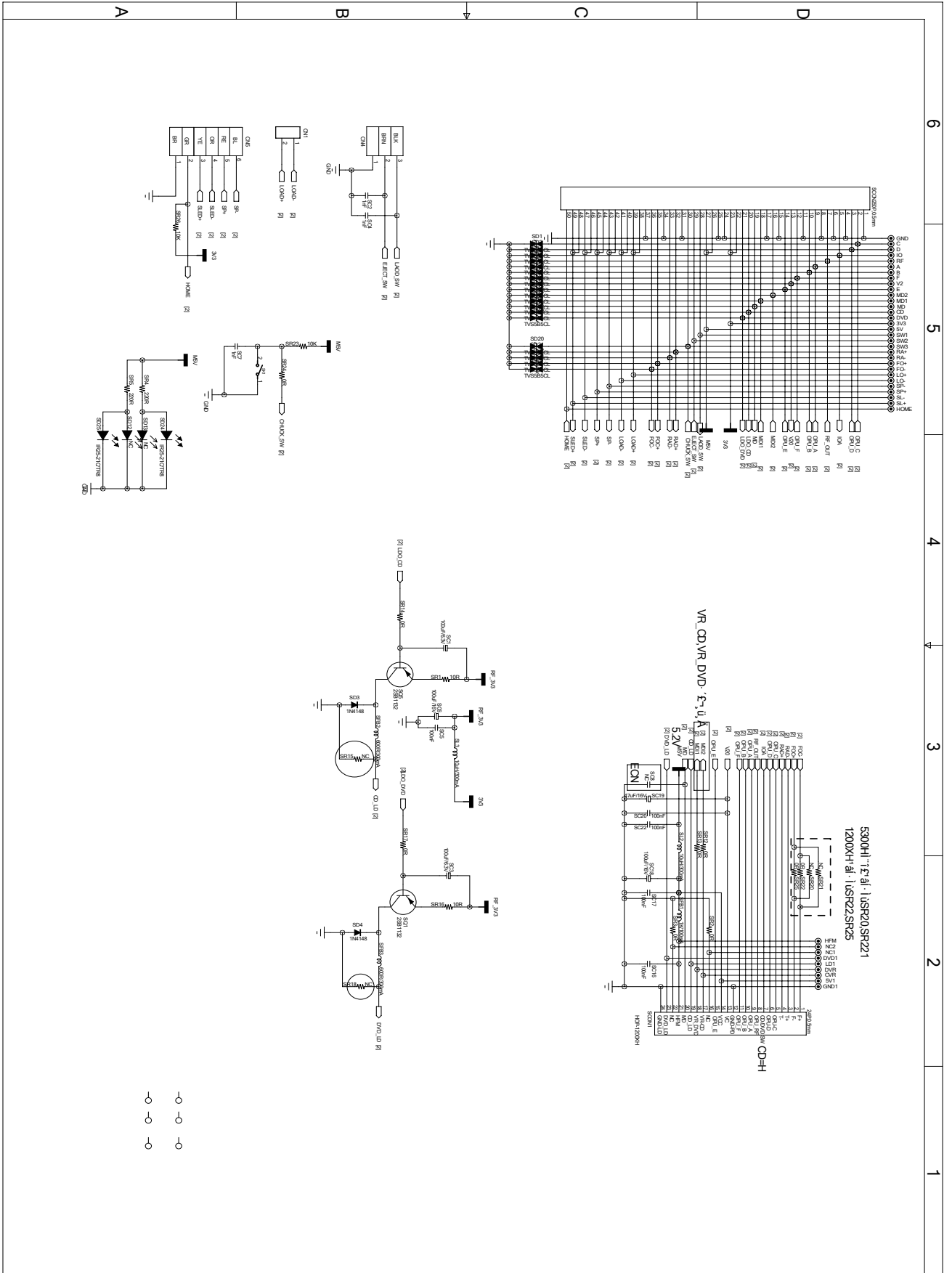

SERVO BOARD - PCB LAYOUT TOP VIEW

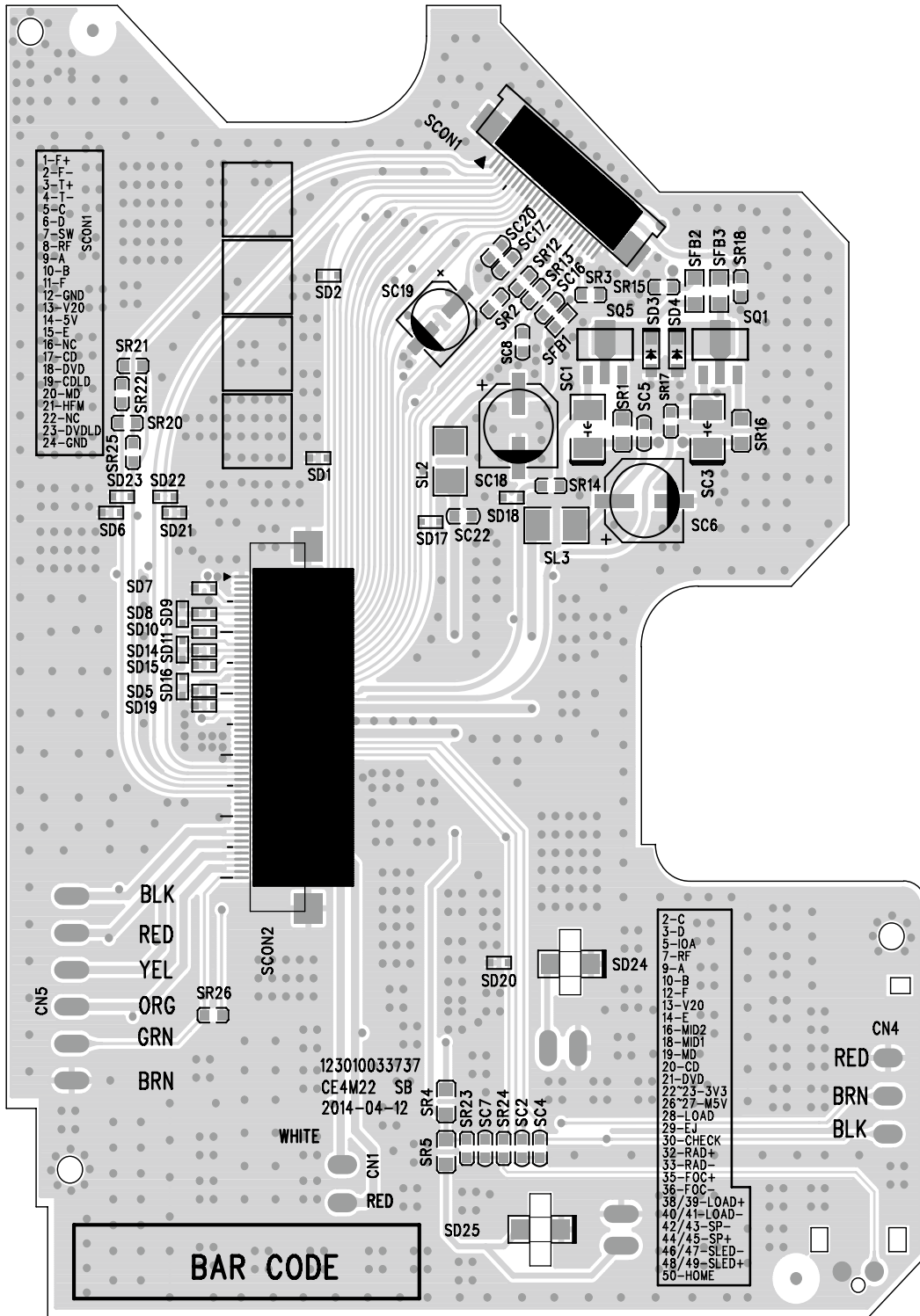

SERVO BOARD - PCB LAYOUT BOTTOM VIEW

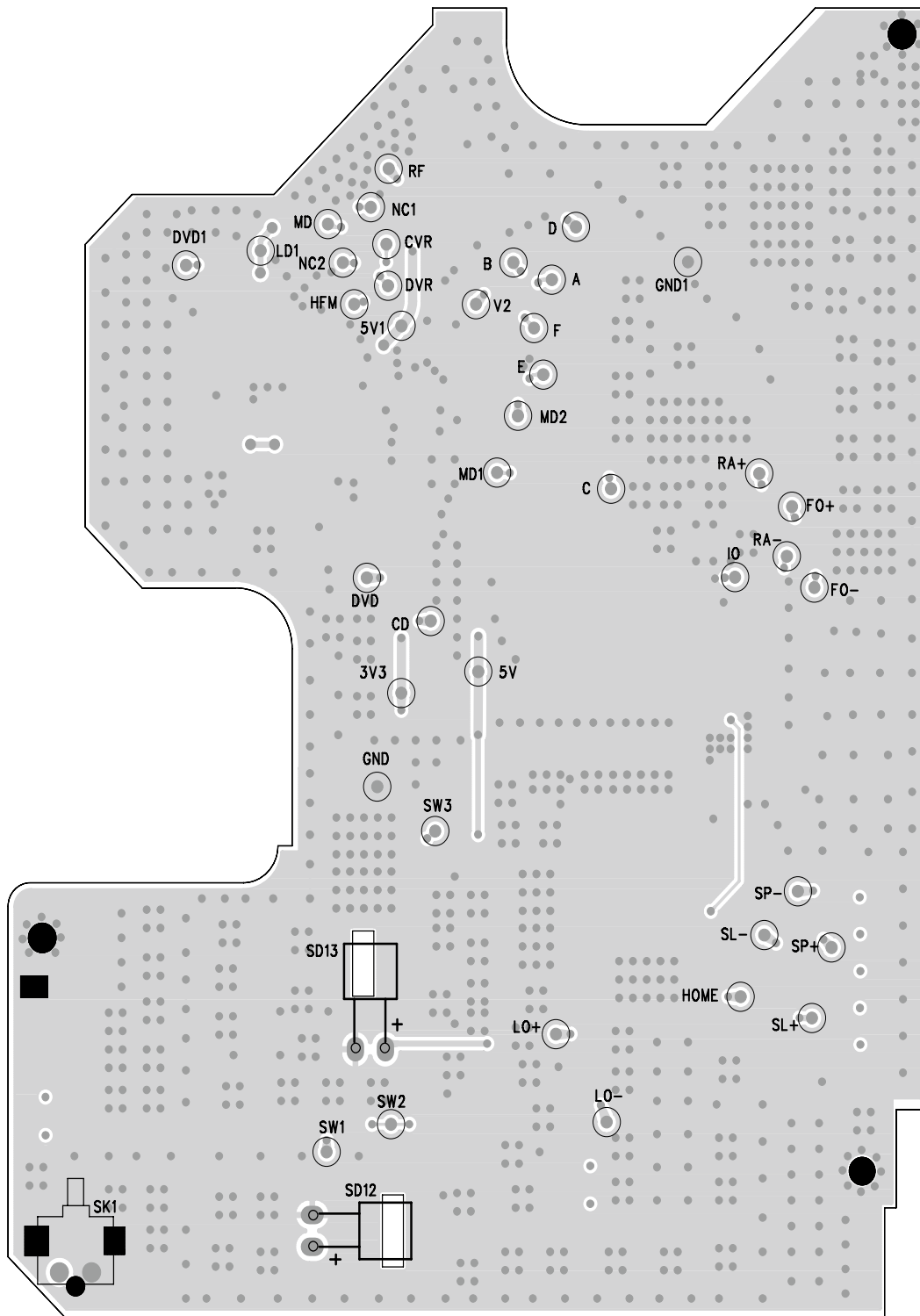

TFT BOARD - CIRCUIT DIAGRAM

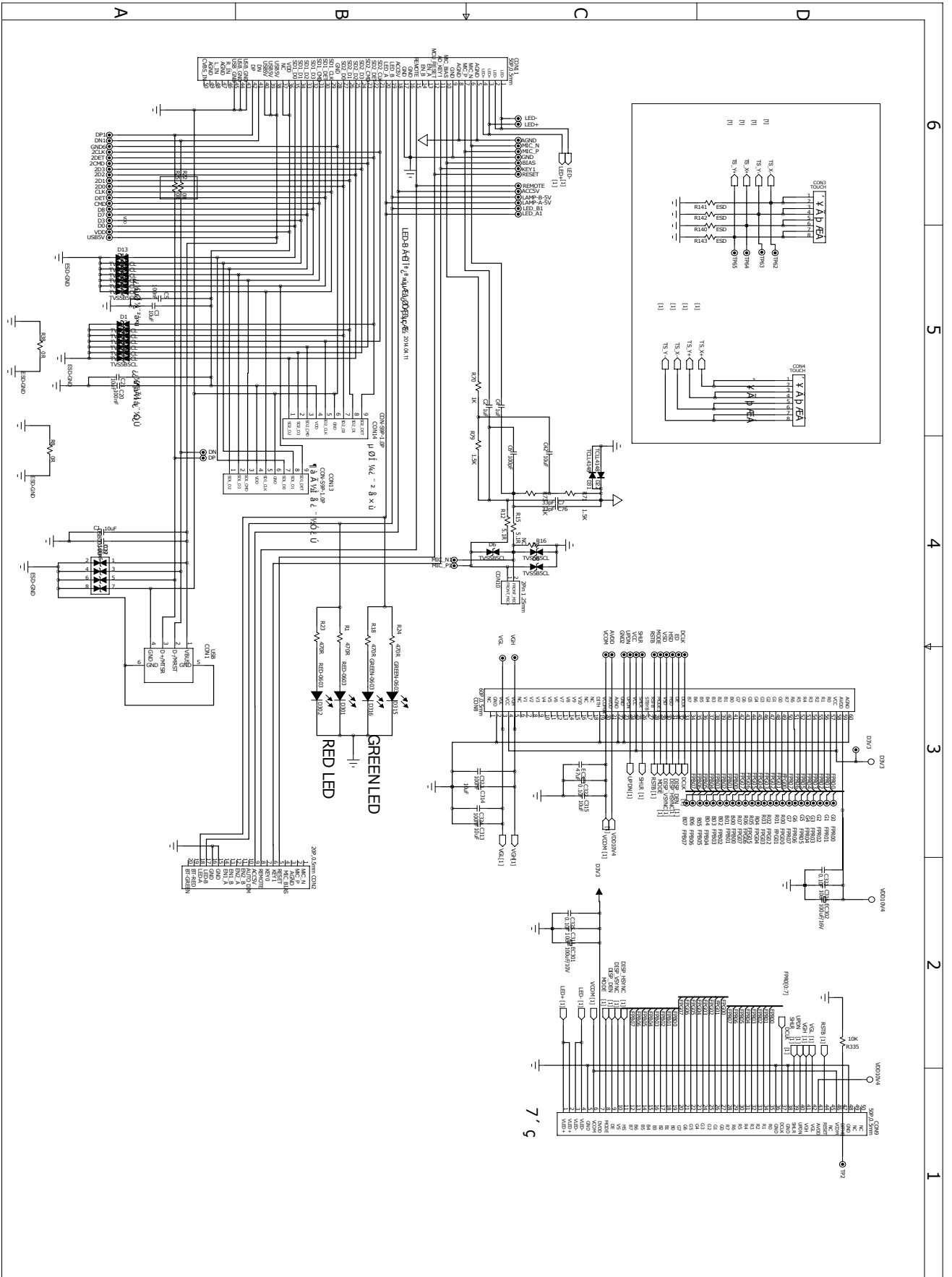

TFT BOARD - PCB LAYOUT TOP VIEW

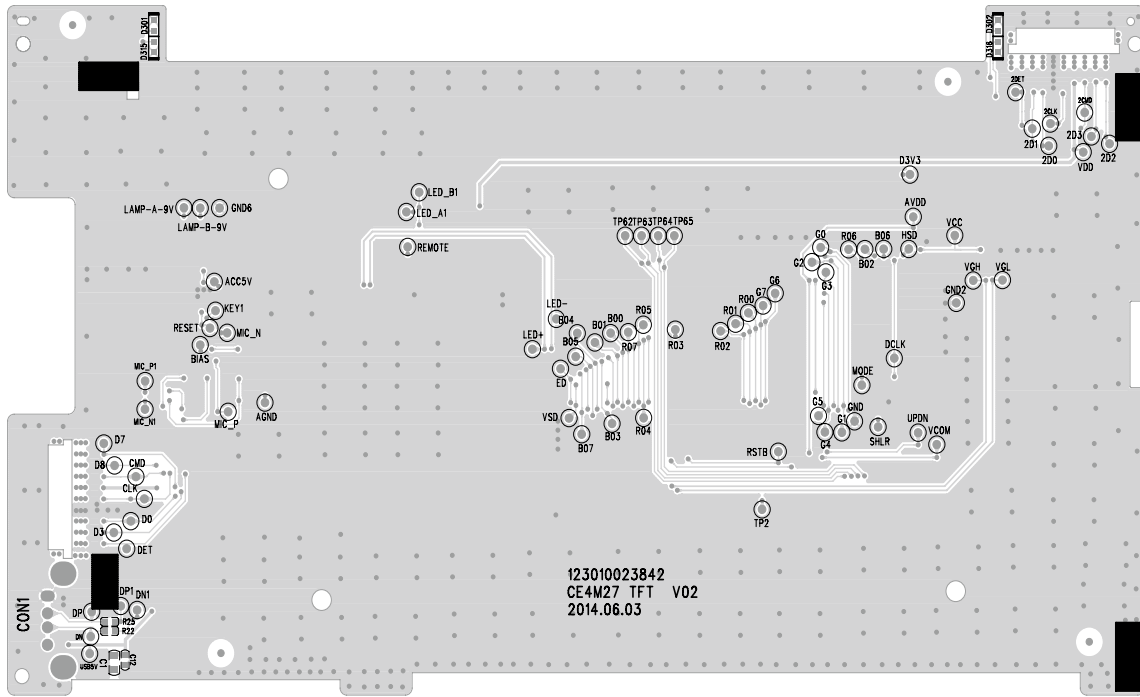

TFT BOARD - PCB LAYOUT BOTTOM VIEW

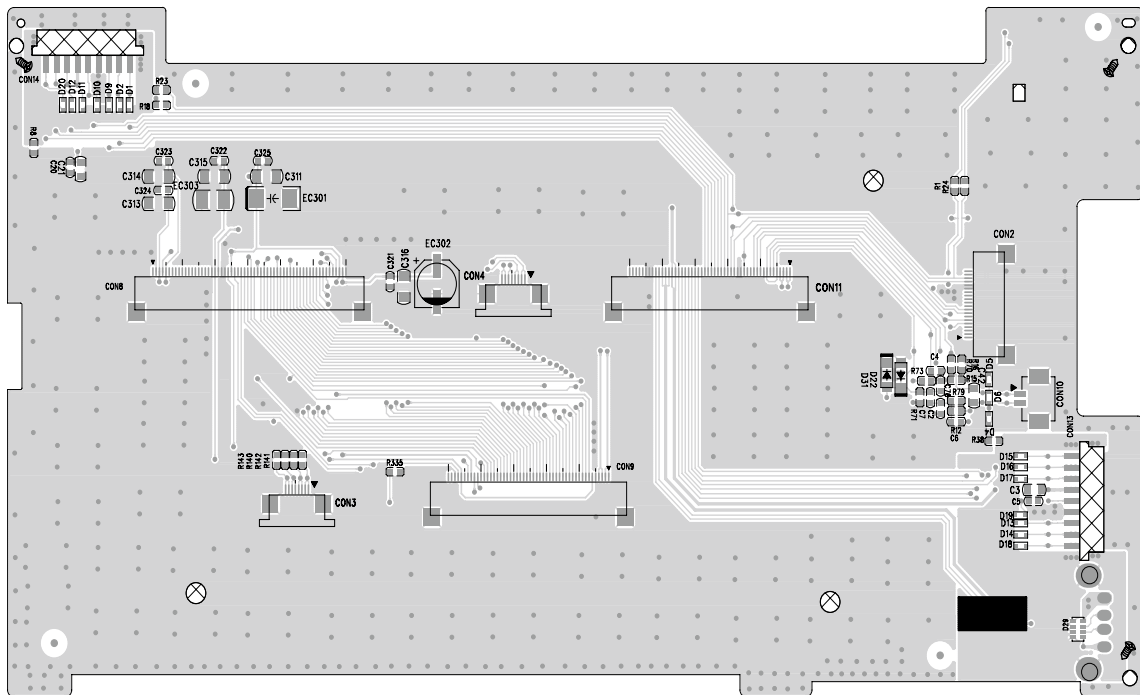

KB - PCB LAYOUT VIEW

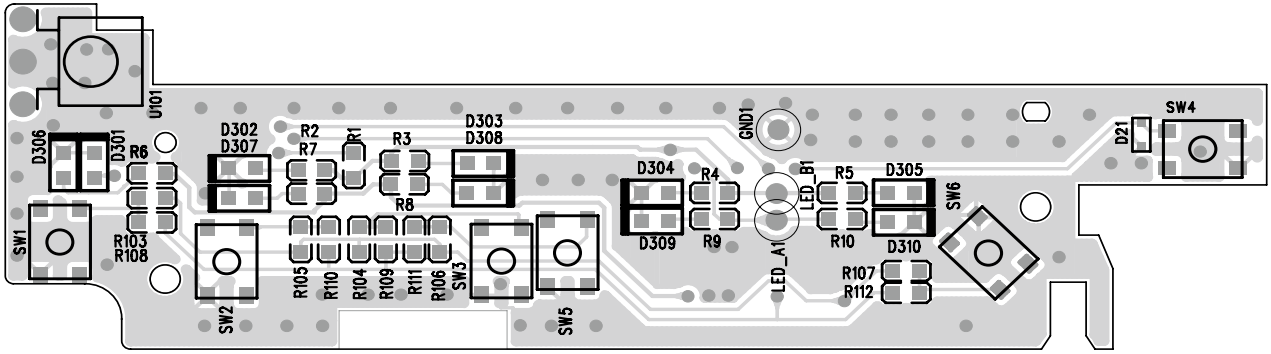

KB - PCB LAYOUT VIEW

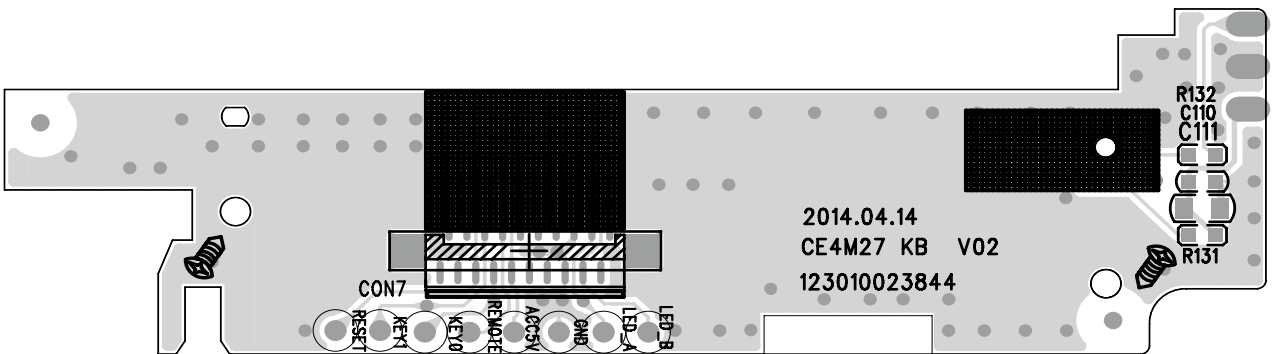

ISO - CIRCUIT DIAGRAM

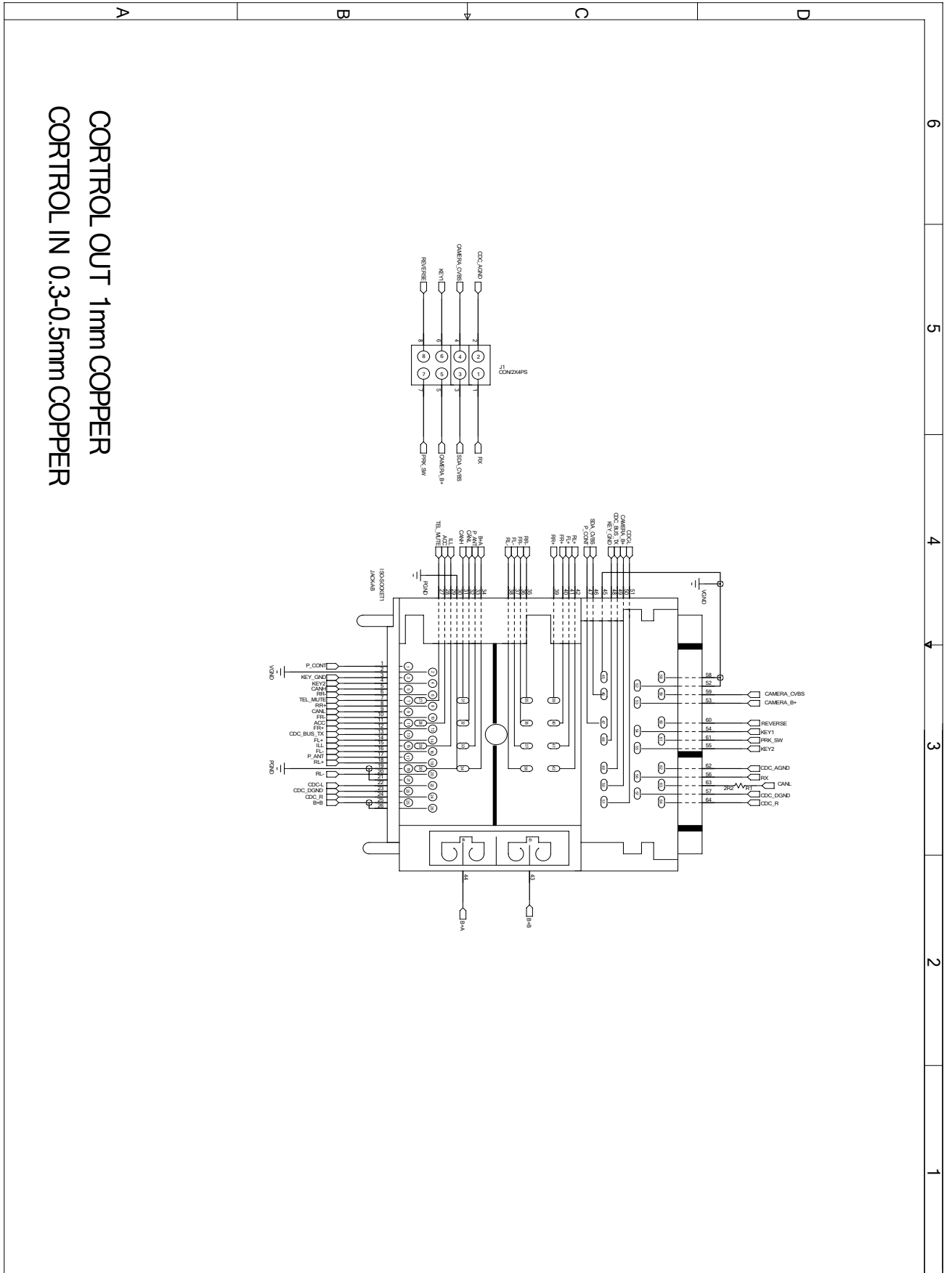

CORTRROL OUT 1mm COPPER
 CORTRROL IN 0.3-0.5mm COPPER

ISO - PCB LAYOUT TOP VIEW

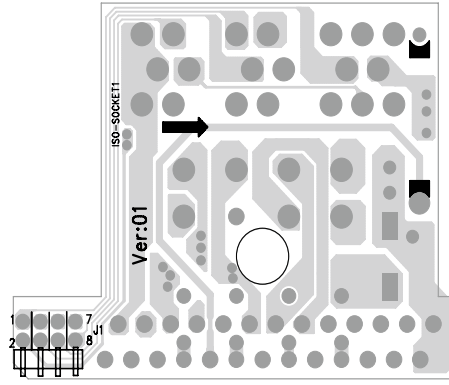

ISO - PCB LAYOUT BOTTOM VIEW

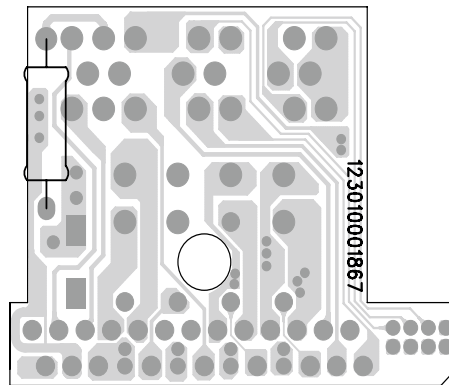

SD - CIRCUIT DIAGRAM

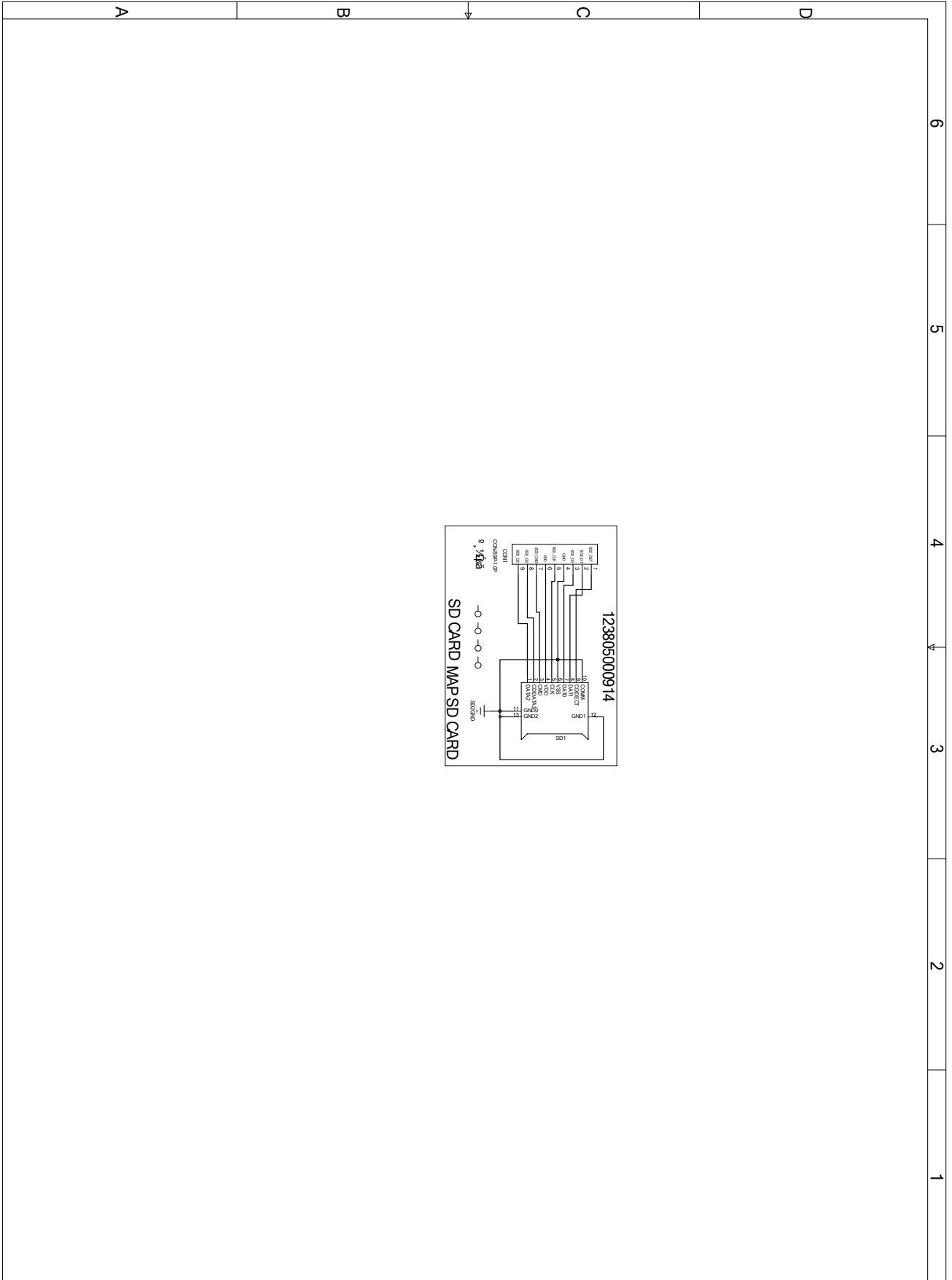

SD - PCB LAYOUT TOP VIEW

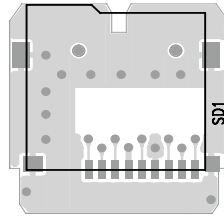

SD - PCB LAYOUT BOTTOM VIEW

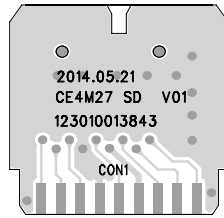

TUNER - CIRCUIT DIAGRAM

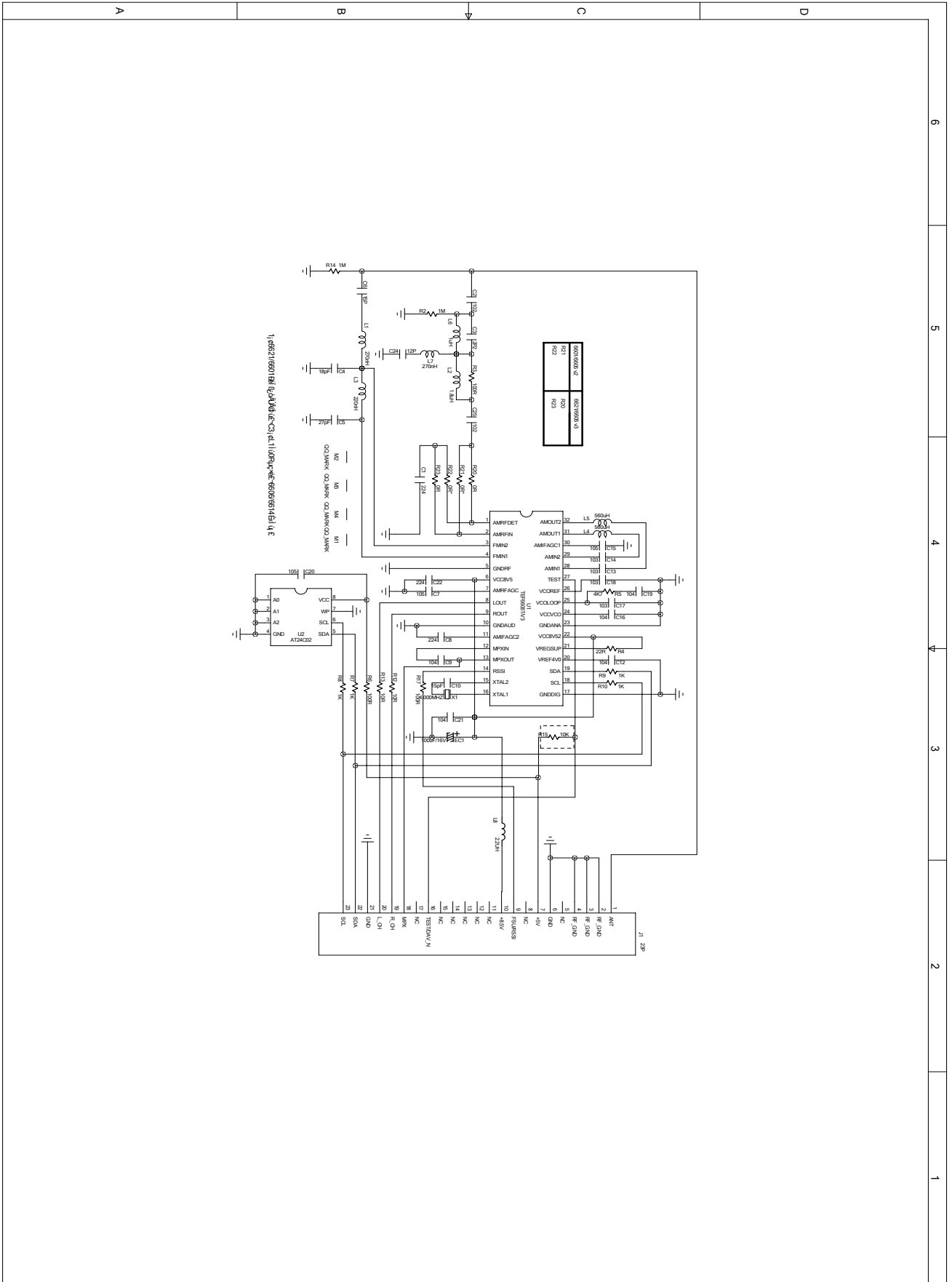

TUNER - PCB LAYOUT TOP VIEW

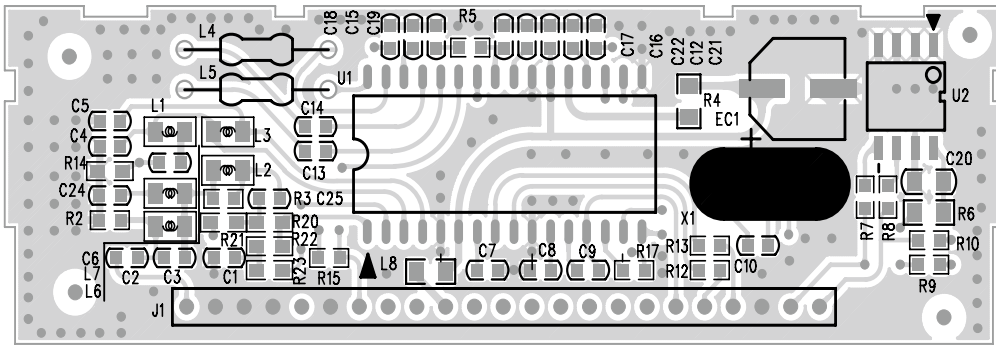

TUNER - PCB LAYOUT BOTTOM VIEW

