

THESIS

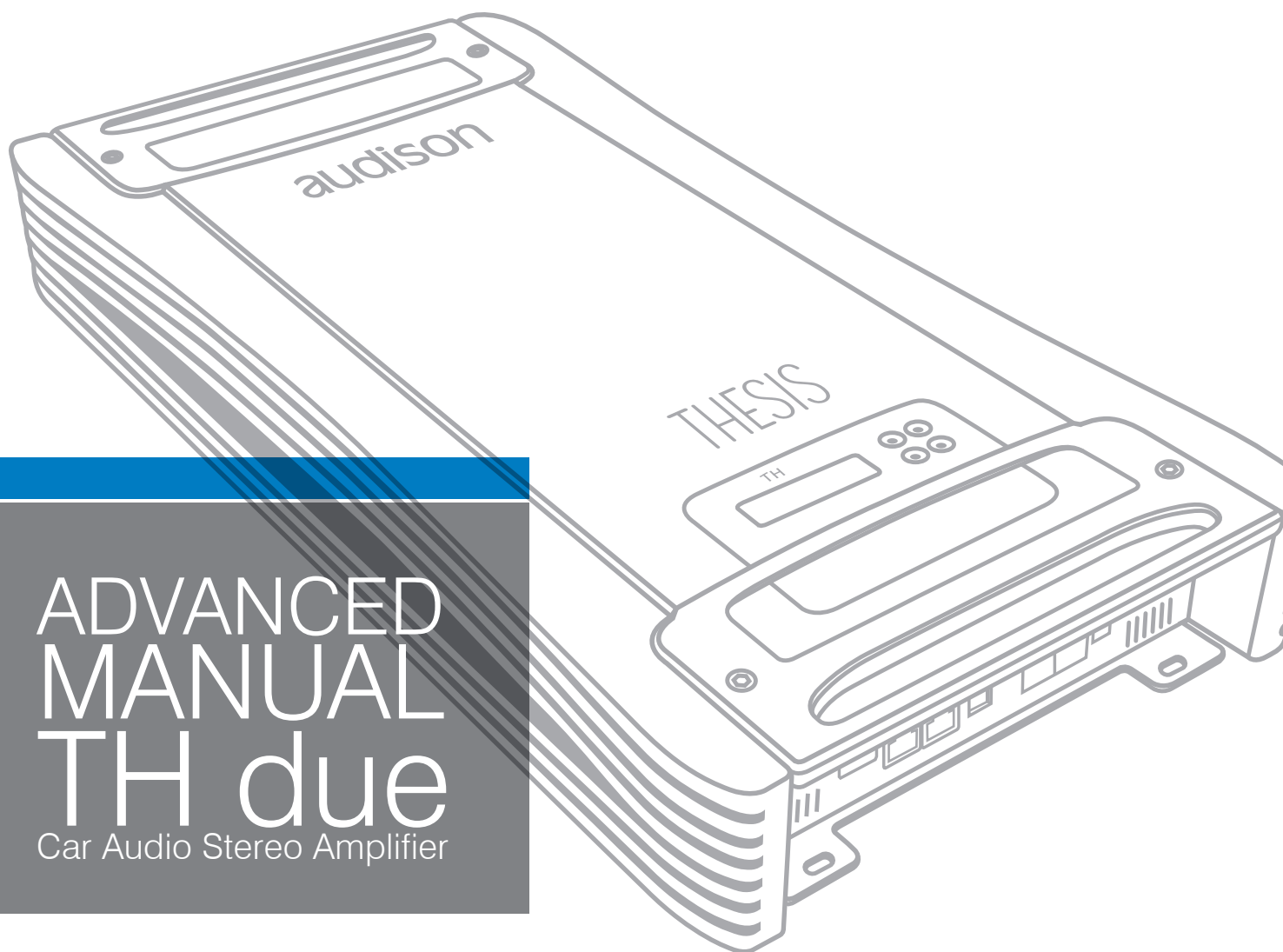

ideato,
progettato,
costruito
in Italia



ADVANCED MANUAL TH due

Car Audio Stereo Amplifier

audison
www.audison.eu



INDEX

THESIS - The project	4
Packaging Contents	5
Installation	6
Fixing template	7
Rear Panel	11
Functions Description	11
How to remove the panel / the protection knob	11
How to connect the power supply	12
How to replace the fuse	13
How to connect the speakers in stereo mode	14
How to connect the speakers in mono mode MIX L+R	15
How to connect the speakers in mono mode IN R	16
Input controls	17
Functions Description	17
How to move from one sensitivity range to another	17
Front Panel	18
Functions Description	18
How to connect the remote	19
How to connect the source through the preamplified analog input (Stereo mode)	20
How to connect the source through the preamplified analog input (Mono MIX L+R mode)	21
How to connect the source through the preamplified analog input (Mono IN R mode)	22
Electronic Crossover	23
TH in Stereo mode	24
TH in Mono mode (Setup X-Over Slope 12 dB)	25
TH in Mono mode (Setup Lo-Pass X-Over Slope 24 dB)	26
How to insert	27
Examples	28
Two Way, mono configuration, TH amplifier, Analog Input	28
Two Way + bi-amplified Sub, Th amplifier, Analog Input	29
Three Way + multi-amplified Sub, TH amplifier, Analog Input	30
Two Way + bi-amplified Sub, with and without Th amplifiers, Analog Input	31
Three Way + multi-amplified Sub, with and without Th amplifiers, Analog Input	32
THESIS	33
ASC (AMPLIFIER STATUS CONTROLLER)	33
INPUTS AND PRE-AMPLIFIER	33
ASC - Amplifier Status Controller	34
Functions Description	34
Setup Amplifier: Main Input	35
How to change: main Input (Stereo or Mono mode)	35
Digital Inputs	36
How to adjust the volume control and input selector using a digital source	36
Front Panel	37
How to achieve same output volume level using an analog source (with its own volume control) and a digital source	37
How to connect a source through the optical digital input in a system featuring more then one TH amplifier (Stereo mode)	38
How to connect a source through the optical digital input in a system featuring other non-TH amplifiers (Stereo mode)	39
How to connect a source through the optical digital input in a system featuring more then one TH amplifier (Mono MIX L+R mode)	40
How to connect a source through the optical digital input in a system featuring other non-TH amplifiers (Mono MIX L+R mode)	41
How to connect an analog and a digital source in a system featuring more than one amplifier (Stereo mode)	42



INDEX

How to connect an analog and a digital source in a system featuring other non-TH amplifiers (Stereo mode)	43
How to connect an analog and a digital source in a system featuring more than one amplifier (Mono MIX L+R mode)	44
How to connect an analog and a digital source in a system featuring other non-TH amplifiers (Mono MIX L+R mode)	45
ASC - Amplifier Status Controller	46
Setup Amplifier: Amp ID (TH in Stereo mode)	46
Setup Amplifier: Amp ID-Preout (TH in Stereo mode)	47
Setup Amplifier: Amp ID and ID-Preout (TH in Mono MIX L+R)	48
Setup Amplifier: Amp ID and ID-Preout (TH in Mono IN R)	49
Front Panel	50
How to adjust the PRE OUT analog output	50
ASC - Amplifier Status Controller	51
Setup Amplifier: X-Over Slope with TH in Mono mode	51
DUAL POWER & BIAS CONTROL	52
Setup Amplifier: DUAL POWER Settings	52
DUAL POWER Values	53
How to change presets oin the Memory	54
Examples	55
Three Way + multi-amplified Sub, TH amplifiers, Digital Input	55
Three Way + multi-amplified Sub, Th amplifiers, Analog + Digital Input	56
Three Way + multi-amplified Sub, with both TH and non-TH amplifiers, Analog + Digital Input	57
ASC - Amplifier Status Controller	58
Status Monitor	58
Runtime Monitor	59
Info and Alert sentences	60
DRC - Digital Remote Control	61
nfo and Alert sentences	62
How to connect	63
How to install	63
ACNet - Audison Control Network	64
Function Description	65
System Display	66
Amplifier Setting: Identification	67
Amplifier Setting: Inputs	68
Amplifier Setting: Sensitivity and Preout Level	69
Amplifier Setting: Dual Power Memory	70
System Audio Control	71
Amplifier Status	72
System Amplitude Setup	73
System Dual Power Setup	74
Technical Specifications	75



THESIS

The Project

The roads travelled to reach “the Sound” have created a conceptual cross-road, where state of the art digital technology and traditional techniques have gone their separate ways.

They both have benefits of a different nature, yet are capable of merging together to achieve much higher Sound quality levels.

The Thesis amplifiers are born from these considerations. The parts related to signal amplification are manufactured using the highest level of analog technology while, at the same time, the input section along with the processing and monitoring functions of the amplifier are the result of the most advanced digital technology.

The TH due is a two-channel power amplifier, designed for use in car. It is technologically progressive, featuring original circuitry, with extraordinary sound, consistent with Audison tradition.

Sections:

This manual is divided into sections allowing the use of the TH amplifier in standard settings or using its specific features in “digital” settings. Each section is marked by its corresponding bookmark.

General Part:

The TH amplifiers need to be connected like any other amplifier, in compliance with safe working conditions. Installation as well as power supply and speaker connections have to be made properly, following the standard methods a specialty store normally follows.

Classic Domain:

Despite the endless settings and customising possibilities ASC (Amplifier Status Controller) offers, the TH amplifiers can also be used in a traditional way, taking advantage of the analog inputs and of the controls which provide the signal to the final stages.

The setting of the sensitivity, stereo or bridged mono configuration, the inputs sensitivity, the electronic crossovers on slide-through boards as well as the PRE bypass out, anyway let to include the TH within the traditional systems or to build amplifying chains with absolute audiophile quality.

Digital Domain:

The TH amplifiers feature ASC (Amplifier Status Controller) which provides several factory functions for the complete control of all the amplifier's functions.

Heart of the system is a digital power microprocessor. It manages the amplifier functions and communicates with the user through a control panel as well as the Display Monitor, featuring the DRC remote control or, in a more complete and direct way, through the ACNet Audison Controller Network software.

The ASC menu allows the amplifier set up, monitors the working conditions, viewable through a Status Monitor feature, also making the data available on the display intermittently. A USB connector enables the connection of the system to a computer, while the AC Link (Audison Control Link) allows the creation of communication network. The software will take care of the functional operations for all the amplifiers within the whole chain (system), providing a simple and complete interface. A revolutionary method for configuration which, up to know, were impossible to achieve with traditional designs.



Packaging Contents

- TH due amplifier

- Printed Quick Start Guide

- 1.0 m AC Link (RJ-12) cable

- 1.0 m AD Link (RJ-45) cable

- 2.0 m USB cable

- USB/AC Link converter

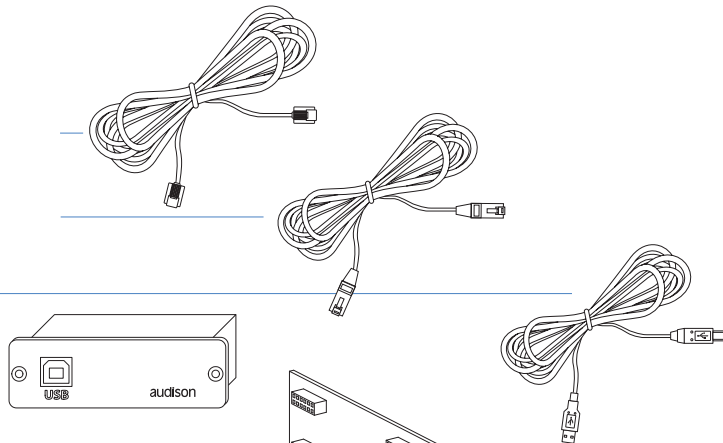

- TH crossover kit composed of:

- N. 1 TH-MXR stereo module

- N.8 frequency set modules (SS1-SW1-SW2-WM1-WM2-MT1-WT1-MT2)

- N. 2 CFB customizable modules

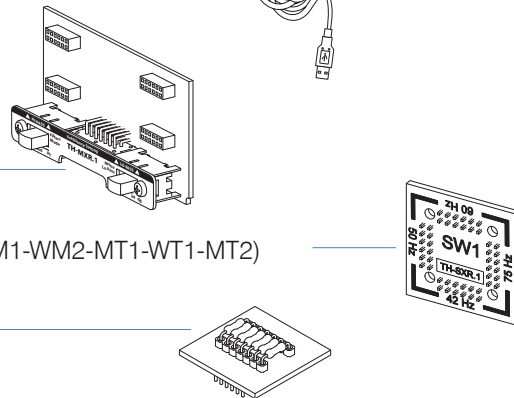

- N. 4 Fixing screws and plastic bushing

- Multispanner tooling

- 100 A AFS spare fuse



- INSTALLATION CD with:

- CD ROM
- ACNet Software
- This Advanced Manual (.pdf)
- AC Link Drivers
- USB-ACNet Drivers

TEST SIGNALS

- Track_01. sine sweep (0 dB) - 10 min
- Track_02. white noise (-12 dB) - 15 min
- Track_03. pink noise (0 dB) - 10 min
- Track_04. sine wave 50 Hz (0 dB) - 2 min
- Track_05. sine wave 1 kHz (0 dB) - 2 min

Available accessories (not provided):

DRC - Digital Remote Control

- DRC control panel

- 4.5 m DRC/AC Link cable

- N.2 fixing brackets

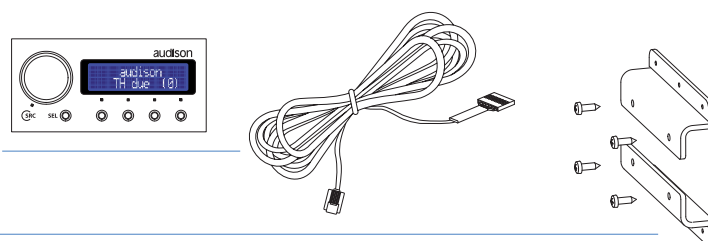



Installation

External size

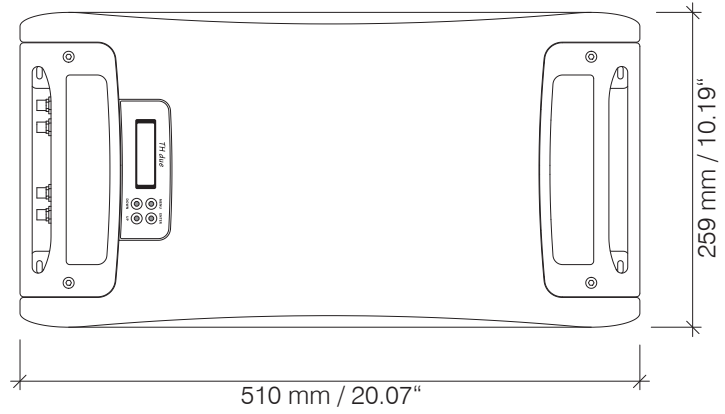

How to fix

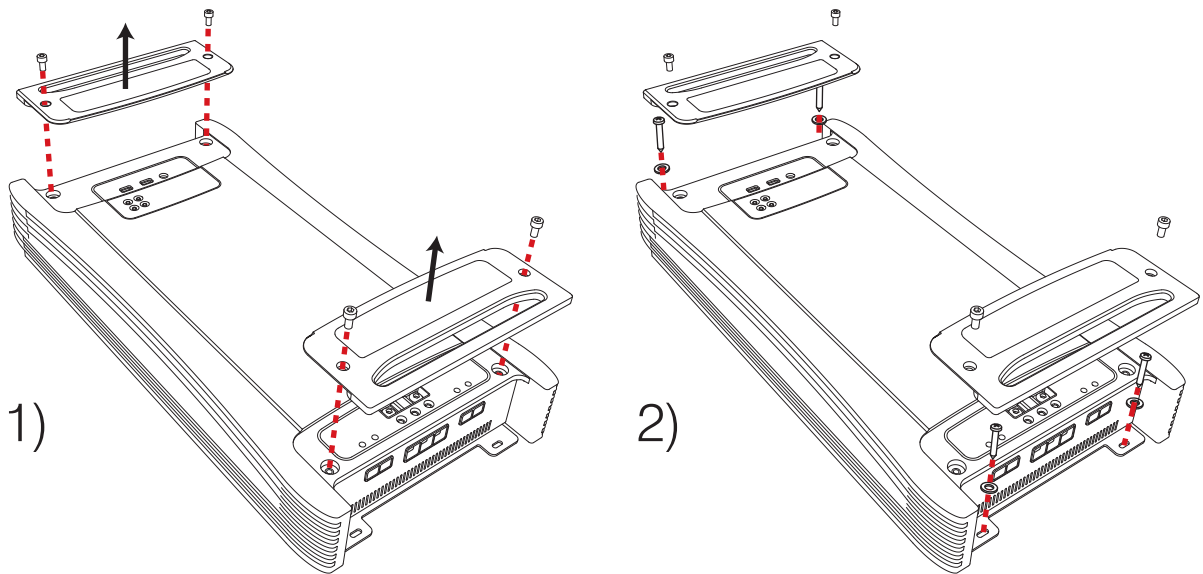

Fixing size

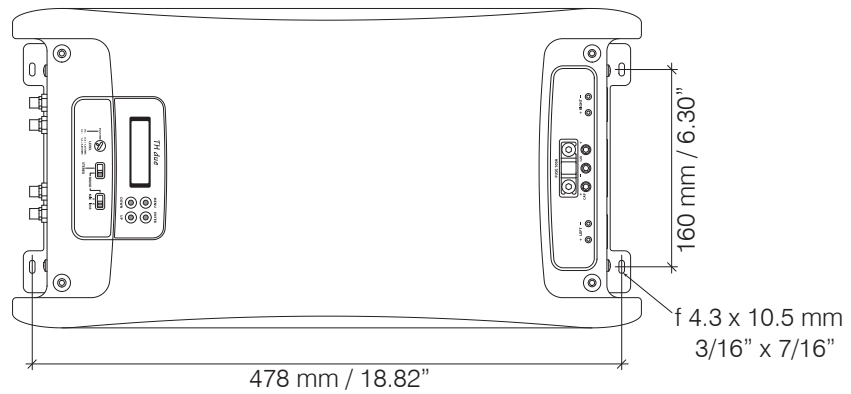

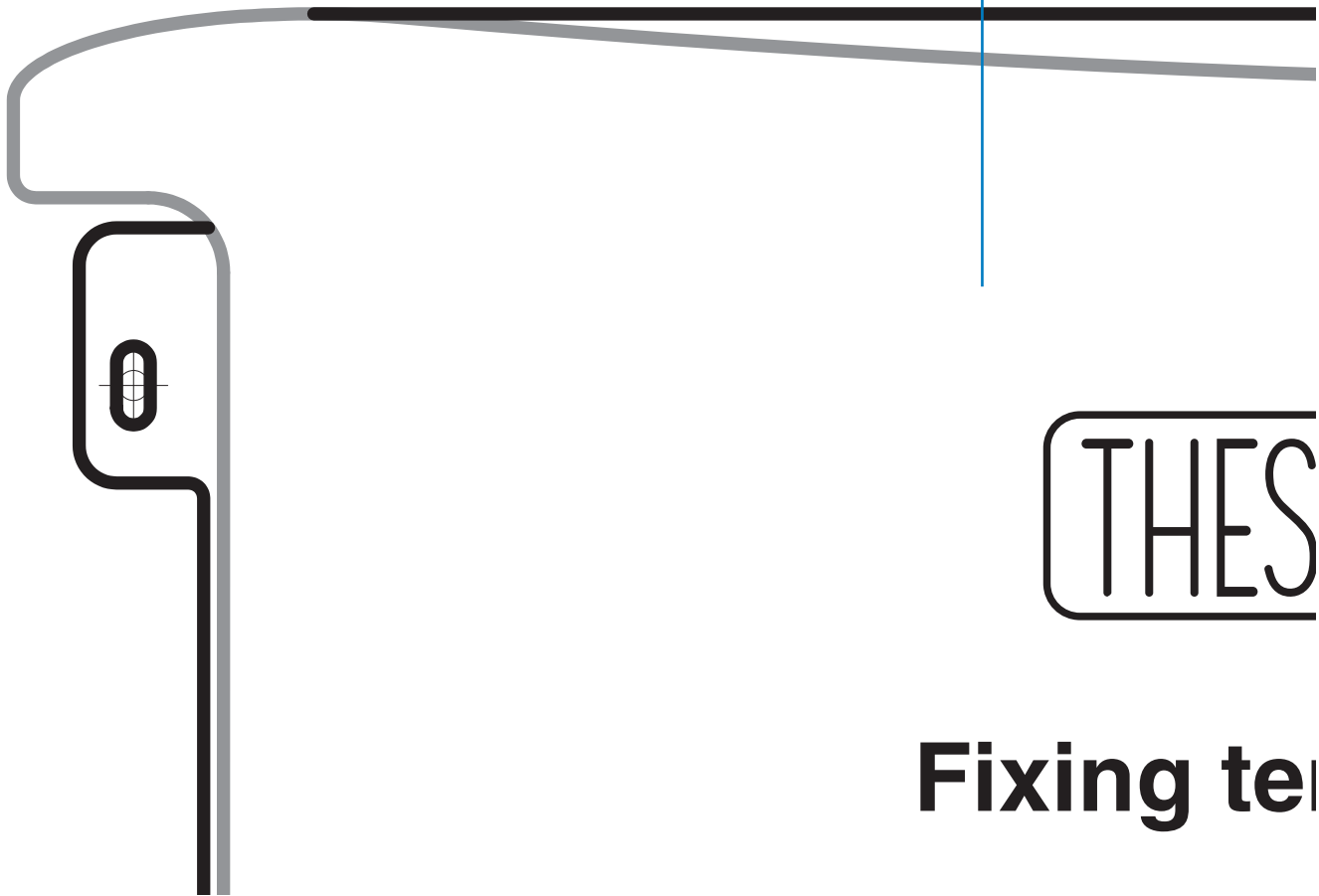

THESE

Fixing te

Warning: to properly print the template at the real size, select the "None" option into the "Page Scaling" setup. After printing, cut the sheets along the blue reference line and then glue them.

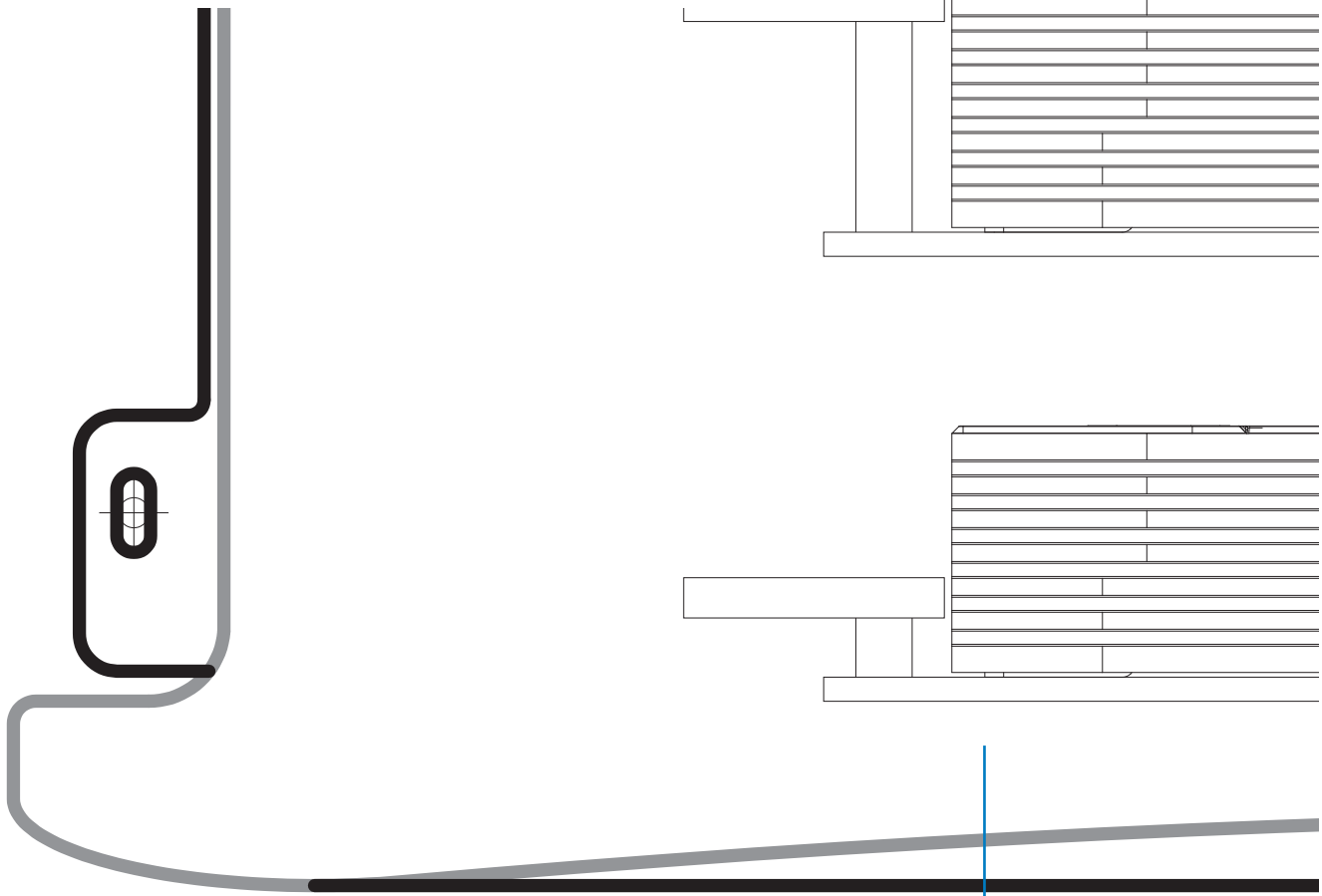

THESIS

Fixing template

A

A
B

A

B

A

B

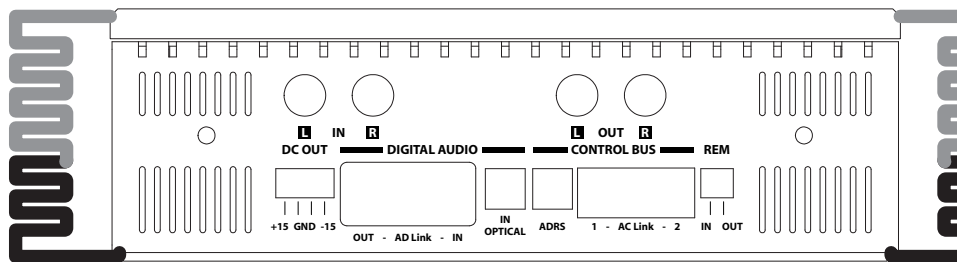

Mode A

level panel

spacer

66 mm (2.6")

Mode B

level panel

spacer

26 mm (1.02")

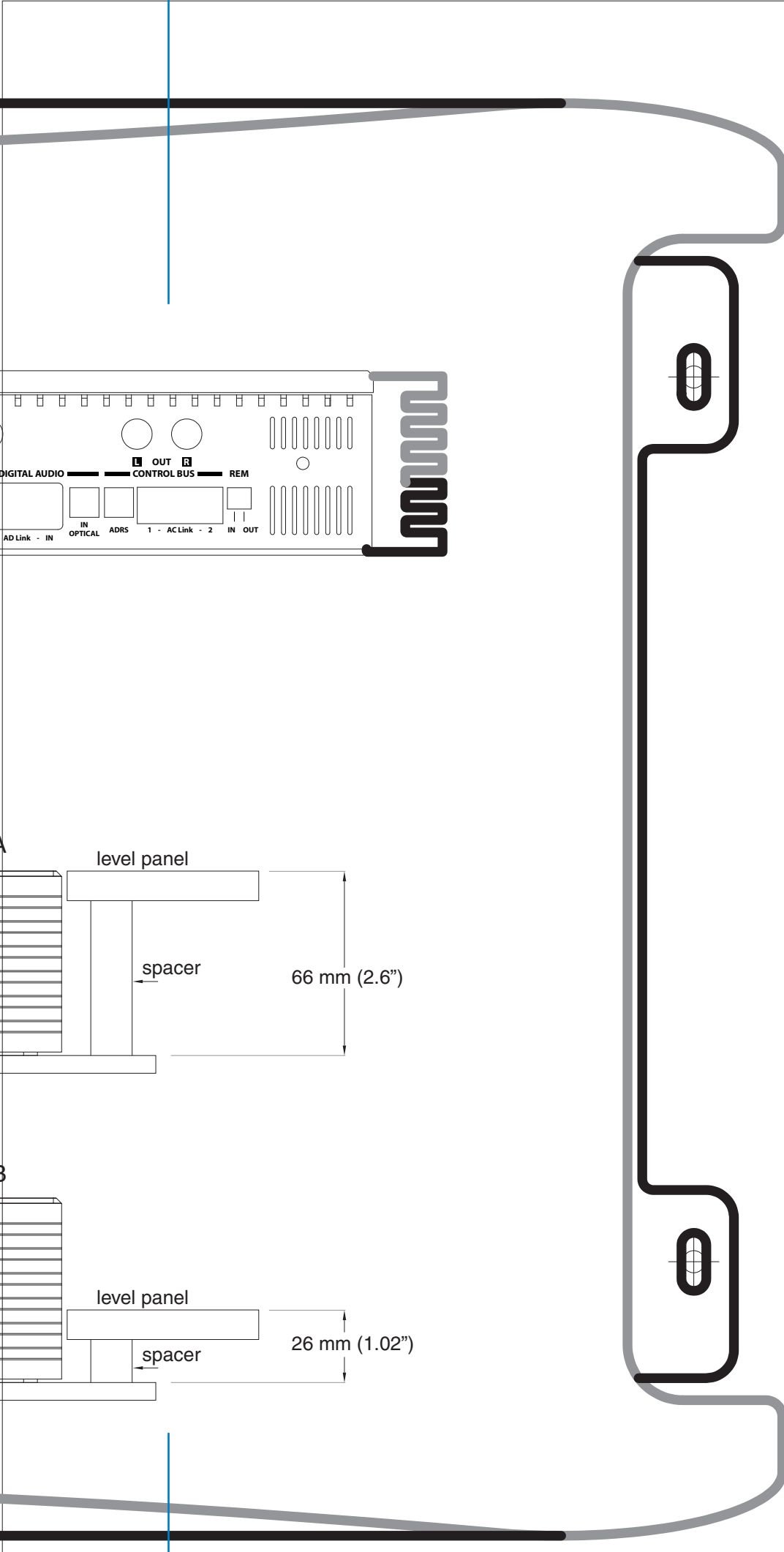

Rear Panel

Functions Description

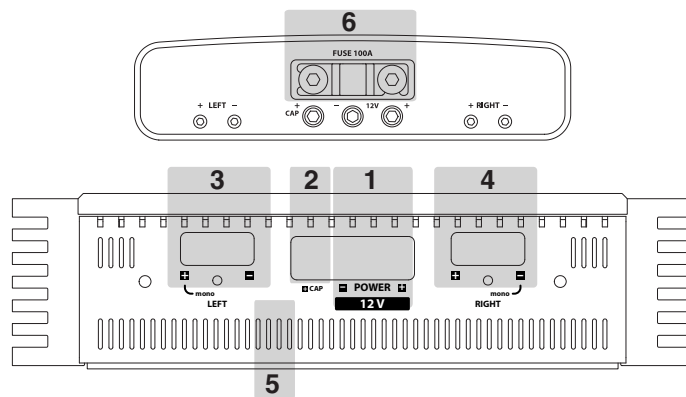

- 1 • **POWER:** Positive and negative terminals for 12 V car voltage supply. Size of connectors is 10 mm diameter (2 AWG). Warning: connect positive and negative (GND) with polarity as indicated in the terminal. A wrong connection cause an amplifier damage.
- 2 • **+CAP:** Terminal to connect positive pole of external capacitor.
- 3 • **LEFT:** Terminals to connect Left speakers system. Size of connectors is 6 mm (6 AWG). Pay attention to connect speaker with polarity as indicated, wrong polarity causes a phase problem in the audio system.
- 4 • **RIGHT:** Terminals to connect Right speakers system. Size of connectors is 6 mm (6 AWG). Pay attention to connect speaker with polarity as indicated, wrong polarity causes a phase problem in the audio system.
- 5 • **MONO:** Terminals to connect mono speaker system if the amplifier is configured in mono (Bridge). See Input Controls section.
- 6 • **FUSE:** Protection Fuse Connection Audison AFS 100 A.

How to remove the panel / the protection knob

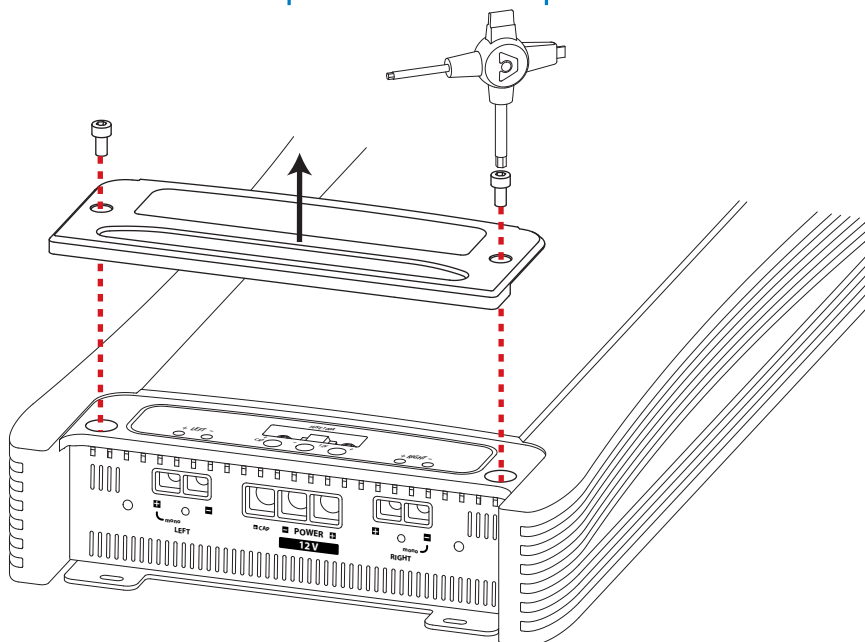

Rear Panel

How to connect the power supply

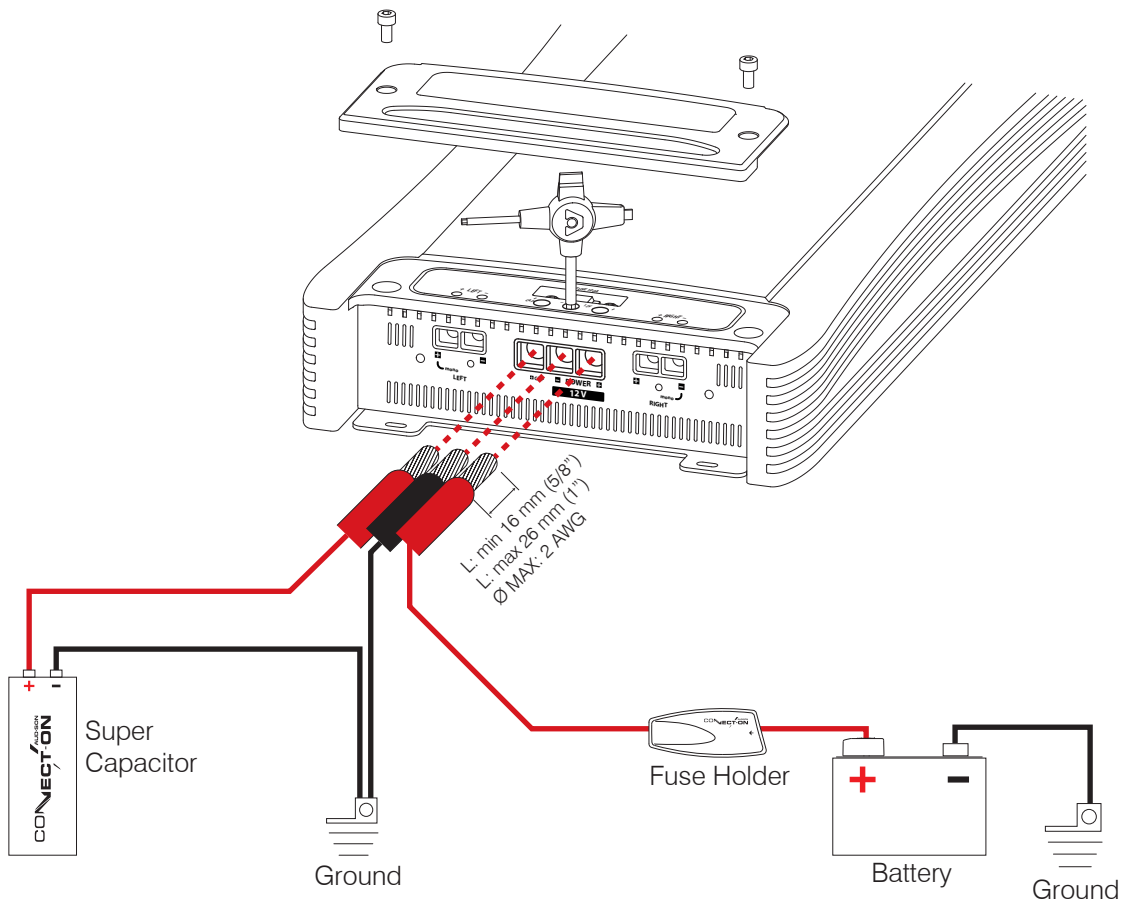

Rear Panel

How to replace the fuse

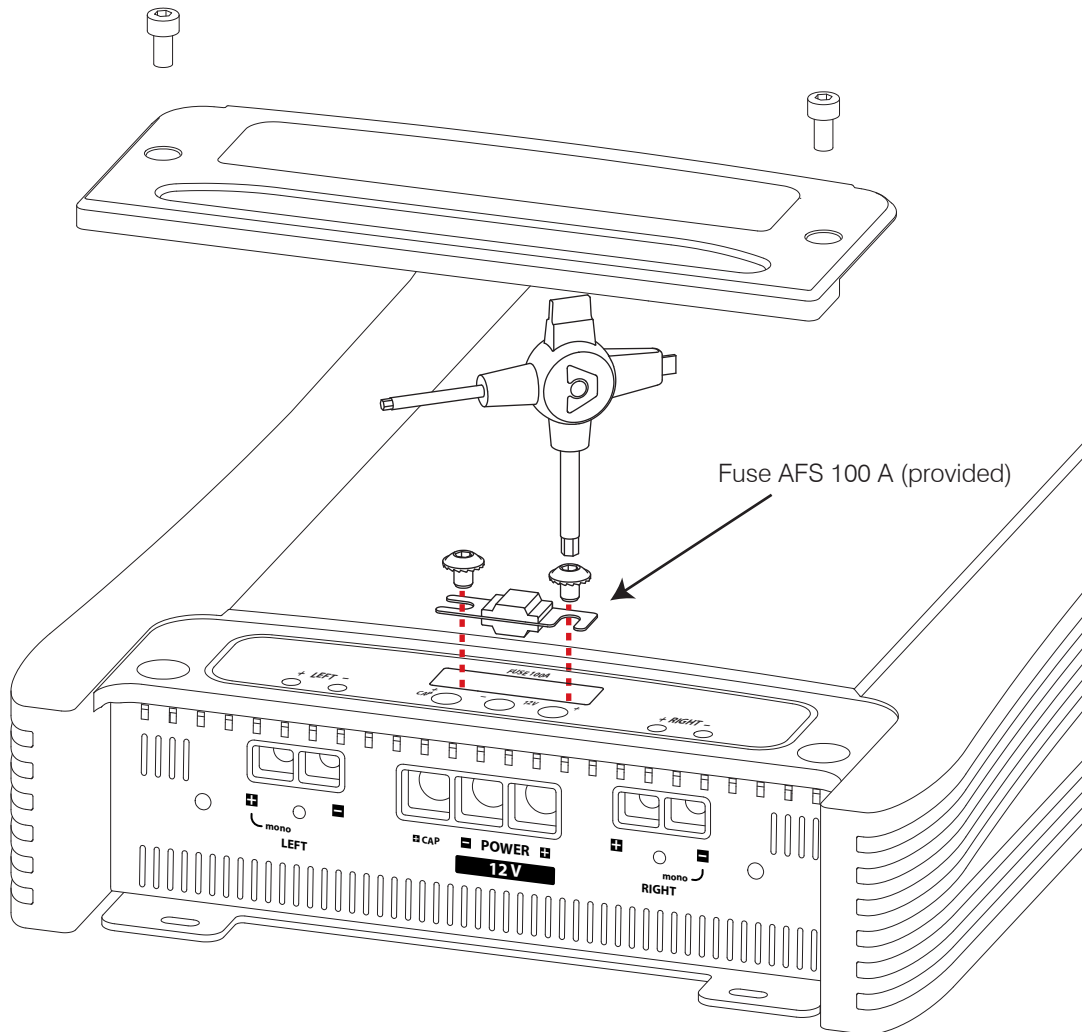

Rear Panel

How to connect the speakers in stereo mode

About Input's configuration see pages:

- 20 ÷ 22 – Analog Input
- 38 ÷ 45 – Digital Input

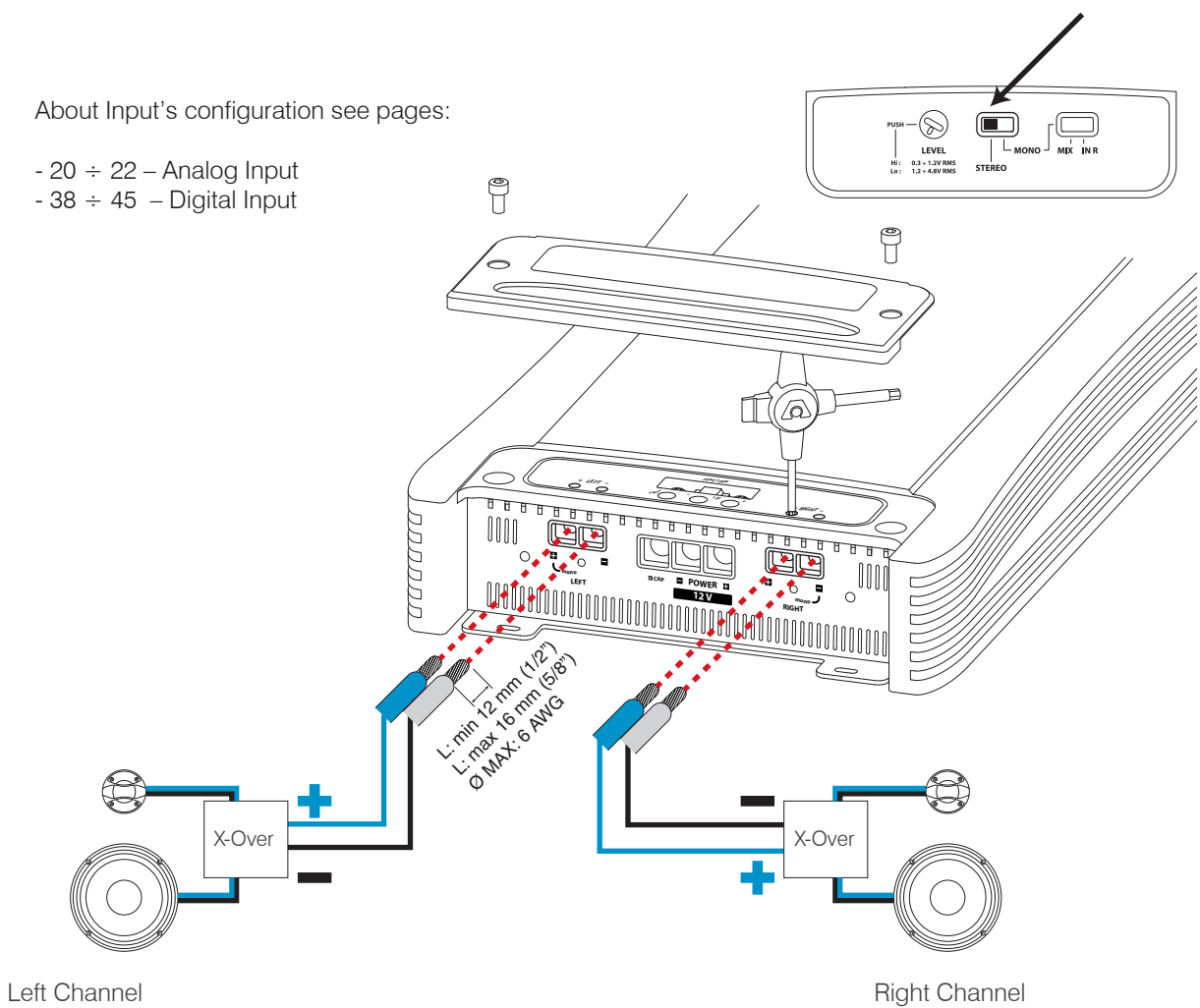

Rear Panel

How to connect the speakers in mono mode MIX L+R

Useful to drive a Subwoofer or a central channel by giving a stereo signal in input and having the electric sum of the right and left channel coming out, plus the possible action of the internal electronic filter crossovers if featured.

About Input's configuration see pages:

- 20 ÷ 22 – Analog Input
- 38 ÷ 45 – Digital Input

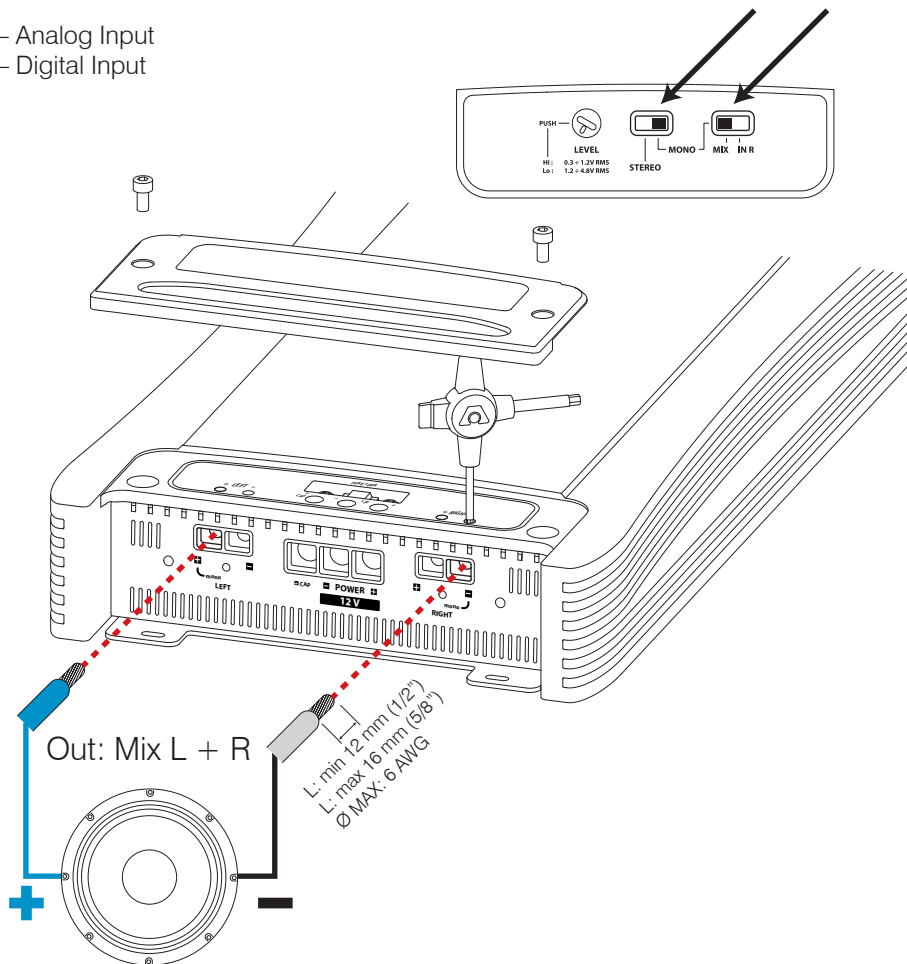

Rear Panel

How to connect the speakers in mono mode IN R

Useful to drive a Subwoofer, a central channel or any amplified system in Dual Mono, by means of a mono signal in input and having the same signal going out, plus the possible action of the internal electronic filter crossovers if featured.

About Input's configuration see pages:

- 20 ÷ 22 – Analog Input
- 38 ÷ 45 – Digital Input

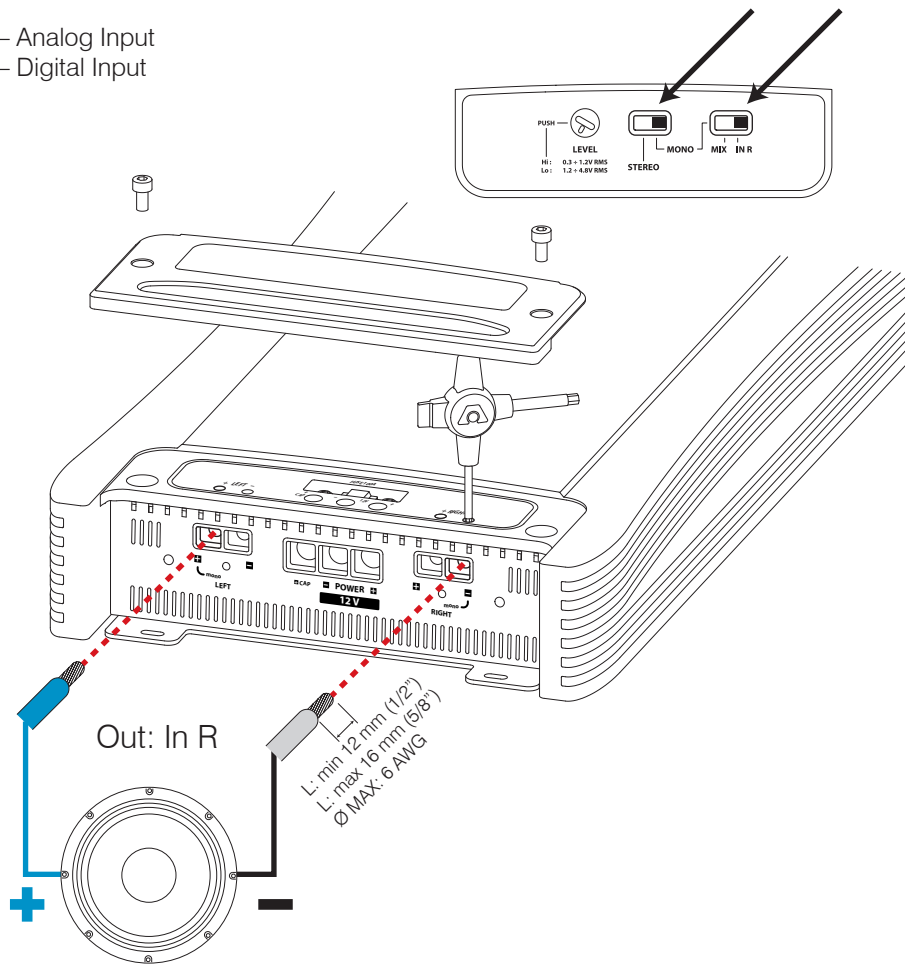

Input controls

Functions Description

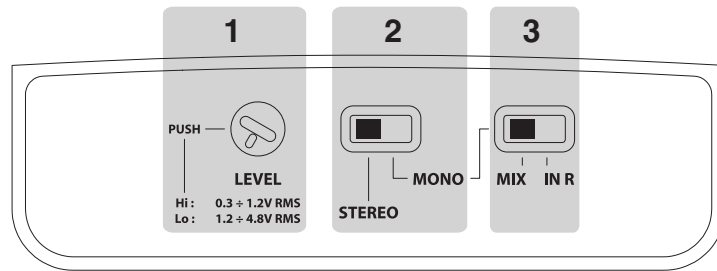

- 1 • **LEVEL:** Adjusts both channels input sensitivity. It features 2 ranges, one “Hi” from .3 to 1.2 VRMS and another “Low” from 1.2 to 4.8 VRMS. By keeping the knob pushed for three seconds you can change the range. To see voltage value and range, check the ASC display. Those controls are also available if ACNet software is used.
- 2 • **STEREO-MONO:** By setting the switch on “Stereo” or “Mono” mode, the amplifier works in Stereo or Mono (Bridge). When “Mono” is selected, the switch MIX / IN R is enabled.
- 3 • **MIX / IN R:** If set on “MIX”, this switch enables the Left and Right inputs to drive the amplifier by mixing both signals. When set on “IN R”, only the Right input signal drives the amplifier.

How to move from one sensitivity range to another

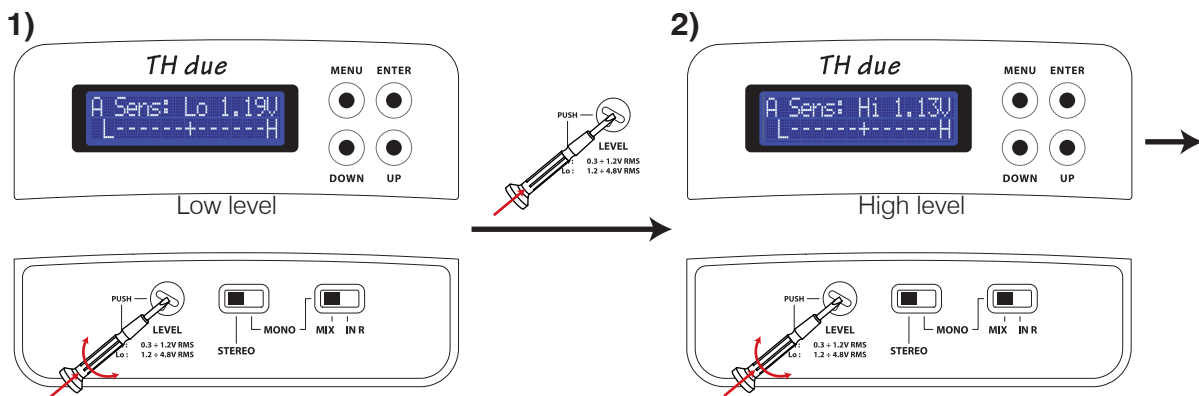

TURN THE KNOB TO REGULATE THE LEVEL
PRESS THE KNOB FOR 3" TO CHANGE
THE RANGE FROM LO TO HI

TURN THE KNOB TO REGULATE THE LEVEL
PRESS THE KNOB FOR 3" TO CHANGE
THE RANGE FROM HI TO LO



WARNING: be careful when passing from LO to HI level!

NOTE: sensitivity is automatically set on the lowest value of Hi Level range, but the difference between the two levels could be dangerous for your system.

Front Panel

Functions Description

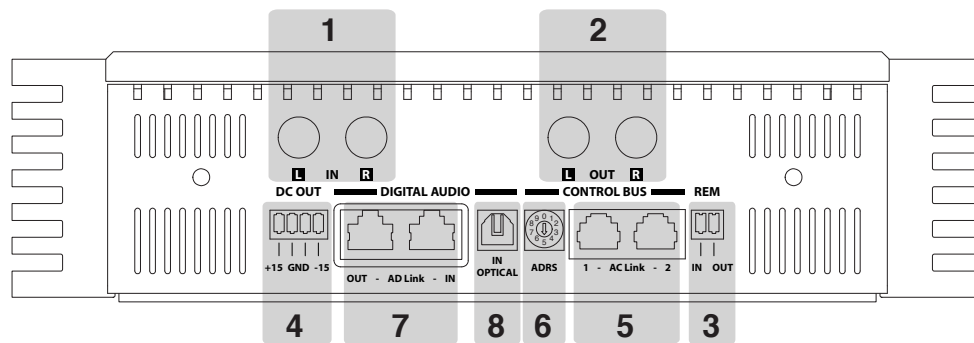

- 1 • IN L/R: Analog Input Left / Right
- 2 • OUT L/R: Bypass Analog Output Left / Right. To check out how they work see page 20 ÷ 22 and 38 ÷ 45
- 3 • REM IN/OUT: Turn On Remote Input and Output for other devices
- 4 • DC OUT: ± 15 V supply for external devices

CONTROL BUS

- 5 • AC Link 1 and 2: RJ-12 terminals to connect other devices provided with AC Link such as TH amplifiers, DRC (Digital Remote Control), Audio Digital Processors, AC Link/USB Adapter for Personal Computer connection. The use of connector 1 or 2 is interchangeable. The RJ-12 connectors provided cable is normally used for digital telephone connection. It features 6-way connectors. The AC Link connection can give power supply to the amplifier external devices.
- 6 • ADRS: It's the digital address of the amplifier when you want to realize a system with more than one TH. Switch selector from 0 to 9 to set in a different number on each TH amplifier of the AC Link network. Maximum allowed chain amplifiers number is 10.

Warning: a different number has to be assigned to each amplifier starting from number zero, otherwise the ACLink network will not work properly. The selected number is shown on the Status display between brackets.

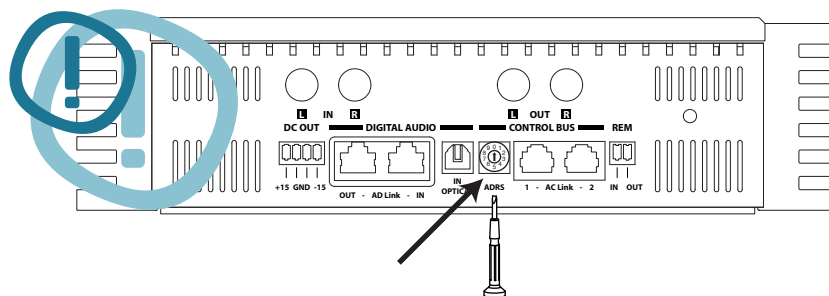

DIGITAL AUDIO IN/OUT

- 7 • AD Link: is an Audio Digital Bus that can carry 8 channels. It employs a Class 5 or 6 shielded Ethernet LAN cable with the provided shielded connectors, normally used in computer networks.
 - AD Link IN: RJ-45 terminal input to connect digital audio coming from previous TH amplifier or the provided external device AD Link such as Digital Audio Processor.
 - AD Link OUT: RJ-45 terminal output to connect to the next TH amplifier.
- 8 • OPTICAL IN: Input to connect the provided optical cable with TOSLINK connectors. The optical audio digital signal in S/PDIF standard is supplied from provided sources such as CD/DVD players. It accepts input PCM stereo signals up to 192 kHz / 24 bit.



Front Panel

How to connect the remote

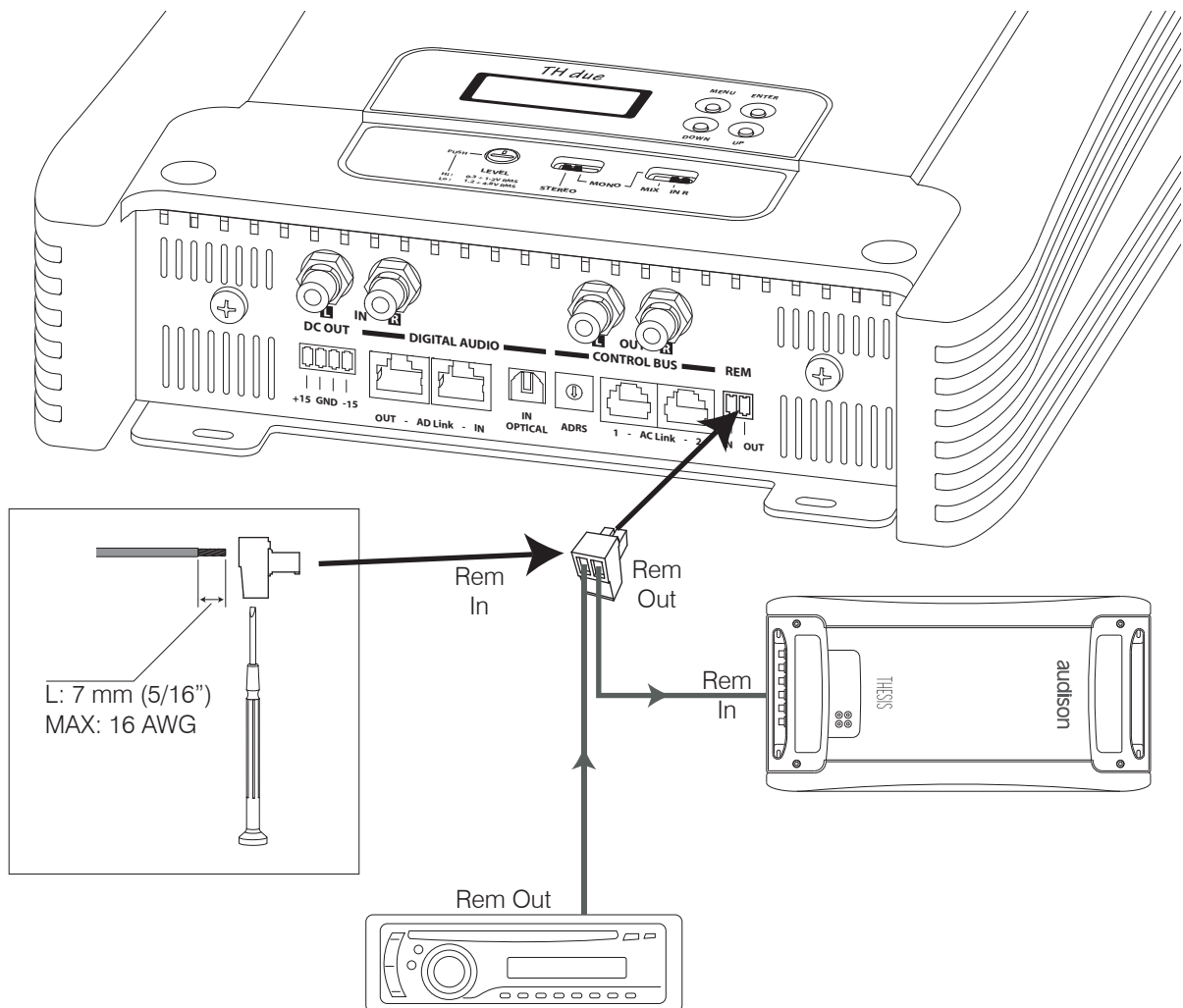



Front Panel

How to connect the source through the preamplified analog input (standard mode)

TH configured in Stereo mode

Input: Stereo Analog
Pre Out: Stereo Analog
Power Output: Stereo

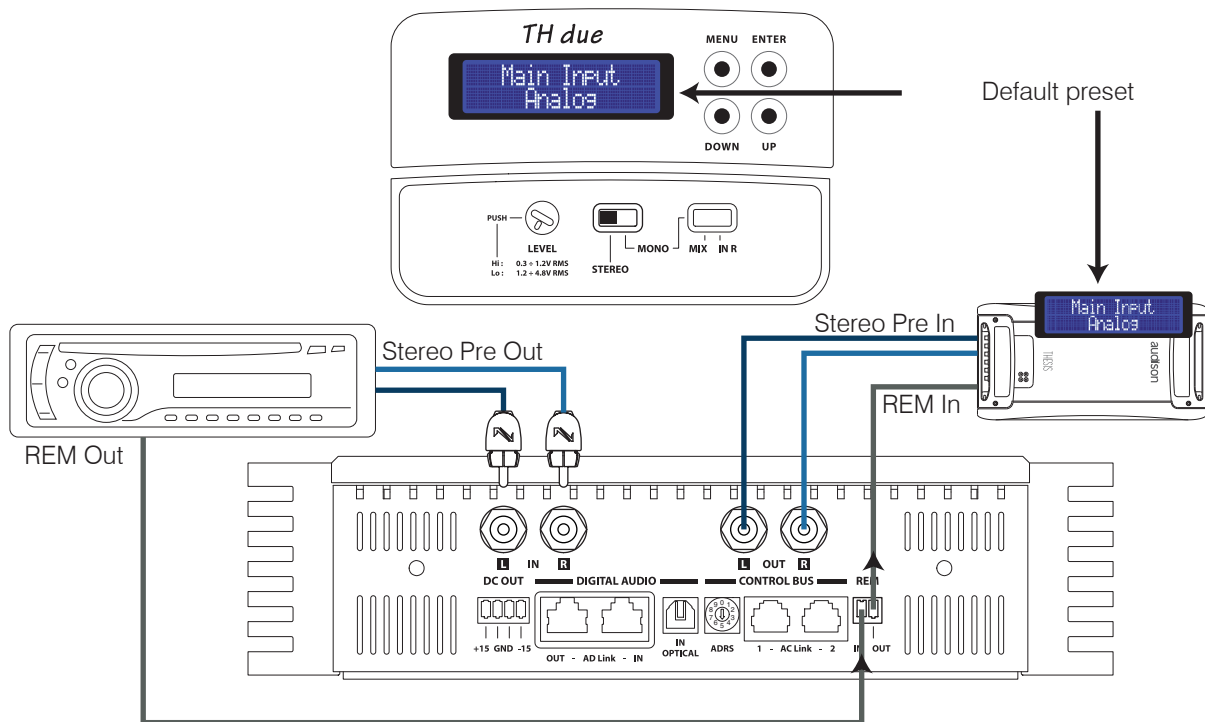

Power Output: to carry out connections, check page 12 ÷ 16

DRC: not required

PRE OUT: To cascade-connect other amplifiers when using the analog input you MUST use the Pre Out analog output.





Front Panel

How to connect the source through the preamplified analog input (standard mode)

TH configured in Mono MIX L+R mode

Input: Stereo Analog
Pre Out: Stereo Analog
Power Output: Mono MIX L+R

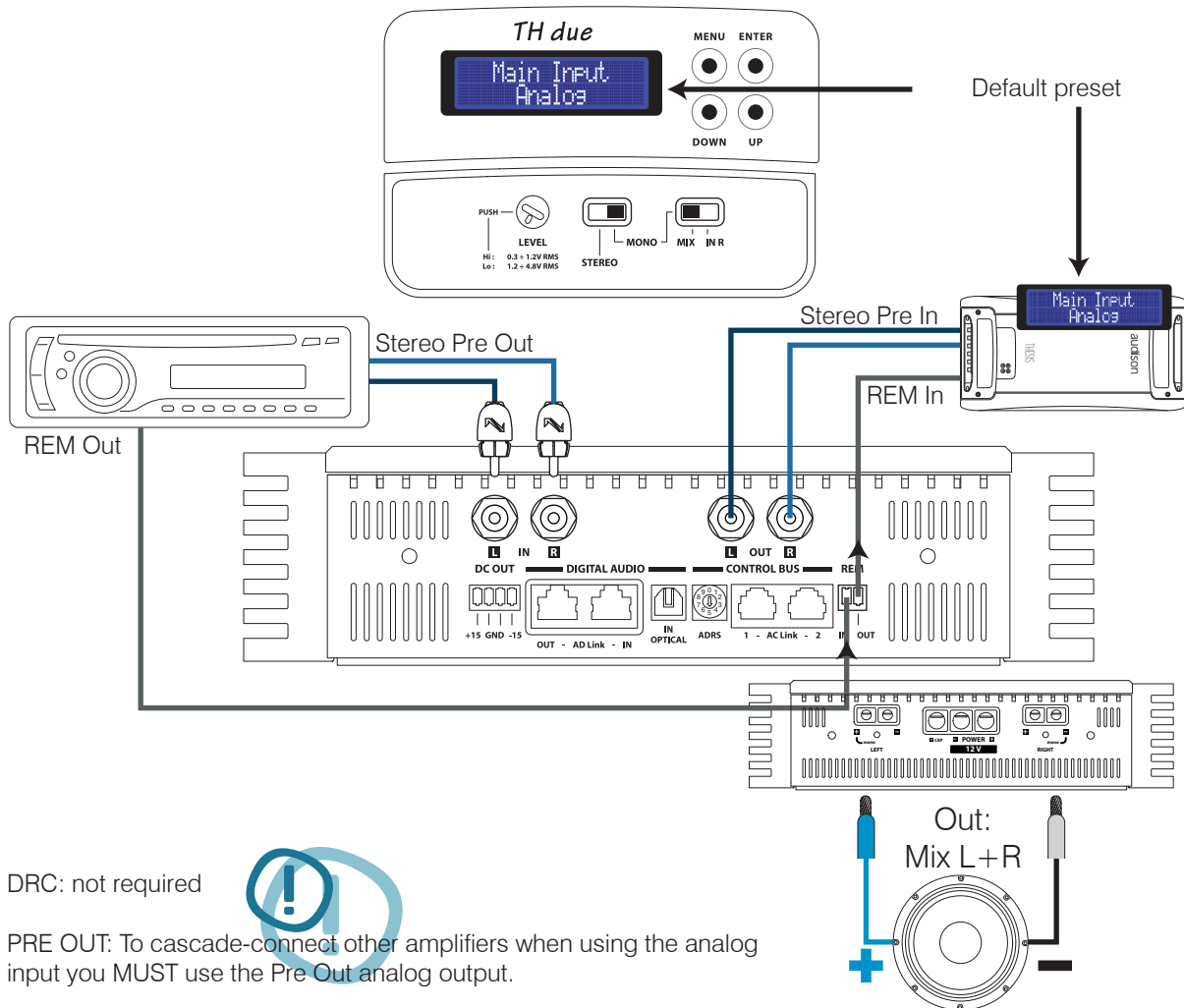

DRC: not required



PRE OUT: To cascade-connect other amplifiers when using the analog input you MUST use the Pre Out analog output.



Front Panel

How to connect the source through the preamplified analog input (standard mode)

TH configured in Mono IN R mode

Input: Mono Analog (IN R)
Pre Out: Mono Analog
Power Output: Mono IN R

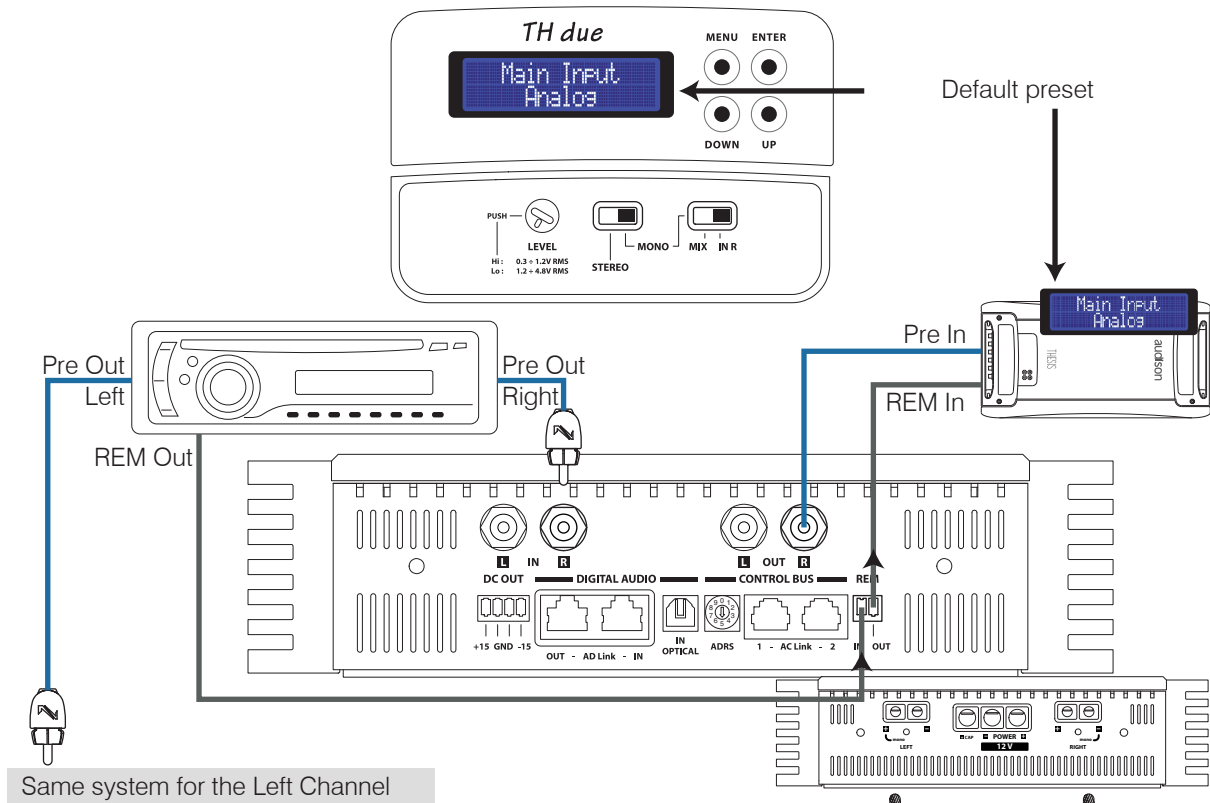

DRC: not required

PRE OUT: To cascade other amplifiers when using the analog input you MUST use the Pre Out analog output.

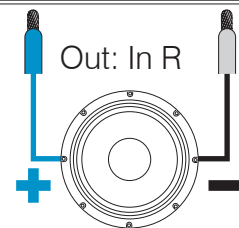

Classic domain



Electronic Crossover

Representing a high-end solution, the simplicity and power of the analog system found in the HV venti is thrust forward again in the TH, making use of the amplifiers versatility.



The crossover ONLY acts on the amplifier power output, not on the PRE OUT output which is always a bypass.

The alignment is a Butterworth type as, when either of the TH amplifiers is set up in a mono configuration, the slope of the filter can be set for 24 dB Oct operation.

Each TH due is factory provided with:

- a TH-MXR.1 crossover board, containing the electronics required to set, through selectors, the operation mode as well as the Low-Pass filter slope.
- eight crossover modules, featuring high-precision resistor packs corresponding to 32 cut-off frequencies placed at equal distance from 18Hz thru 7,5kHz.
- two customisable crossover modules (to build them, see the "Custom Module" section in this manual).

Modules

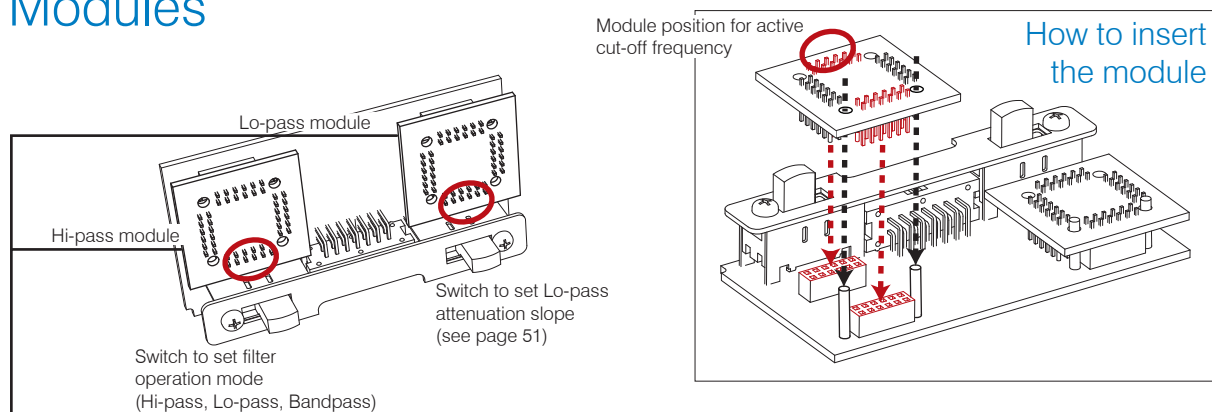

Frequency set modules: settable both in Hi-pass and Lo-pass mode

	SS1: 18-22-27-33 Hz		WM2: 420-500-600-750 Hz
	SW1: 42-50-60-75 Hz		WT1: 880-1k1-1k3-1k5 Hz
	SW2: 90-110-130-150 Hz		WT2: 1k8-2k2-2k7-3k3 Hz
	WM1: 180-220-270-330 Hz		MT1: 4k2-5k0-6k0-7k5 Hz

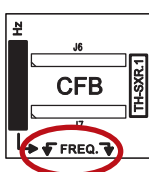

Custom Module

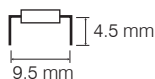

$$\text{Res (k}\Omega) = \frac{5000}{\text{Freq (Hz)}}$$

Resistor's value to use

Example: Desired cut-off frequency = 2.5 kHz $\rightarrow \frac{5000}{2500} = 2 \text{ k}\Omega$

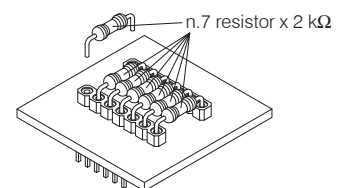

Use 1 % tolerance 0.25 W resistors



Electronic Crossover

TH in Stereo Mode

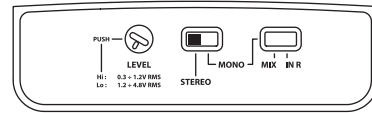

BY-PASS

**DO NOT INSERT
TH-MXR.1 MODULE**

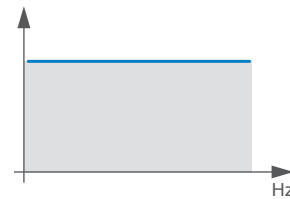

HI-PASS

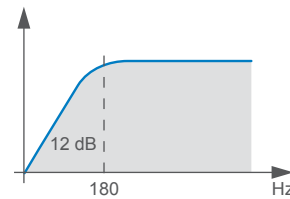
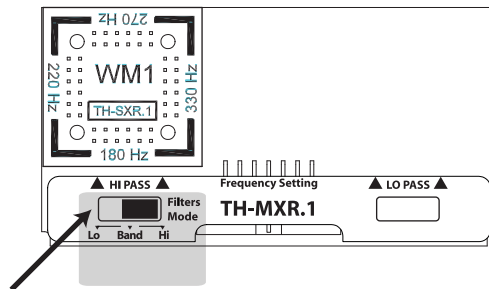

LO-PASS

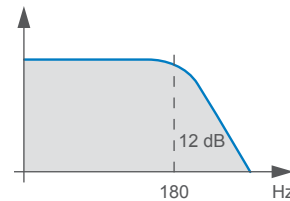
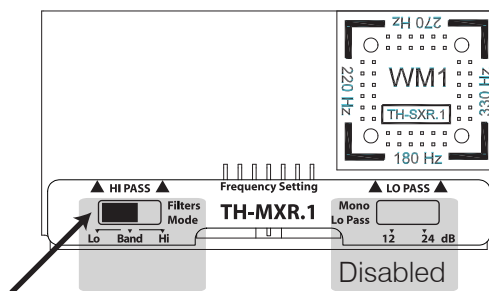

BANDPASS

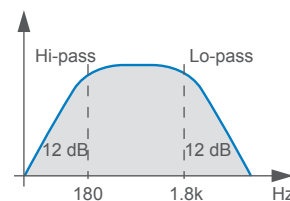
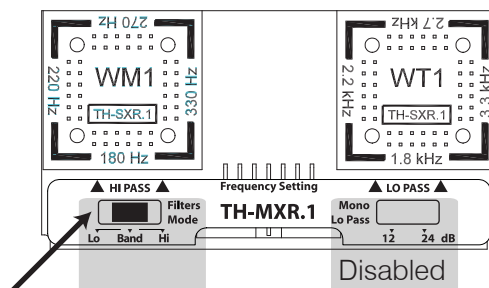

Classic domain



Electronic Crossover

TH in Mono Mode

When the amplifier is set up in a mono configuration, it is possible to set the crossover slope at 12 or 24 dB/Oct.
 - The TH-MXR.1 board must be inserted;
 - You need to operate on the ASC specific Setup Amplifier step. (See page 51).
 Through the Status Monitor it is possible to check anytime the presence of the filter as well as the set slope.

Setup Xover Slope 12 dB (default configuration)

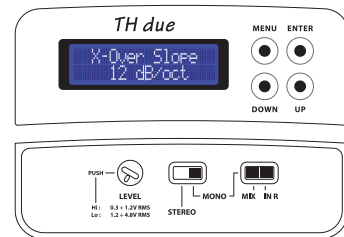

HI-PASS

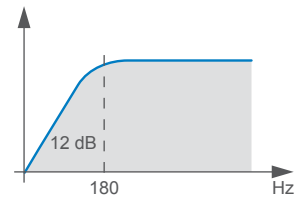
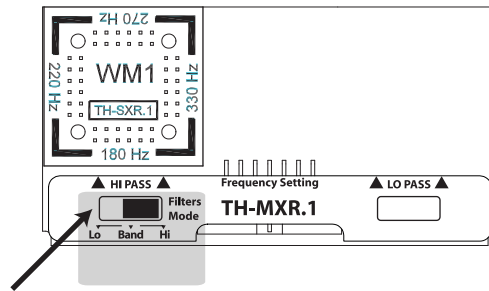

LO-PASS

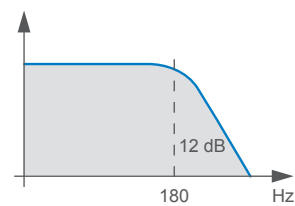
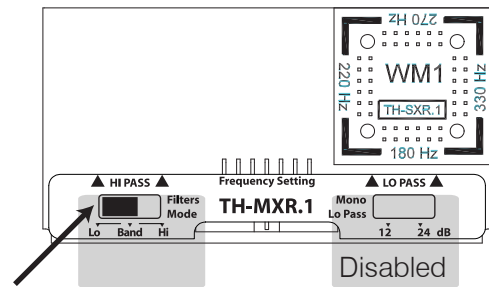

BANDPASS

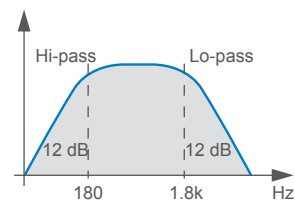
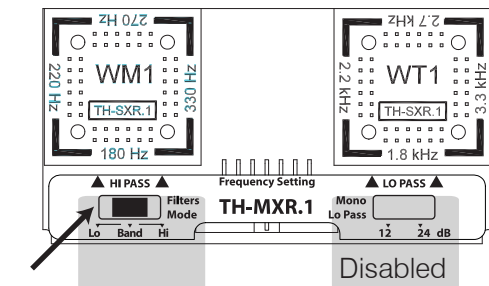



Electronic Crossover

TH in Mono Mode

When the amplifier is set up in a mono configuration, and ASC is set at 24 dB Oct., it is anyway possible to set the crossover Low-pass at 12 or 24 dB Oct.

- The TH-MXR.1 board must be inserted;
- You need to operate on the TH-MXR.1 switch. Through the Status Monitor it is possible to check anytime the presence of the filter as well as the set slope.

Setup Lo-pass Xover Slope 24 dB

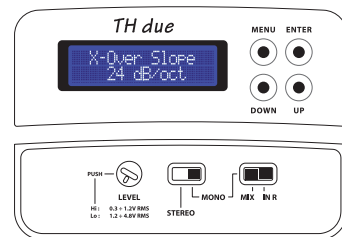

HI-PASS

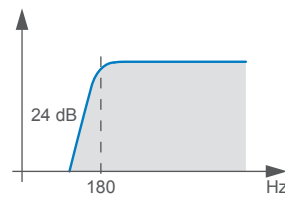
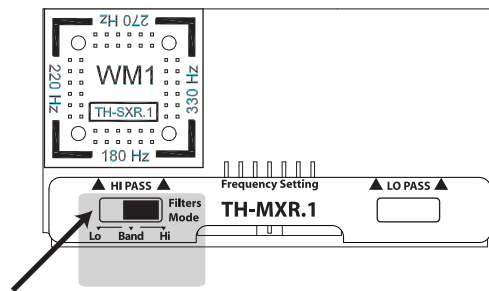

LO-PASS

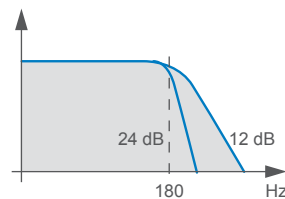
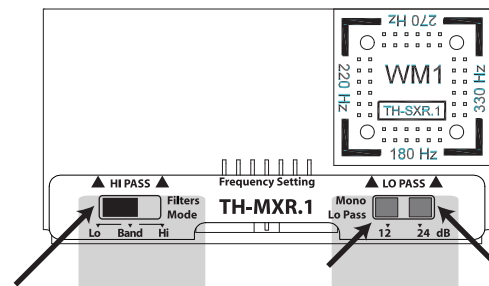

BANDPASS

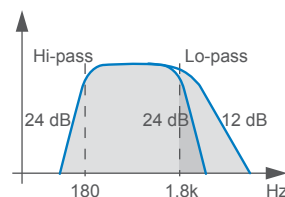
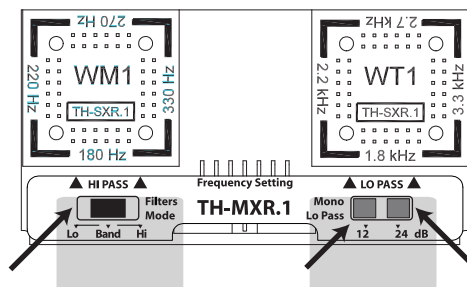



Electronic Crossover

How to insert - TH in Stereo Mode

Not inserted module
(default configuration)

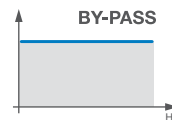
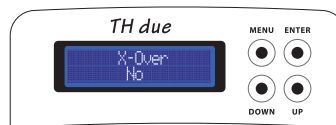
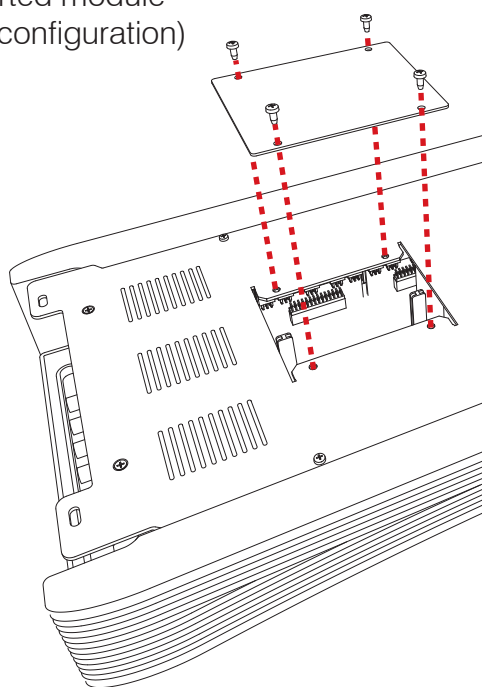

You can verify the crossover presence by checking the ASC Status Monitor. See page 58

TH in Stereo mode

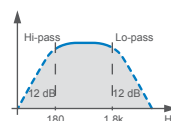
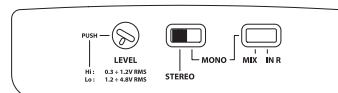
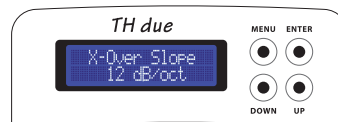
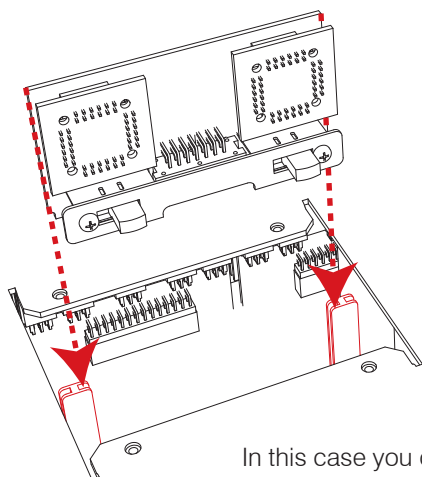

In this case you can verify both presence and slope of the crossover by checking the ASC Status Monitor, however it is not possible to modify its slope. See page 58.



Example: Two Way, mono configuration, TH amplifier Analog Input

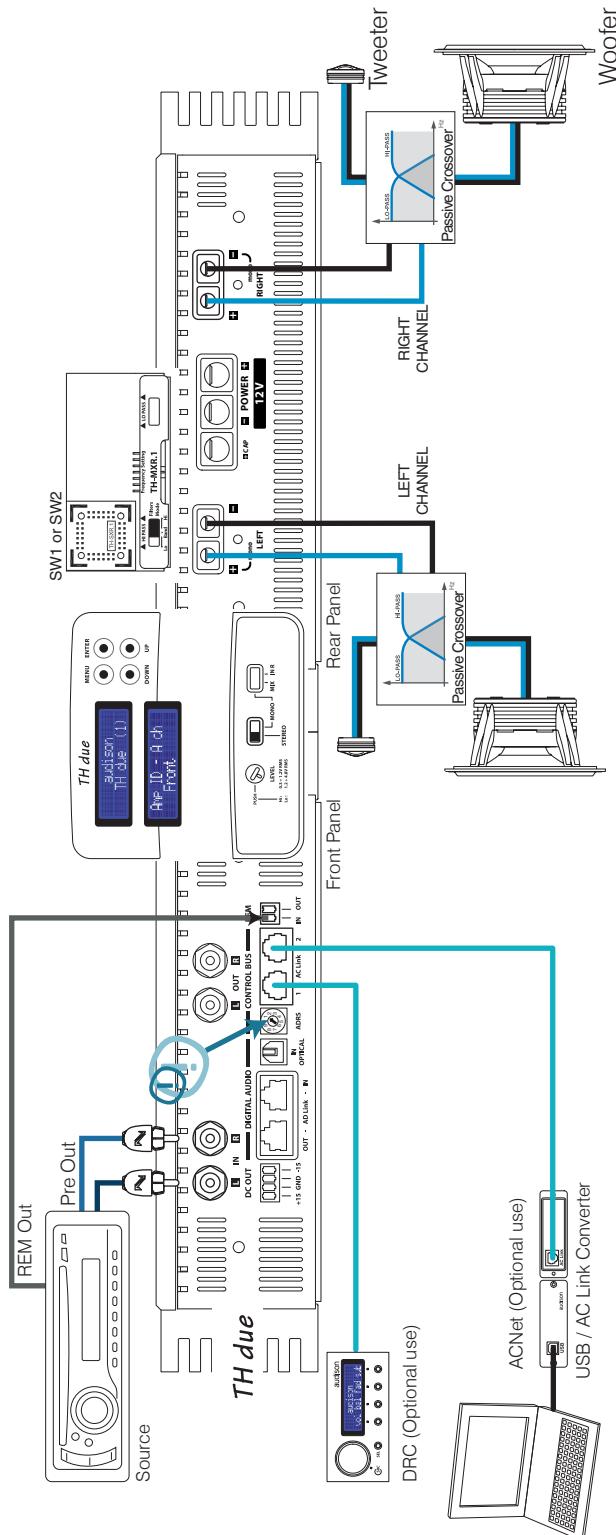

In order to build a Standard System you have to:

- 1- Insert the TH-MXR.1 board with its relative filter module (if required);
- 2- Connect power supply;
- 3- Connect the speaker system;
- 4- Connect signal inputs and remote turn on;
- 5- Select stereo mode on the Input Controls Panel;
- 6- Adjust sensitivity on the Input Controls Panel "LEVEL";

In order to add DRC to the System you also need to:

- 7- Set ADRS on the Front Panel (in position 1 for instance);
- 8- Set Amp ID (on FRONT for instance) in the ASC Setup Amplifier; this way DRC will be enabled to adjust general Volume, Balance and Fader.

In order to adjust the system through the ACNet:

On this system the steps 1, 2, 3, 4, 5 and 7 need to be performed.

The Software will temporarily bypass the DRC functionality in order to manage in a more direct and easier way all of the amplifier functions during the adjustment and modifying phases, including input sensitivity adjustment along with peak detector.

REMARK:

Into the amplifier ASC, the Dual Power and Runtime Monitor functions will anyway stay active (by default) and ready to change it directly (see page 52 and following pages).



Example: Two Way + bi-amplified Sub, TH amplifier Analog Input

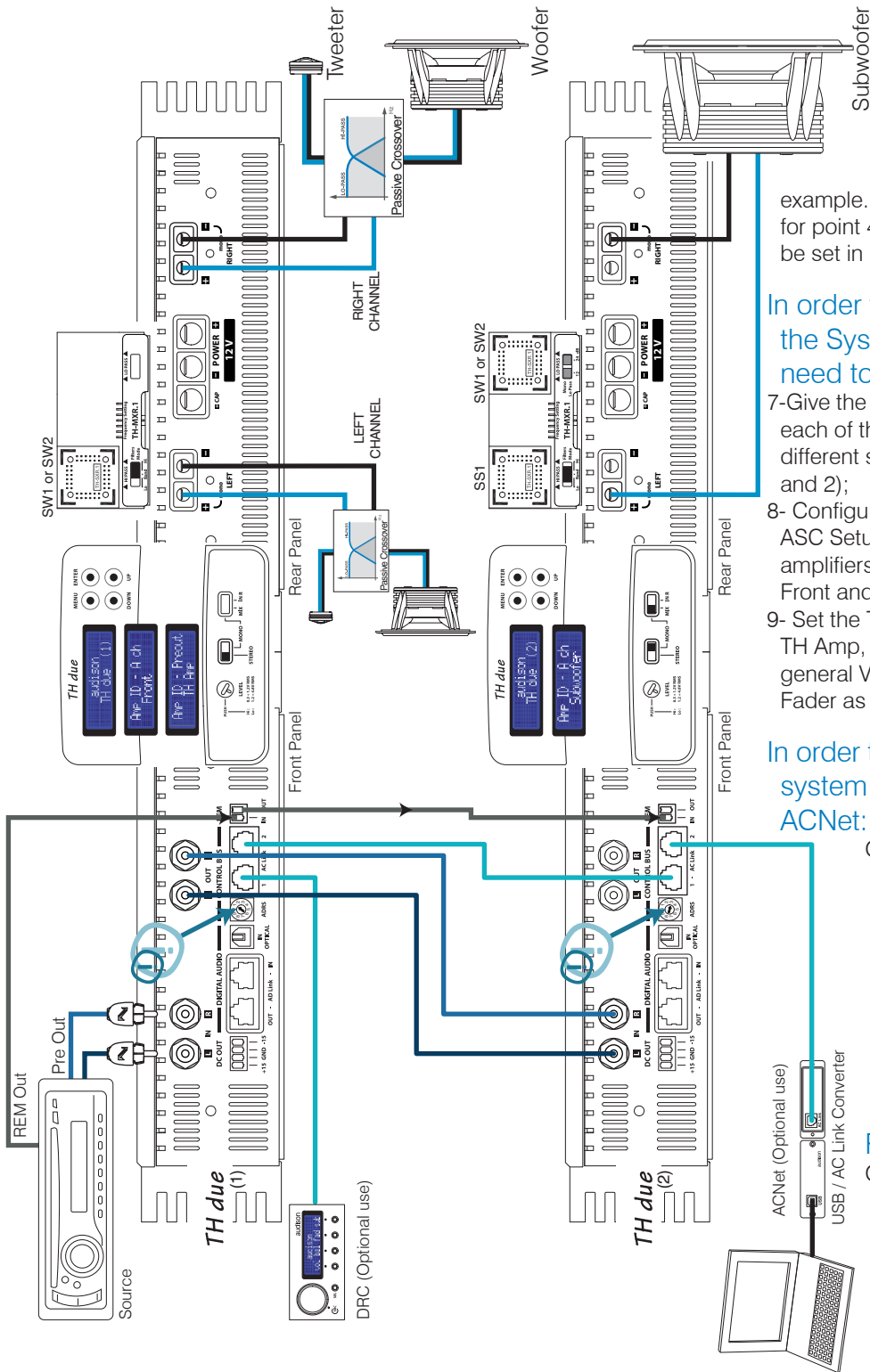

In order to build a Standard System:
You have to follow same steps as per the above

example. The only difference is for point 4, where TH (2) has to be set in Mono configuration;

In order to add DRC to the System you also need to:

- 7-Give the Front Panel ADRS of each of the two amplifiers a different setting (Example: 1 and 2);
- 8- Configure the Amp ID on the ASC Setup Amplifier of the two amplifiers by setting TH (1) as Front and TH (2) as Sub;
- 9- Set the TH (1) ID Preout as TH Amp, to let DRC adjust general Volume, Balance, Fader as well as Sub Volume.

In order to adjust the system through the ACNet:

Once the steps 1, 2, 3, 4, 5 and 7 have been performed, the Software will temporarily bypass the DRC in order to manage in a more direct and easier way all of the system functions.

REMARK:

On ASC Dual Power and Runtime Monitor will anyway stay active (by default) and ready for changes (see page 52 and following pages).

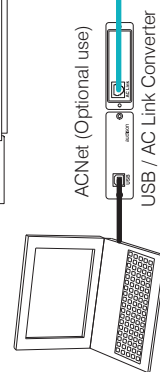



Example: Three Way + multi-amplified Sub, TH amplifier Analog Input

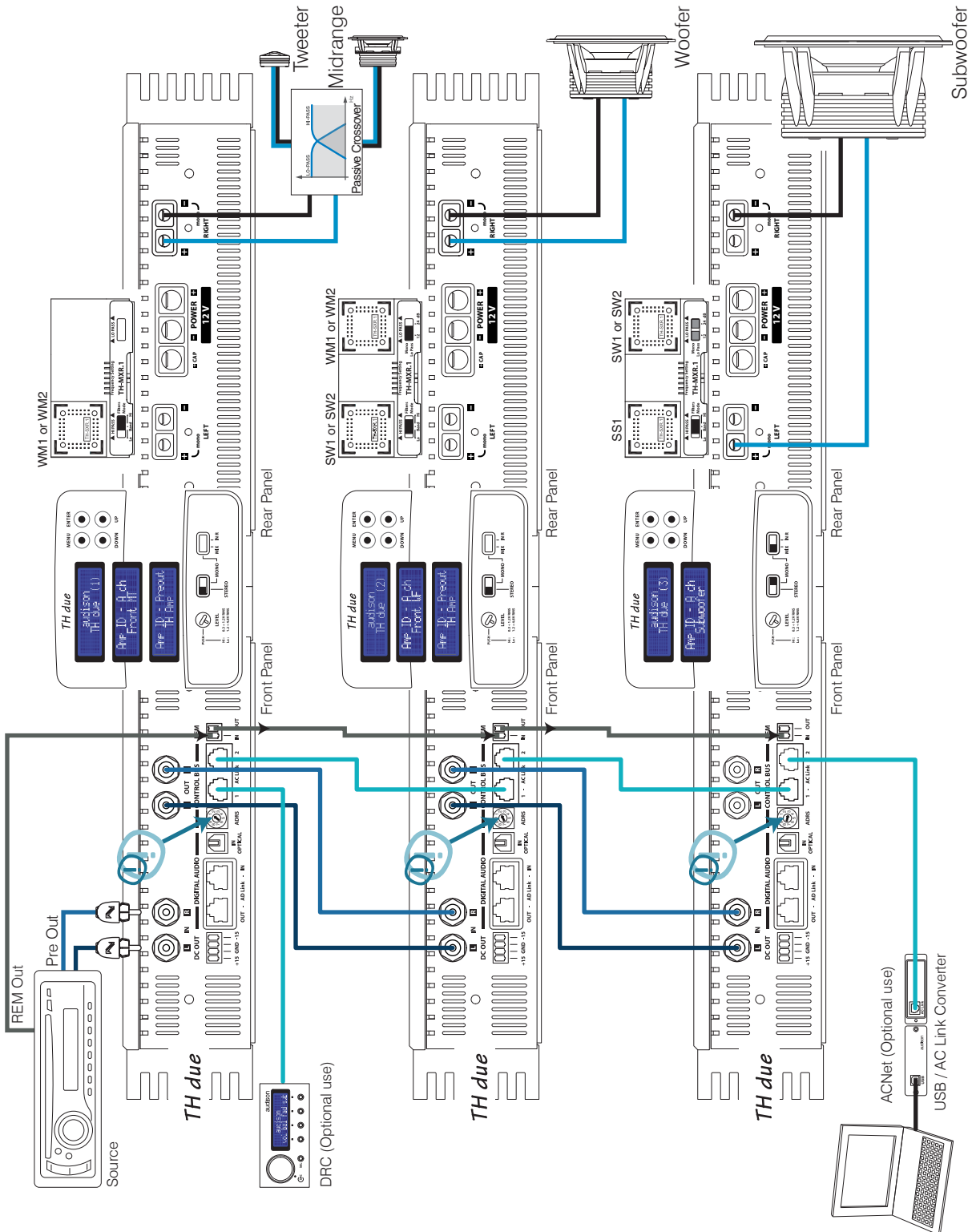



Example: Two Way + bi-amplified Sub, with and without TH amplifiers. Analog Input

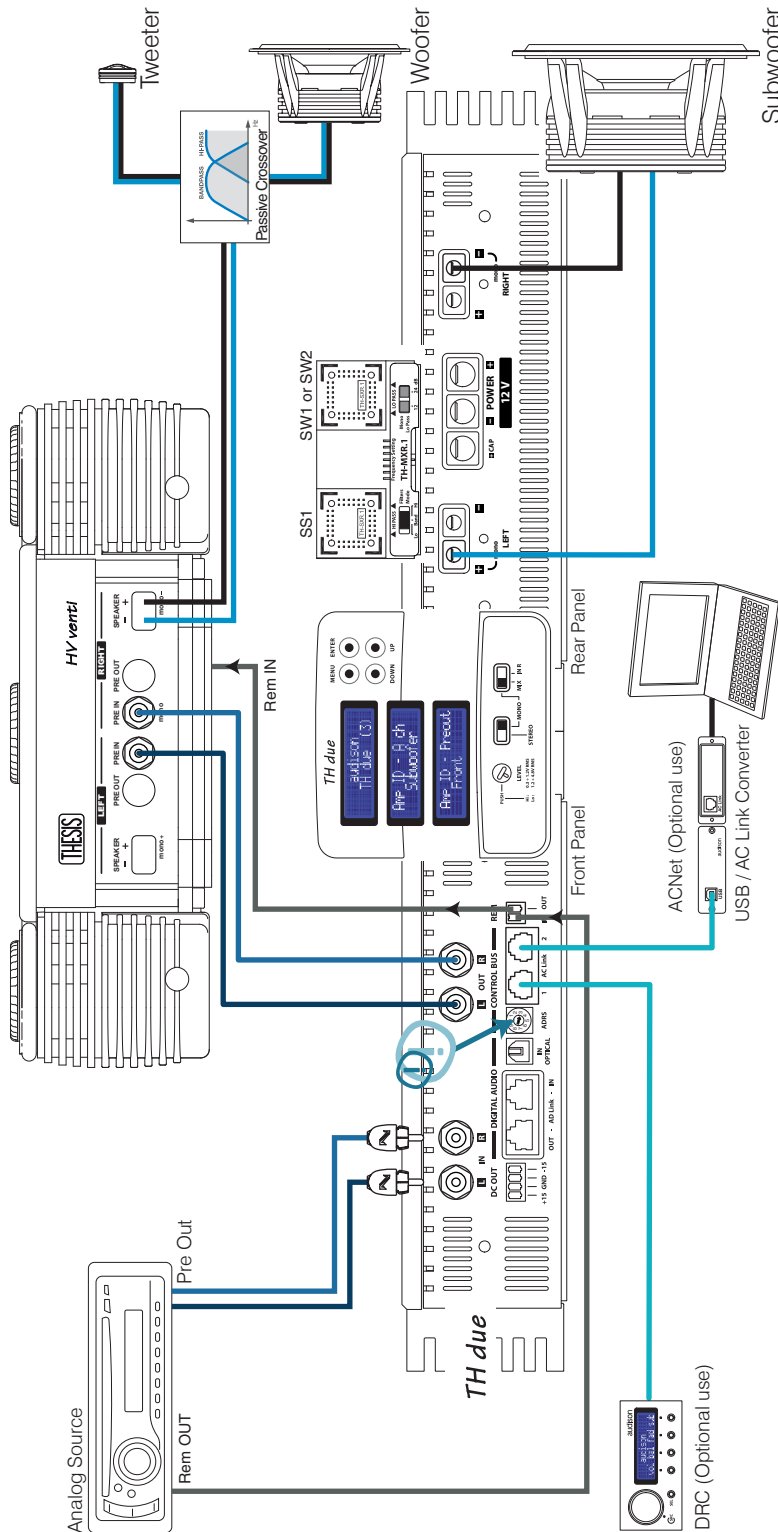

In order to build a Standard System:

You have to follow same steps as per the above example. The only difference is that TH has to be set up in Mono configuration. Also, it becomes the audio chain first amplifier, thus being able to manage the whole system;

In order to add DRC:

- 7- Set ADRS on the Front Panel (in position 1 for instance);
- 8- Set the Amp ID in the ASC Setup Amplifier as Sub.
- 9- Set the ID Preout as Front, to let DRC adjust general Volume, Balance, Fader as well as Sub Volume.

In order to adjust the system through the ACNet:

Once the above listed steps have been performed, the Software will temporarily bypass the DRC in order to manage in a more direct and easier way all of the system functions.

REMARK: On ASC Dual Power and Runtime Monitor will anyway stay active (by default) and ready for changes (see page 52 and following pages).



THESIS

ASC (AMPLIFIER STATUS CONTROLLER)

The TH amplifiers ASC unit is the operational interface, programmed to control all of the amplifier's functions. The user can interact with the microprocessor which, without interfering with the sound, will provide control for any possible adjustments. This manual section is especially thought for those who want to get the most of these amplifiers exclusive features.

Some functions are automatic and transparent to the user, others require support during the installing, adjusting or modifying phase. By accessing the ASC a set of menus will show, offering specific entries which the user can operate on:

- Setup Amplifier:

Main Input: the user can decide what kind of source the amplifier has to drive;

Amp ID: the user can name the amplifier identifying the function the amplifier performs inside the system;

ID Preout: the user can name the pre-amplified section so it is possible to manage it inside the system;

X-Over Slope: the user can select the Low-bass filter slope (only in Mono mode);

Dual Power: the user can choose the sound quality and the power the amplifier has to work at;

- Status Monitor:

the user can monitor the amplifier working status;

- Runtime Monitor:

the user can select it on the Display to intermittently have information on the amplifier status shown.

Some of these functions need a remote control communicating with the microprocessor. Inside this manual, where necessary, the presence of the DRC (Digital Remote Control) is underlined. The DRC also adds some specific functions which you can read on their relative section from page 61 on.

INPUTS AND PRE-AMPLIFIER

The TH amplifiers combine an analog and digital section in one device; keeping the two sections on separate PCBs, although mounted within the same sub chassis.

Each amplifier features a state-of-the-art digital encoding section as well as a 24 bit 192 kHz converter. The S/PDIF optical input accepts PCM stereo signals; also, the innovation consists in the fact the TH amplifier can be driven in digital directly and, as a consequence, the whole system too, if a system in multi-amplification configuration with the re-launch of this digital signal to other Thesis TH amplifiers through the AD Link system (Audison Digital Link). Each amplifier independently takes care of the D/A conversion. While in the Digital Input mode the DRC needs to be connected, so it works as an actual general volume and source selector control, capable of repeating all the low frequency controls (Master Volume, Balance, Fader, Sub Volume).

The AD Link connectors on the TH input panel can receive the digital signal from sources or multi-channel processors featuring the afore-mentioned outputs (Audison Bit One) and re-launching the digital signal to the amplifiers chain through a Cat.5 certified shielded cable equipped with an RJ45 connector (provided).

In the following pages of this manual we will explain how to perform the amplifier setup and how to connect it in all THESIS or mixed chains.

ASC - Amplifier Status Controller

Functions Description

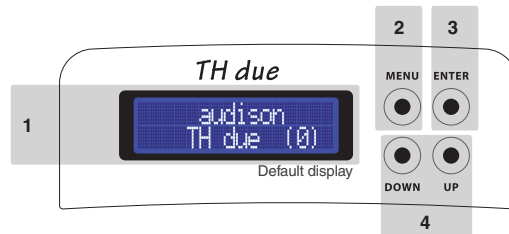

- 1 • **TH due STATUS DISPLAY:** it is the visual element of the ASC system, a back-lit two line 32 character LCD display; While working, it can relate all of the configuration parameters memorised by the amplifier during the installation, as well as the operational status of the amplifier.
The following pages address all the messages and information which from time to time the display can show. In case of protection intervention, the state of protection is permanently displayed, until the problem is resolved or until the amplifier is reset;
- 2 • **MENU:** this switch enables the ASC and shows the first available entry. Each time this switch is pushed while the amplifier is normally working, the ASC displays the first available entry, not the last you worked on. No matter which step of the management you are at, if you push the MENU button, you exit the ASC management and you are automatically taken back to the first display screen (Default display) without saving any changes.
Remark: No matter which step you are at of the management software, if you don't operate on the switches for 5 seconds, the ASC automatically goes back to the first display screen (Default display) without saving any changes.
- 3 • **ENTER:** this switch is to:
 - confirm the selected entry,
 - store it in the memory,
 - move to the following menu entry.
 The ASC performs these three activities automatically. If you modify the menu entry you are working on and then you push "enter", the display will show:



then the display will show the next entry. The changes will only be made once ENTER is pushed.

- 4 • **UP - DOWN:** through these switches the user can browse through the entries available inside the different menus. According to the function you are checking, they allow you to modify your choice which, then, will have to be confirmed by pushing ENTER.



ASC - Amplifier Status Controller

Setup Amplifier: Main Input

The first step to set the amplifier up is to select the main input the TH will use to get the signal. As soon as you turn the amplifier on, the PRE analog input is selected by default. By changing this entry the user can also take advantage of the other operational modes. From next time you turn the TH on, it will use the last selected entry.

If another input is used, the DRC is required. In that case, if for any reasons it is disconnected, all the setup settings and low level controls will reset back to the default settings, unless the DRC is re-connected, in which case they restore. (See page 36)

How to change: Main Input (Stereo or Mono Mode)

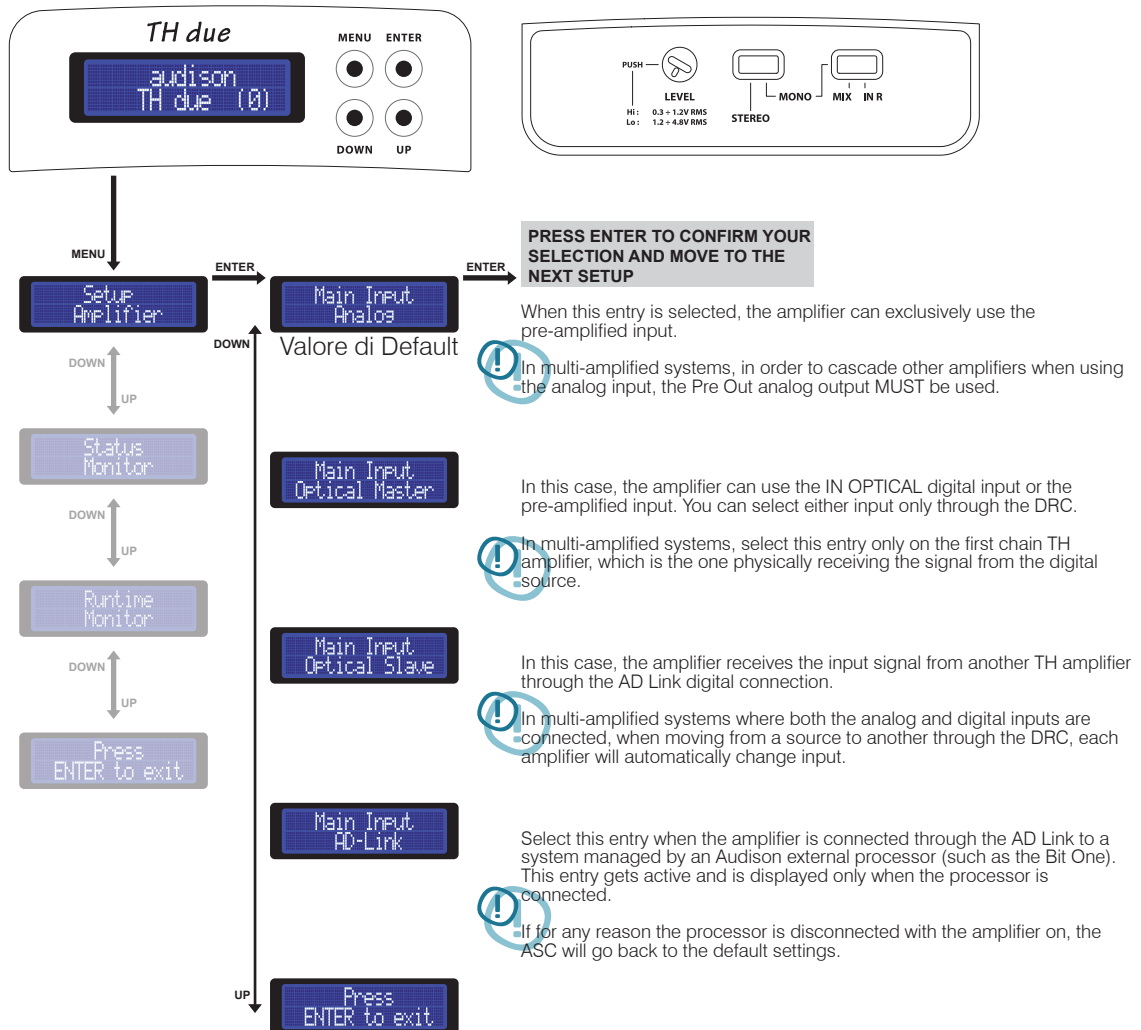

Digital Inputs

How to adjust the volume control and input selector using a digital source

In the following pages you will find examples of how to connect the TH to a system driven by sources using the digital input. In order to use the TH IN OPTICAL digital input and therefore its D/A internal converter the DRC Digital Remote Control MUST be connected to the TH amplifier.

The DRC will perform the function of selecting the source by selecting between Analog Input and Optical Input, thus allowing the control of Main Volume, Subwoofer Volume, Balance and Fader.

If the last setup working conditions are no more valid, that is if you disconnect the DRC and you had changed the default conditions, the ASC will automatically go back to use the PRE Analog Input. In this case Fader and Balance will go back to central position, while general Volume and Sub Volume will go back to 0 dB (maximum value). The TH display will show the following information:

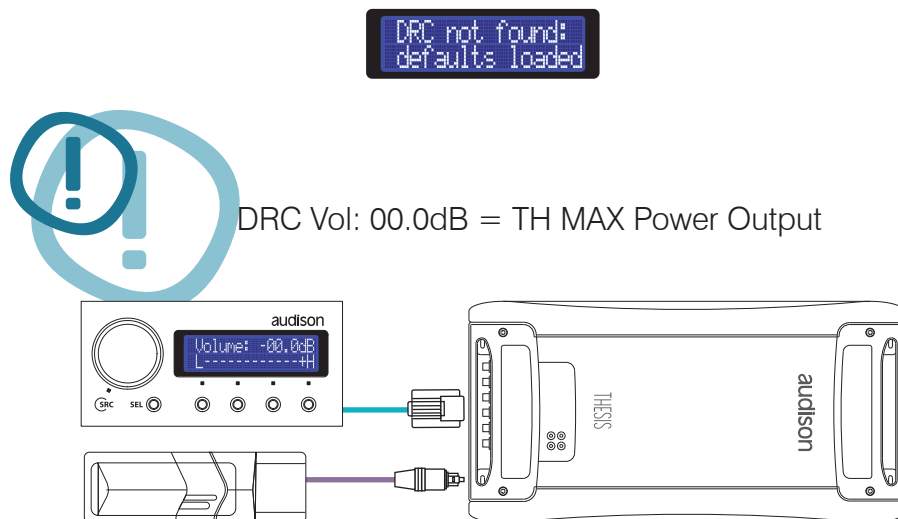

Warning:

When using the optical digital input you have to use the DRC as main volume control. If the DRC volume control is at 0 dB it equals to the amplifier undistorted maximum output power.

To check all the functions and the DRC connection, see pages 61 ÷ 63

Front Panel

How to achieve same output volume level using an analog source (with its own volume control) and a digital source

Once you have adjusted the system, therefore once the amplifiers input sensitivity has been adjusted, you can adjust the digital source volume level so that when selecting the analog or the digital source no difference in sound is perceptible while listening. Once performed this adjustment, we would recommend that you use the DRC volume control as general volume control.

- 1) On the DRC select the source: Optical Input
- 2) On the DRC adjust volume until you can read -30.0 dB
- 3) Insert the Test CD provided with the amplifier into the source connected to the digital input
- 4) Select track # 05 (sinusoidal signal 1 kHz / 0 dB)
- 5) Using a multimeter (True RMS) measure the voltage on the speaker terminals
- 6) On the DRC select the source: Analog Input
- 7) Do not change the set volume (-30.0 dB)
- 8) Insert the Test CD provided with the amplifier into the source connected to the digital input
- 9) Select track # 05 (sinusoidal signal 1 kHz / 0 dB)
- 10) Adjust the volume of the source connected to the analog input until, using a multimeter (True RMS),
- 11) you measure the same voltage on the speaker terminals
- 12) Use the DRC as main volume control

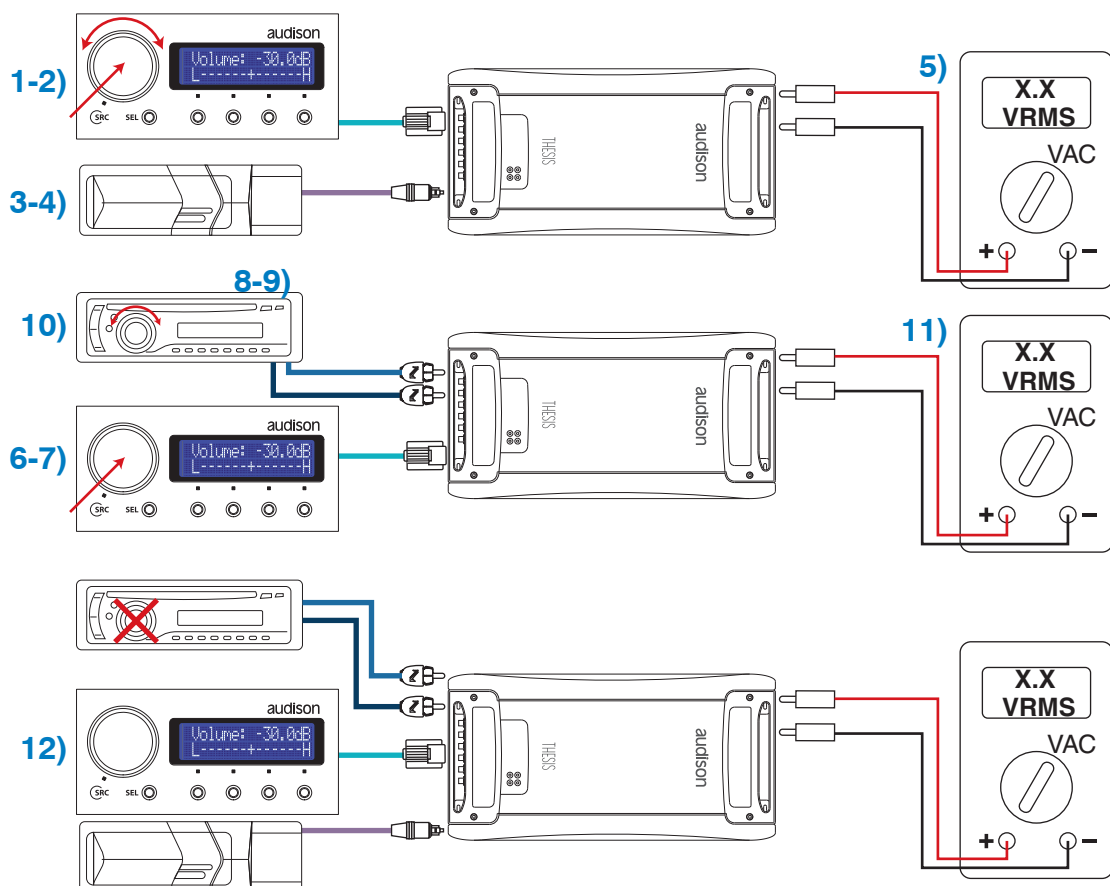



Front Panel

How to connect a source through the optical digital input in a system featuring more than one TH amplifier

TH configured in Stereo mode

Input: Digital Optical S/P DIF
Pre Out: Digital AD Link (Repeats the IN OPTICAL signal)
Power Output: Stereo

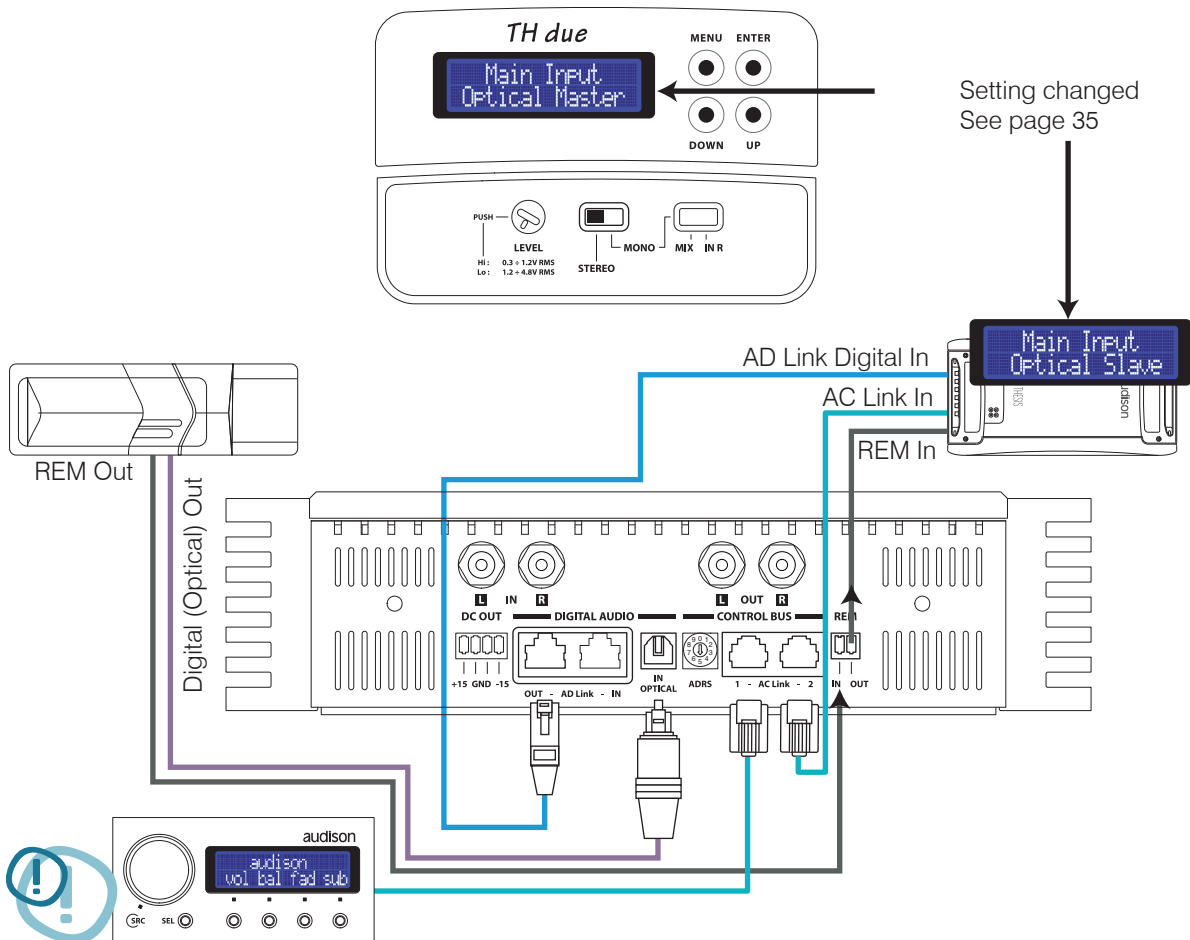

Setting changed
See page 35



In this case the DRC is REQUIRED to:
 - Adjust the general volume
 - Select the optical input

PRE OUT:
anyway available, see page 39

Digital domain



Front Panel

How to connect a source through an optical digital input in a system featuring other non-TH amplifiers

TH configured in Stereo mode

Input: Digital Optical S/P DIF
Pre Out: Stereo Analog (R and L Ch of Digital Input)
Power Output: Stereo

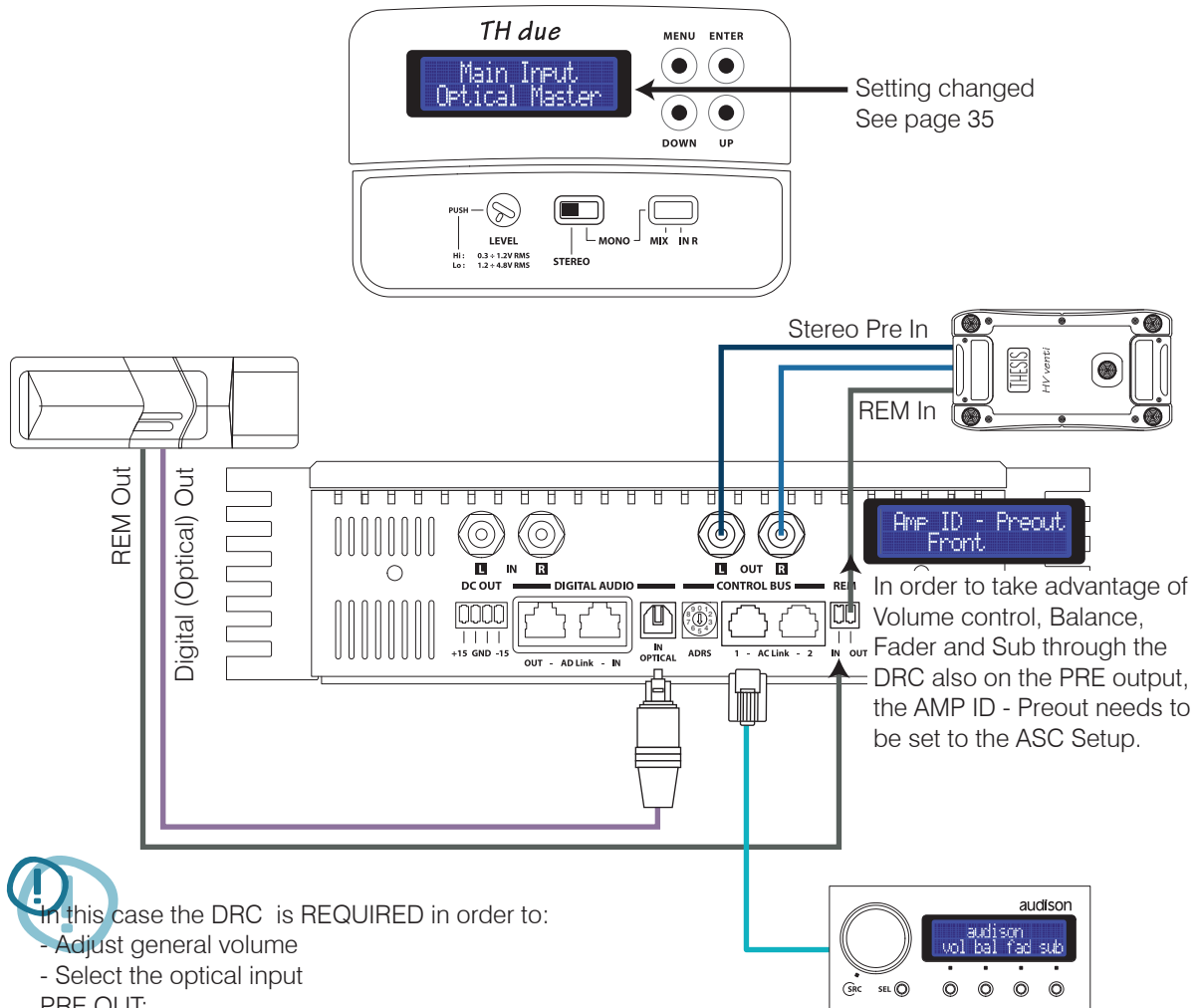

Digital domain



Front Panel

How to connect a source through an optical digital input in a system featuring more than one TH amplifier

TH configured in Mono MIX L+R mode

Input: Digital Optical S/P DIF
Pre Out: Digital AD Link (Repeats the IN OPTICAL signal)
Power Output: Mono MIX L+R

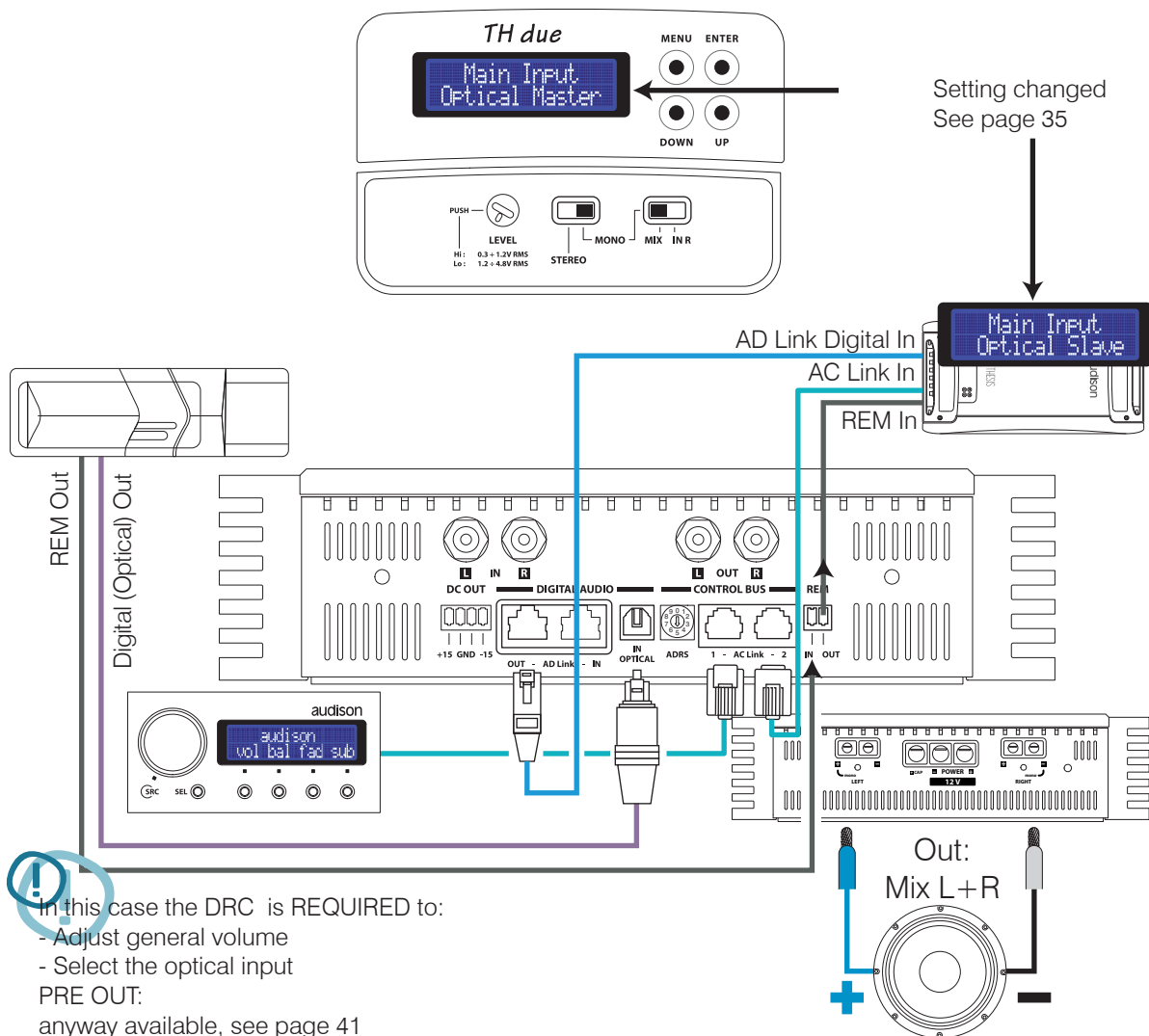

Digital domain



Front Panel

How to connect a source through the optical digital input in a system featuring other non-TH amplifiers

TH configured in Mono MIX L+R mode

Input: Digital Optical S/P DIF
Pre Out: Stereo Analog (R and L Ch of Digital Input)
Power Output: Mono MIX L+R

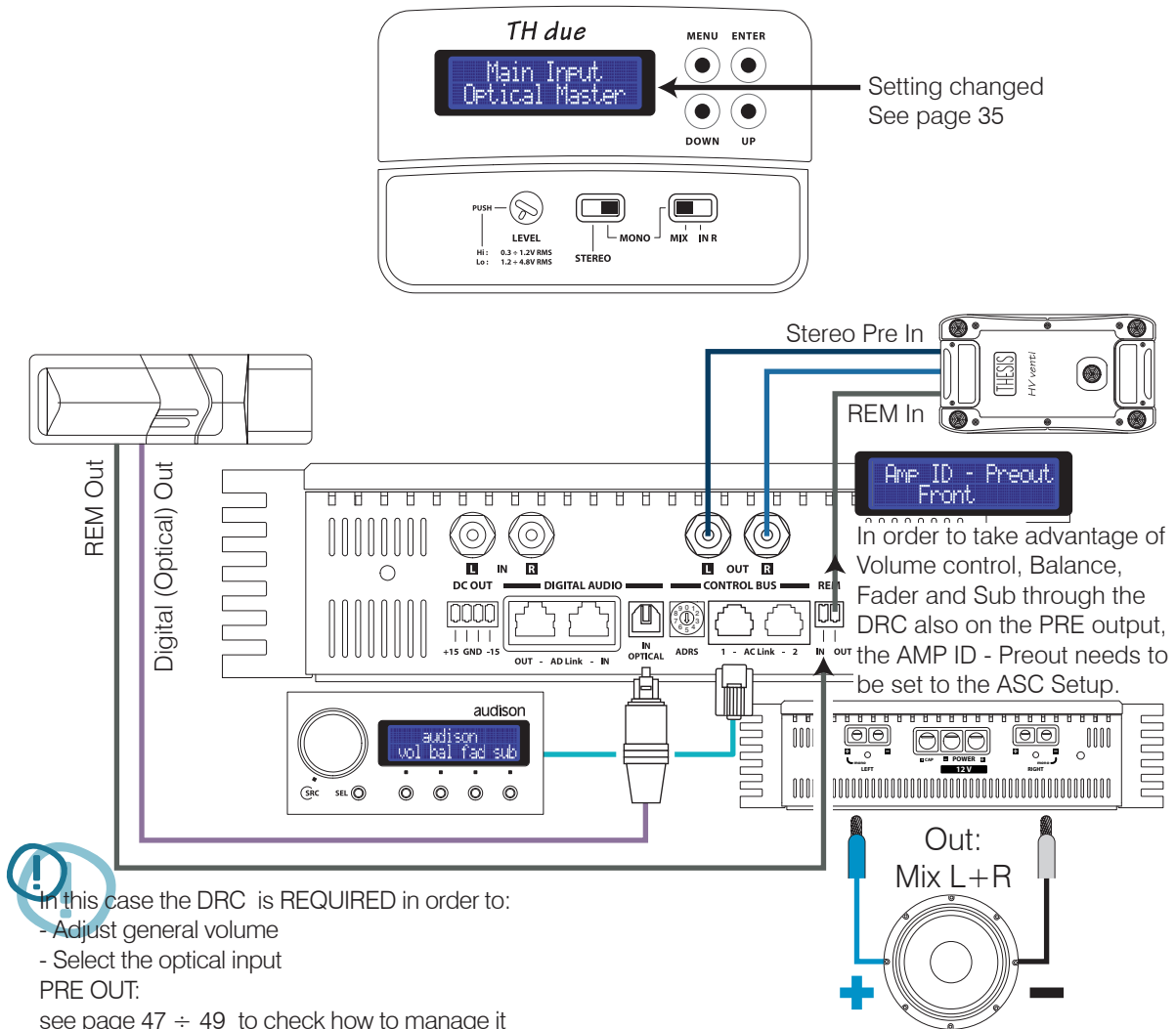

Digital domain



Front Panel

How to connect an analog and a digital source in a system featuring more than one TH amplifier

TH configured in Stereo mode

Input: Analog/Digital Optical S/P DIF
Pre Out: Analog/Digital AD Link
Power Output: Stereo

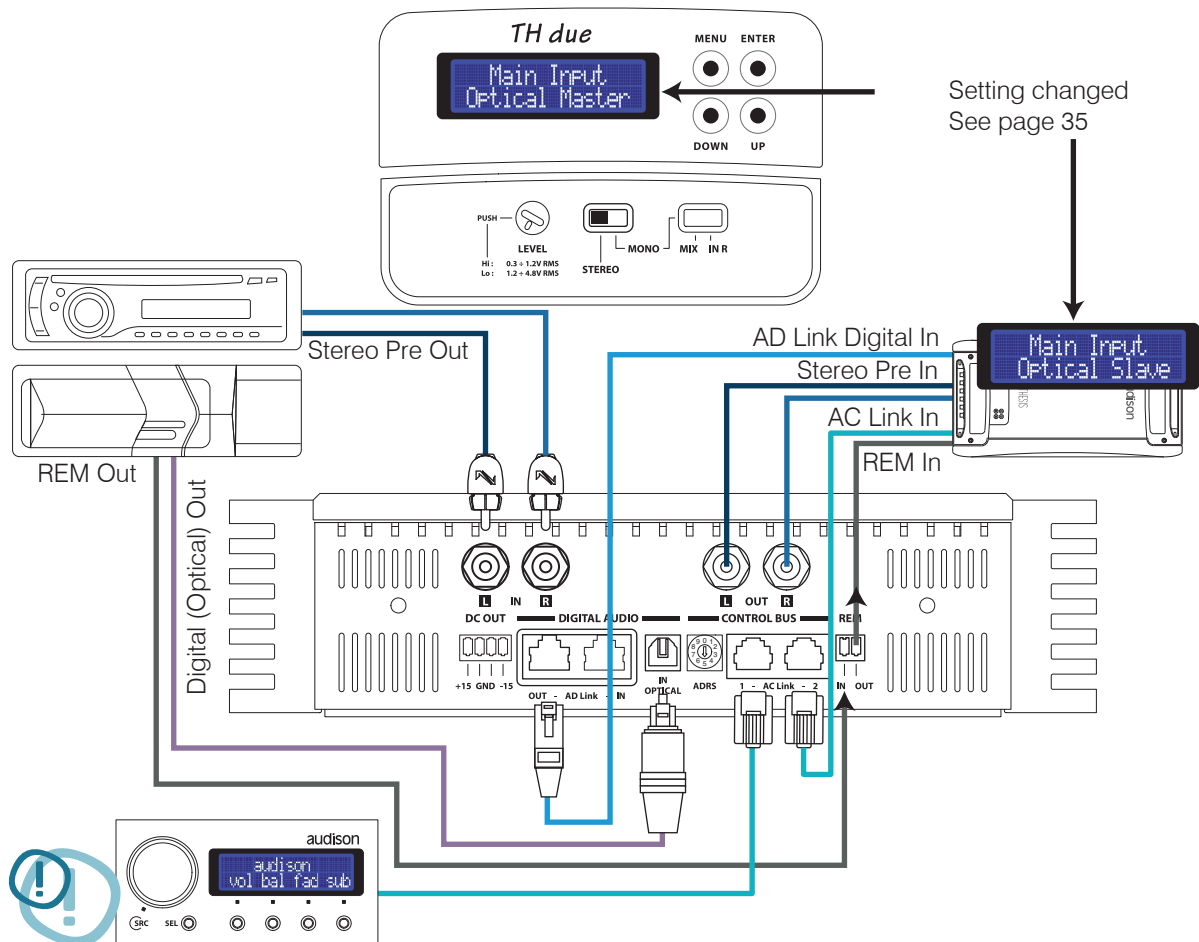

In this case the DRC is REQUIRED to:

- Adjust general volume
- Select the optical input

PRE OUT:
 anyway available, see page 34



Front Panel

How to connect an analog and a digital source in a system featuring other non-TH amplifiers

TH configured in Stereo mode

Input: Analog/Digital Optical S/P DIF
Pre Out: Stereo Analog
Power Output: Stereo

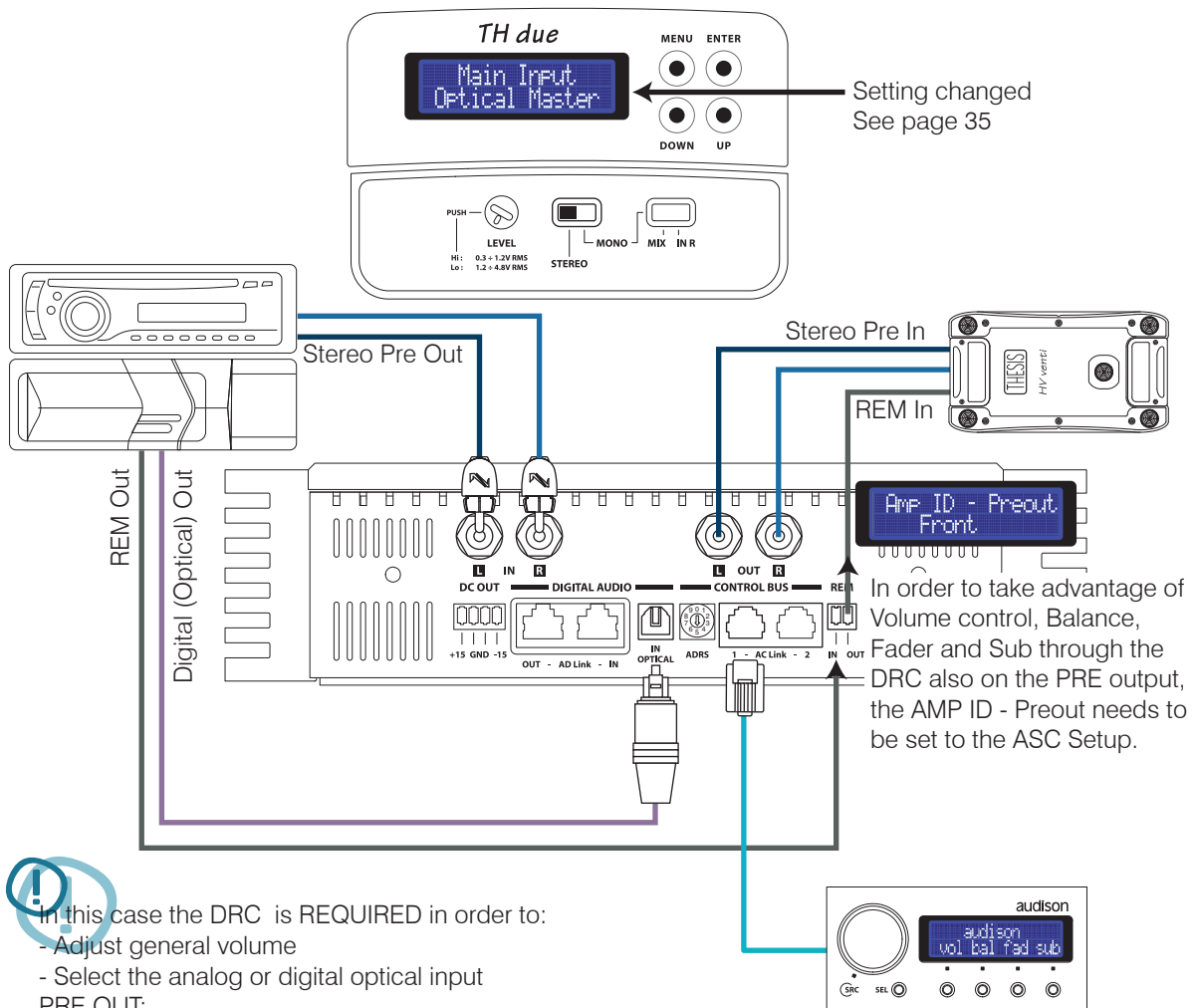

! In this case the DRC is REQUIRED in order to:

- Adjust general volume
- Select the analog or digital optical input

PRE OUT:
 see page 47 ÷ 49 to check how to manage it

Digital domain





Front Panel

How to connect an analog and digital source in a system featuring more than one TH amplifier

TH configured in Mono MIX L+R mode

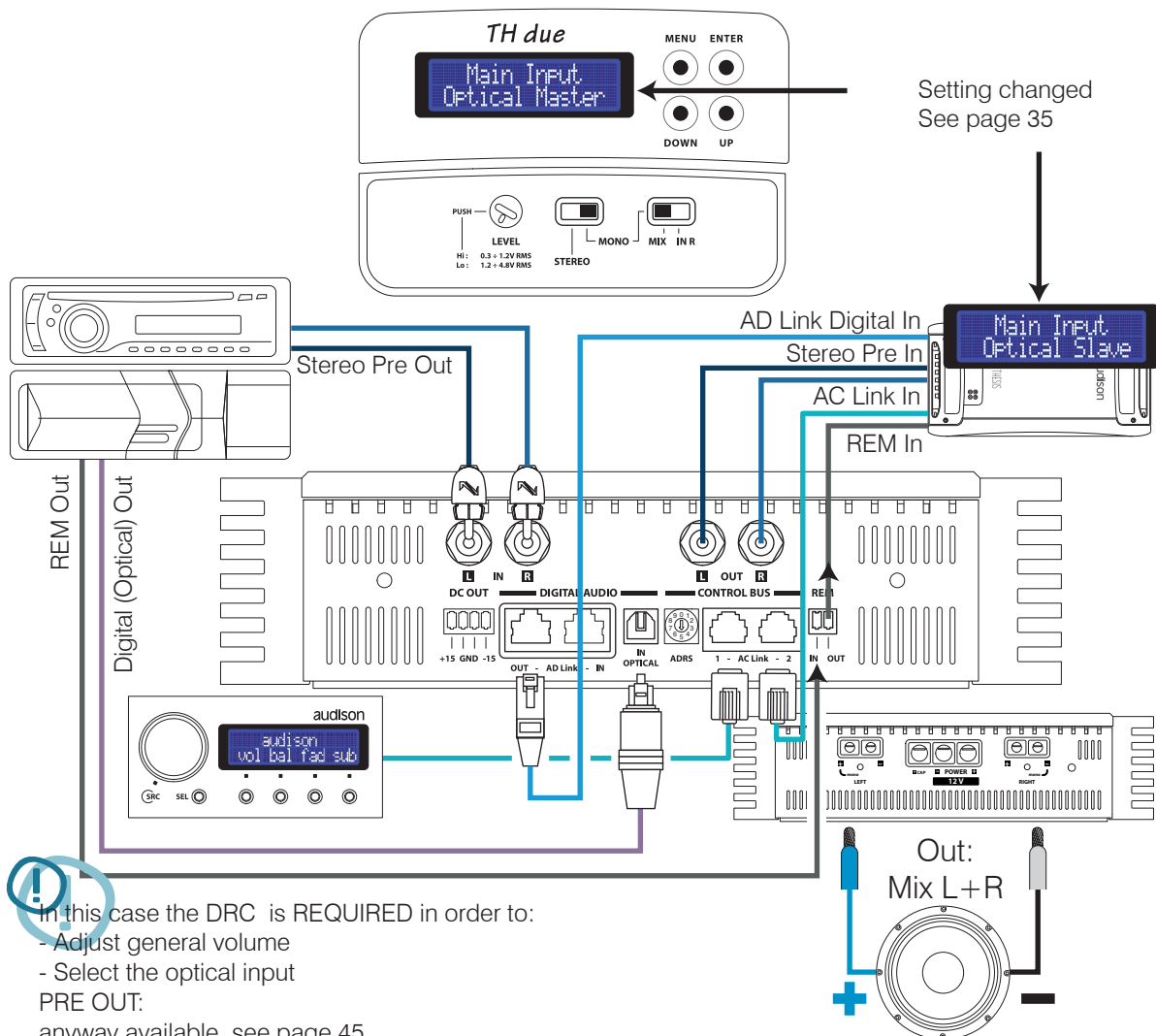
Input: Analog/Digital Optical S/P DIF
Pre Out: Analog/Digital AD Link
Power Output: Mono MIX L+R



 In this case the DRC is REQUIRED in order to:

- Adjust general volume
- Select the optical input

PRE OUT:
anyway available, see page 45

Digital domain



Front Panel

How to connect an analog and a digital source in a system featuring other non-TH amplifiers

TH configured in Mono MIX L+R mode

Input: Analog/Digital Optical S/P DIF
Pre Out: Stereo Analog
Power Output: Mono MIX L+R

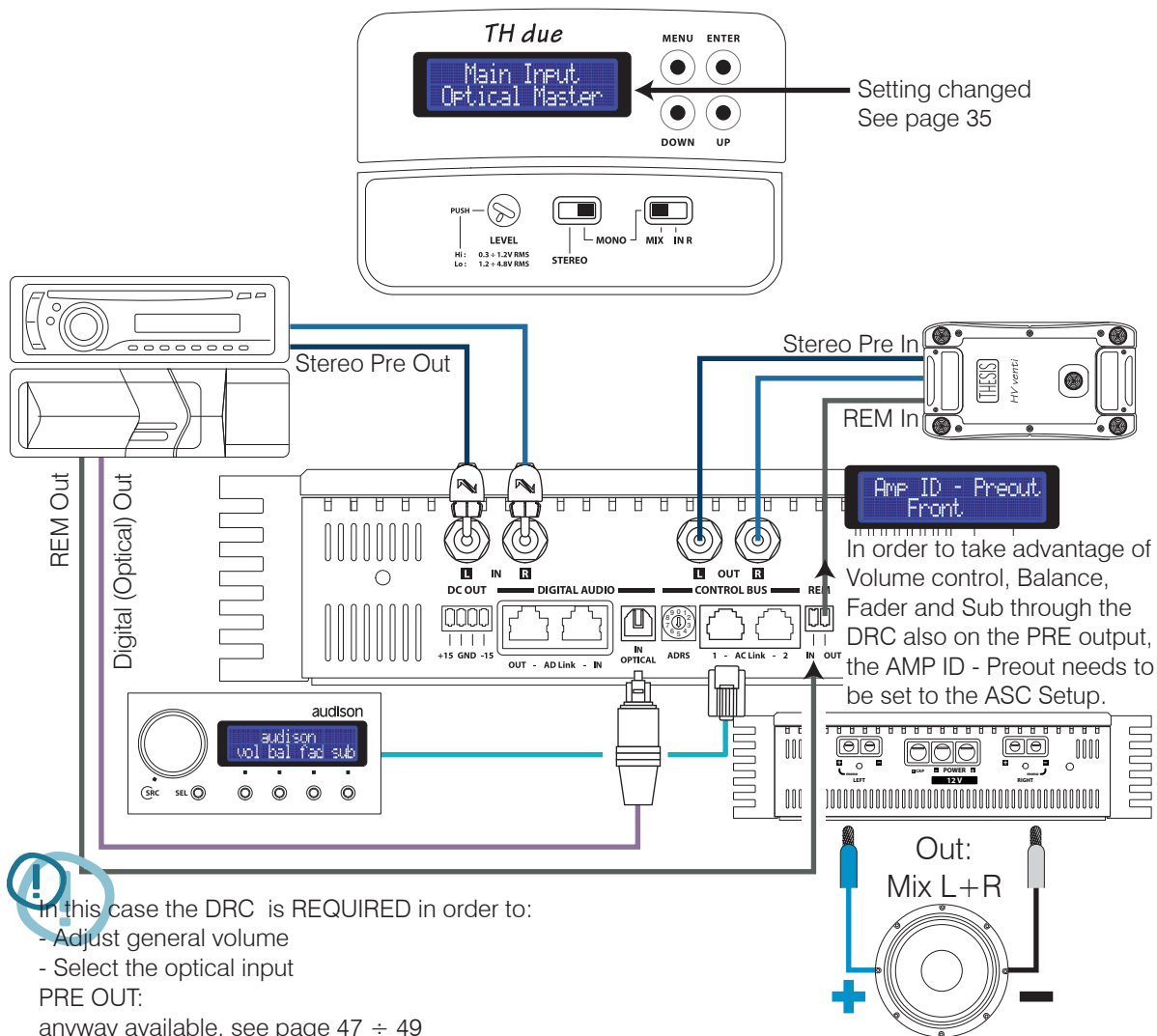

! In this case the DRC is REQUIRED in order to:

- Adjust general volume
- Select the optical input

PRE OUT:
anyway available, see page 47 ÷ 49

Digital domain



ASC - Amplifier Status Controller

Setup Amplifier: Amp ID

TH in Stereo mode

AMP ID stands for Amplifier IDentification. The AMP ID is a way to identify the task the amplifier performs inside the system. The AMP ID does not affect the electric functioning and does not act on the amplifier electronic crossover. The AMP ID is fundamental to adjust Volume, Balance, Fader as well as Sub Volume when the DRC is connected. The ASC recognises the function the amplifier has been given through the ID. By acting on the DRC and adjusting Volume, Balance, Fader as well as Sub Volume, as a consequence also the signal to the amplifiers will be managed.

Example:

If the AMP ID-Front is assigned to the TH amplifier, by operating on the DRC its general volume, as well as the right/left balance, will change. Also, by setting the Fader on Rear you will hear the volume diminishing; however, no change will be perceived if you operate on the DRC Sub volume.

Vice versa, if the AMP ID – Subwoofer is assigned to the TH amplifier, by operating on the DRC its general volume, more specifically the Sub volume, will change; however, no change will be perceived if you operate on the right/left balance or moving the Fader.



In order to avoid errors, you should assign the ID according to the speakers connected to the amplifier.

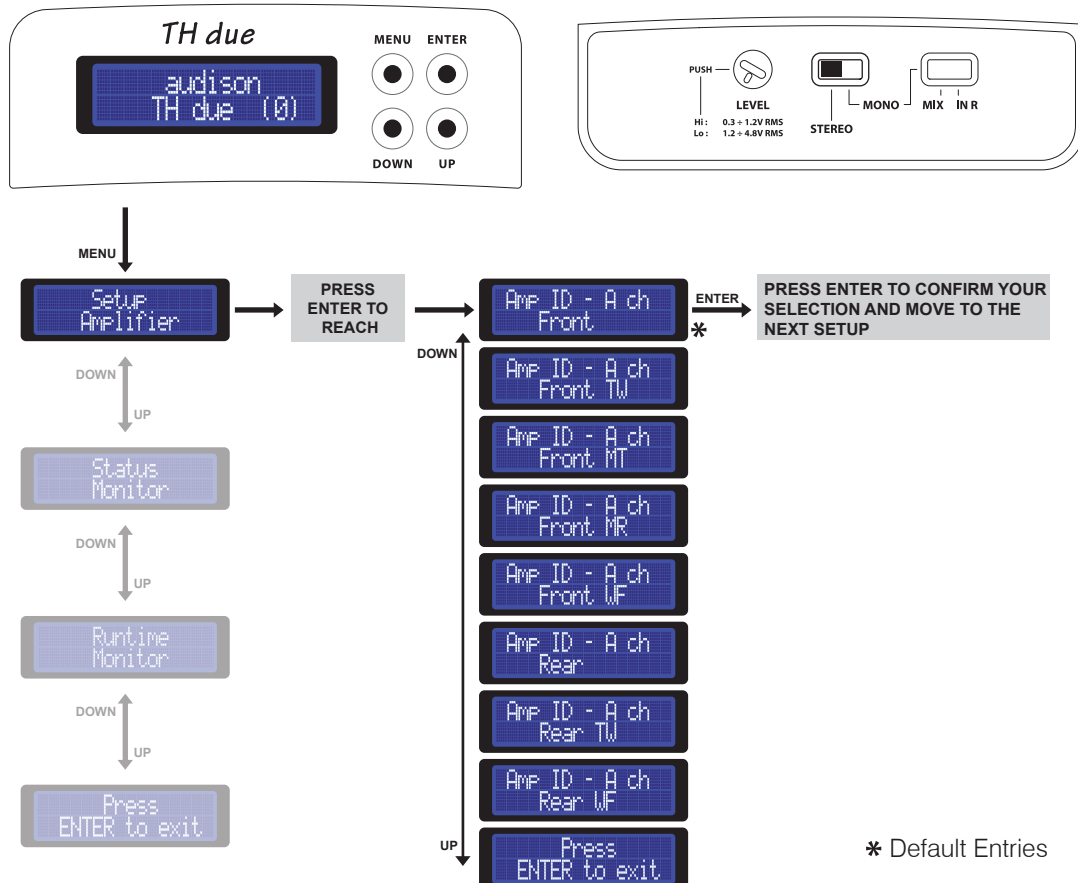

* Default Entries



ASC - Amplifier Status Controller

Setup Amplifier: Amp ID-Preout

TH in Stereo mode

The AMP ID can also be assigned to the PRE OUT output. This function is extremely useful in case the TH amplifier is added to a pre-existing system featuring not only TH amplifiers or if you want to add to the TH system a non-TH amplifier. This way you can anyway know the non-TH amplifier function as well as adjust its volume. The AMP ID - Preout provides the ability to expand the system endlessly, keeping the low level parameters management functions through the DRC.



As the AMP ID – Preout does not operate on the electronic crossover, it does not put in any filters on the output signal! The signal on the PRE OUT output will always be exactly the same as the one on the selected input.

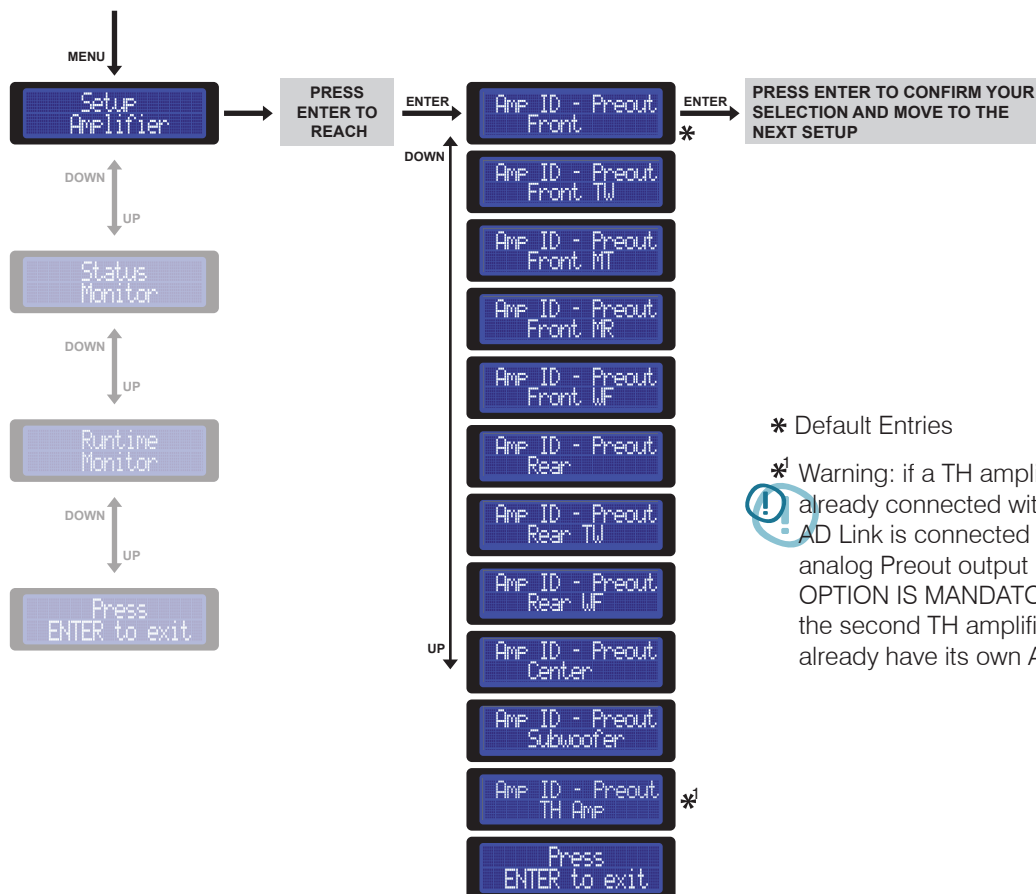
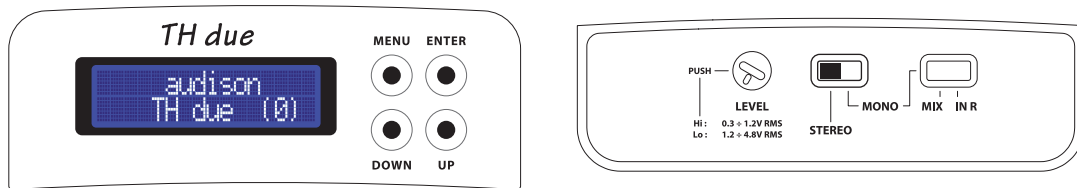

* Default Entries

*! Warning: if a TH amplifier already connected with the AD Link is connected to the analog Preout output, THIS OPTION IS MANDATORY, as the second TH amplifier will already have its own AMP ID.



ASC - Amplifier Status Controller

Setup Amplifier: Amp ID and ID-Preout

TH in Mono mode MIX L+R

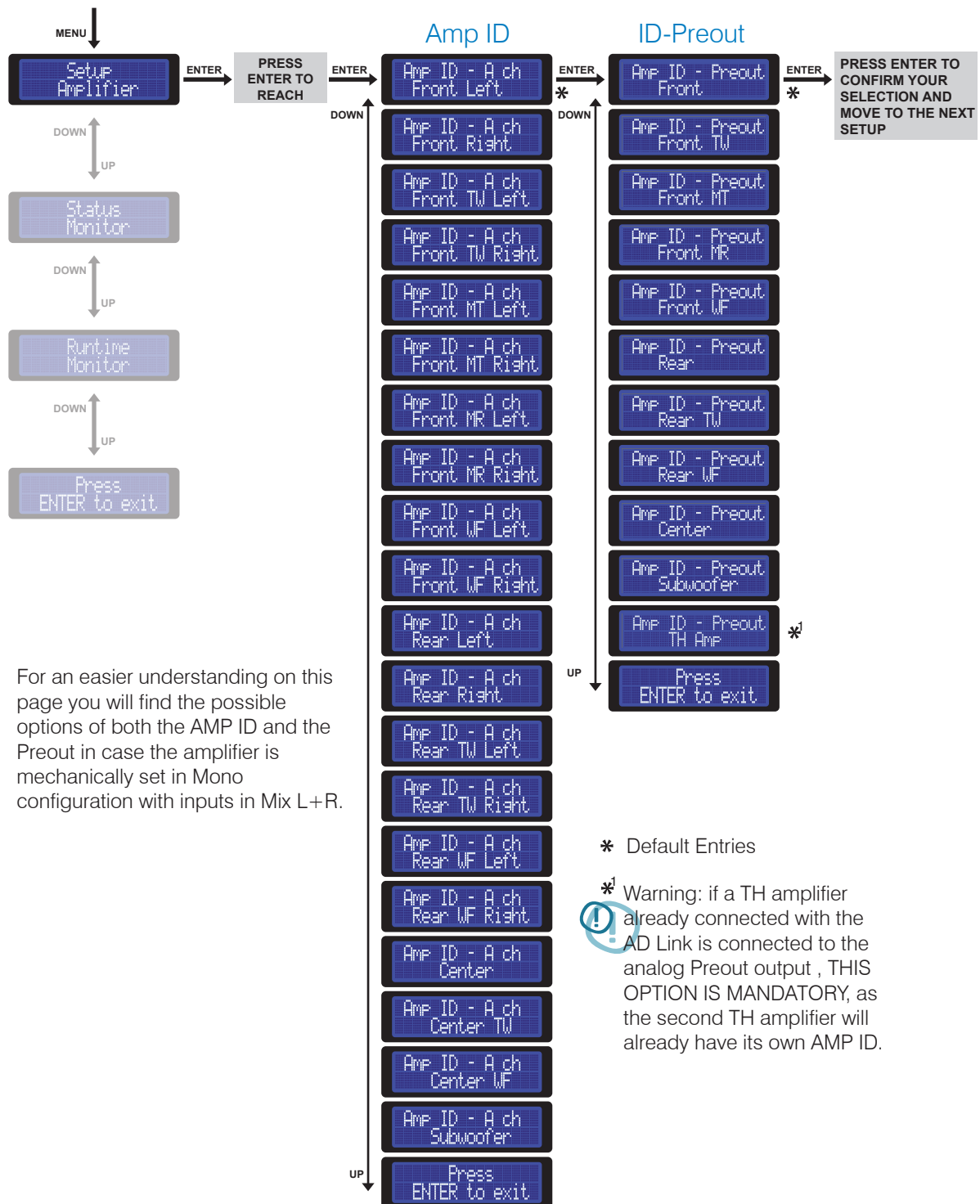

For an easier understanding on this page you will find the possible options of both the AMP ID and the Preout in case the amplifier is mechanically set in Mono configuration with inputs in Mix L+R.



ASC - Amplifier Status Controller

Setup Amplifier: Amp ID and ID-Preout TH in Mono mode IN R

By selecting an AMP ID entry which takes advantage of the amplifier for the left channel, you can assign one single entry dedicated to the left channel to the ID Preout. Vice versa, by selecting an AMP ID entry which takes advantage of the amplifier for the right channel, you can assign one single entry dedicated to the right channel to the ID Preout.



This dedicated setting is only valid using the analog input.

Example: if you use the amplifier for the left channel

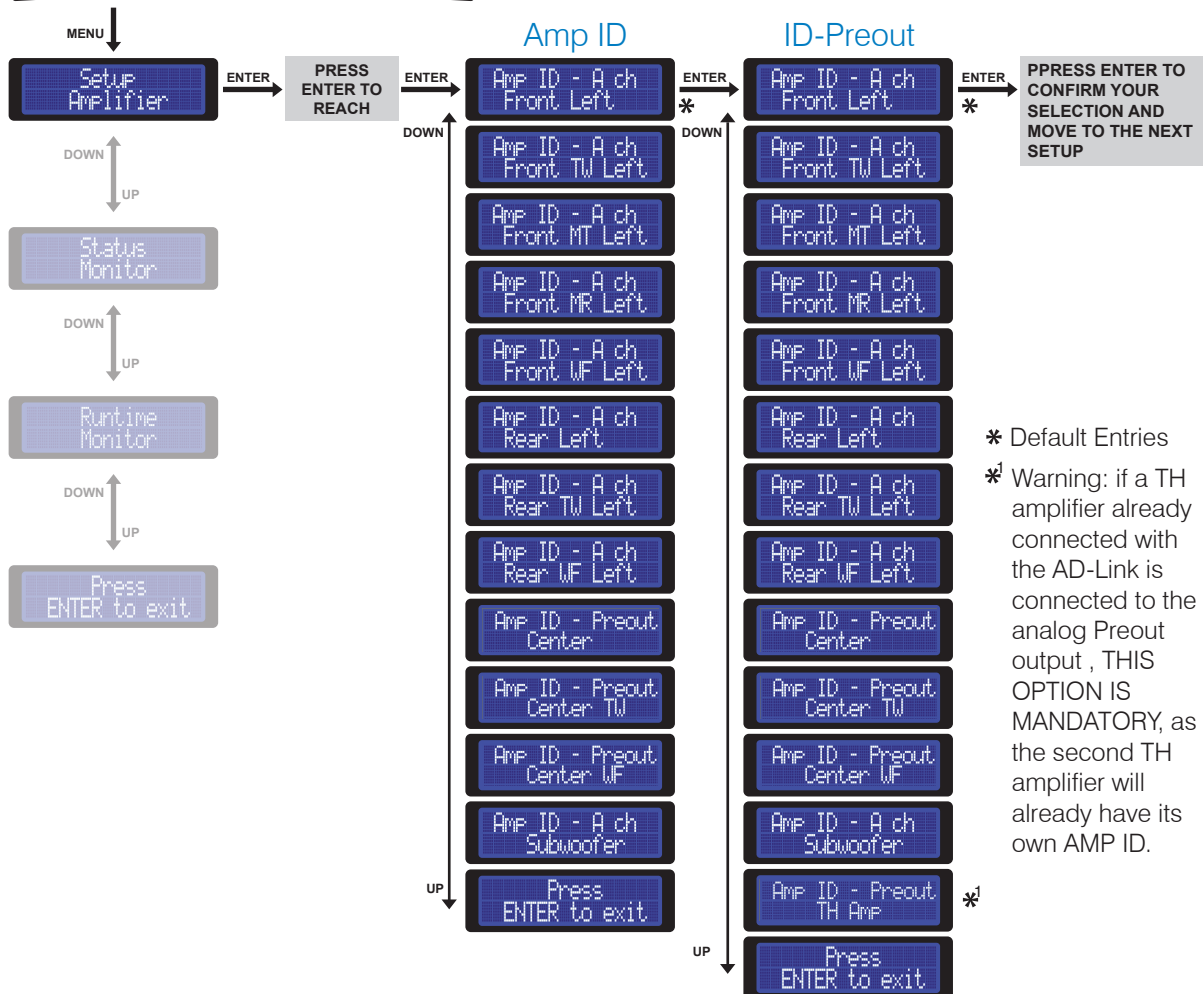
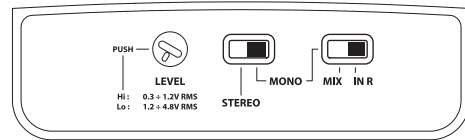
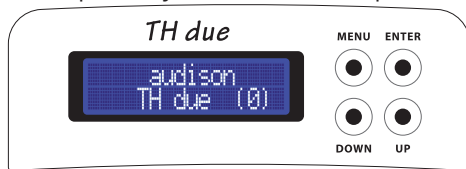

* Default Entries
 *! Warning: if a TH amplifier already connected with the AD-Link is connected to the analog Preout output, THIS OPTION IS MANDATORY, as the second TH amplifier will already have its own AMP ID.



Front Panel

How to adjust the PRE OUT analog output

As already said, the AMP ID can also be assigned to the PRE OUT output, but not only to it. Through the AC Net software also the PRE OUT sensitivity can be adjusted to align the gain of the amplifier connected to that output, thus adapting sensitivity according to the system general volume increase and decrease.

The procedure to perform this operation is the following:

- 1- Connect the (non-TH) amplifier to the PRE output.
- 2- Assign the ID - Preout.
- 3- Set the non-TH amplifier sensitivity to the minimum.
- 4- Through the AC Net slider, increase the output sensitivity until you get the desired volume.
- 5- Should it not be enough, increase the non-TH amplifier input sensitivity

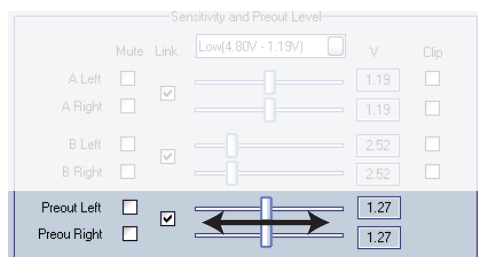
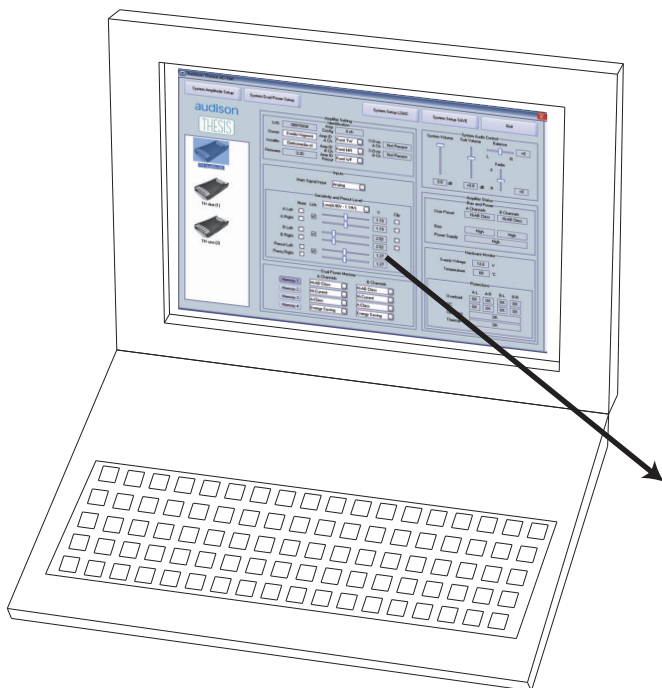
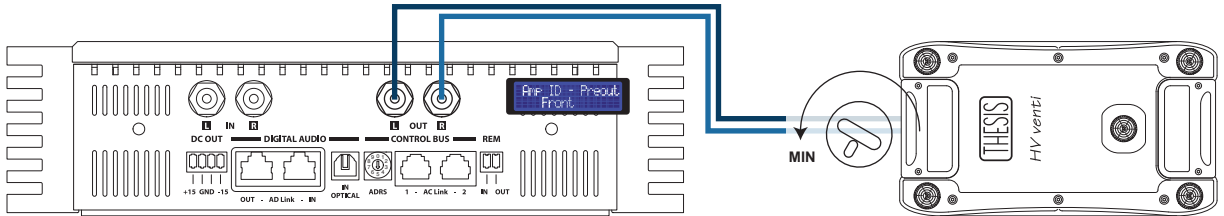
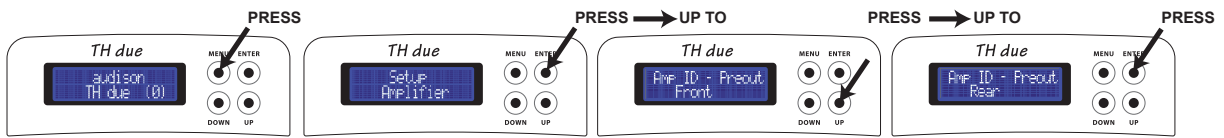



ASC - Amplifier Status Controller

Setup Amplifier : X-Over Slope with TH in Mono mode

When the amplifier is set Mono configuration, you can choose the crossover filter slope.

Select 1- 12 dB/oct: in this case, the Low-pass slope switch on the TH-MXR module will not be active.

Select 2- 24 dB/oct: when this option is selected, the Low-pass slope switch on the TH-MXR module will anyway be active, thus providing the ability to mechanically choosing between 12 and 24 dB/oct.

For further information see page 23 ÷ 27

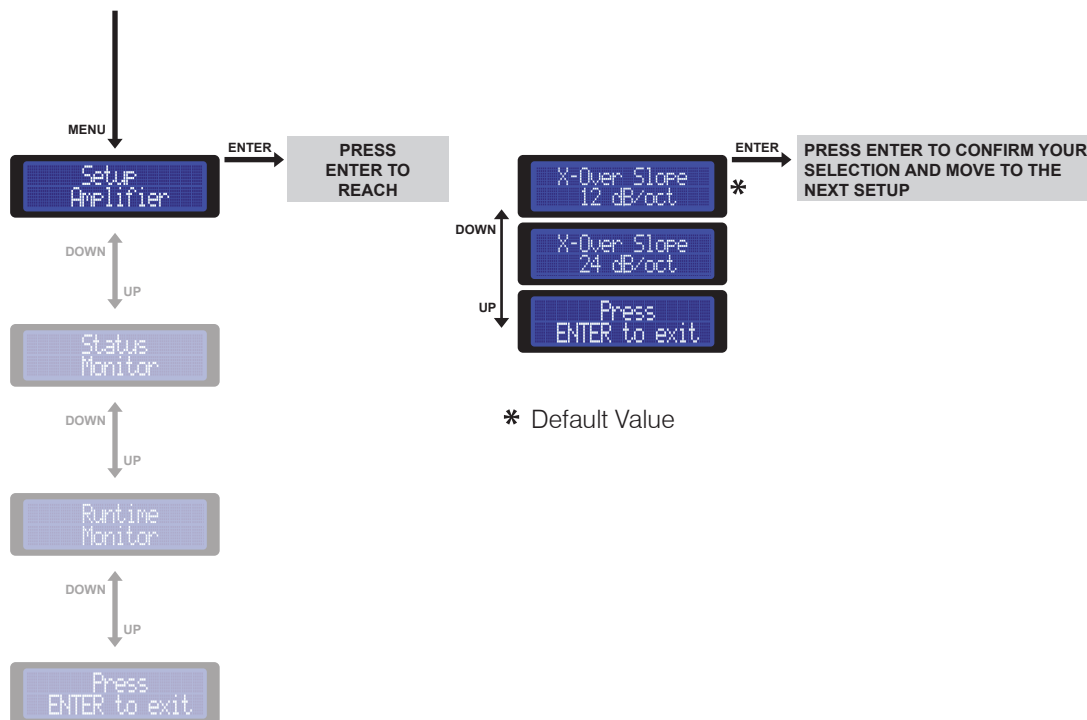
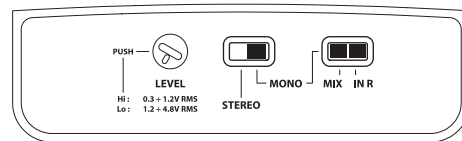
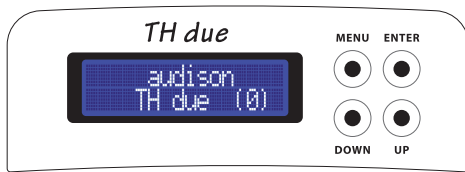



ASC - Amplifier Status Controller

DUAL POWER & BIAS CONTROL

A revolutionary function called Dual Power was introduced for the first time in the HV venti. Controlling the amplifier's output power configuration, this function allowed the predetermination of the amplifiers output power and of the grade of the outputs operational class. The digital interface enables expedient intervention by the user, setting up the amplifier's operational modes by operating on the power and bias current settings, all in real-time. In any case the result is a clear "sound customisation".

In this Setup section you can set the amplifier operational mode.

There are four possible presets:

Class A: to intensify the musical performance; you can not expect the amplifier to drive loads under 4 Ω under these conditions;

Hi-AB Class: it is the default mode, combining the characteristics of high class functioning, great capability of driving difficult loads and high power.

Hi-Current: Pure power, on any loads

Energy Saving: it sets the power emission to the minimum, allowing musical enjoyment for extended periods of time with the vehicles engine off.



When changing mode, you have to wait a few seconds to perceive the acoustic variations. The Dual Power is absolutely independent from the other settings selections. It will work both in Mono and in Stereo configurations, both with and without the crossover, both connecting a subwoofer and a tweeter to it. So we recommend you pay attention to select a functioning mode accepting the impedance load you applied to the amplifier. Check the following page for comparative charts with reference values.

Setup Amplifier: DUAL POWER Settings

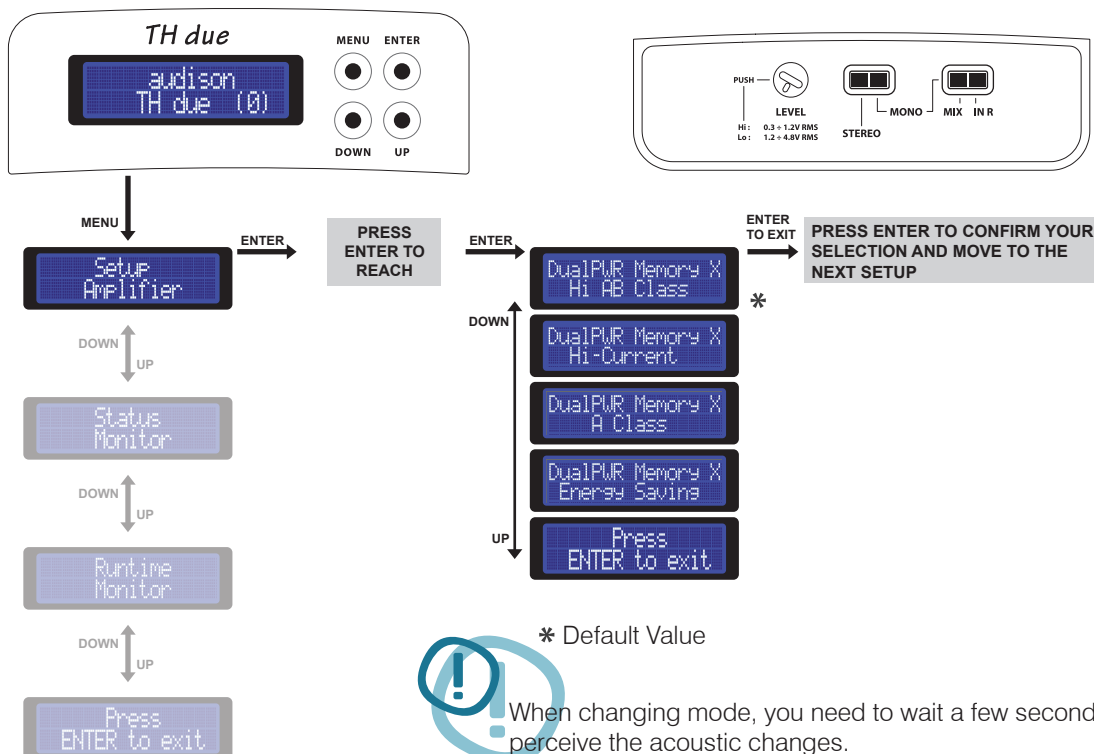

ASC - Amplifier Status Controller

DUAL POWER Values

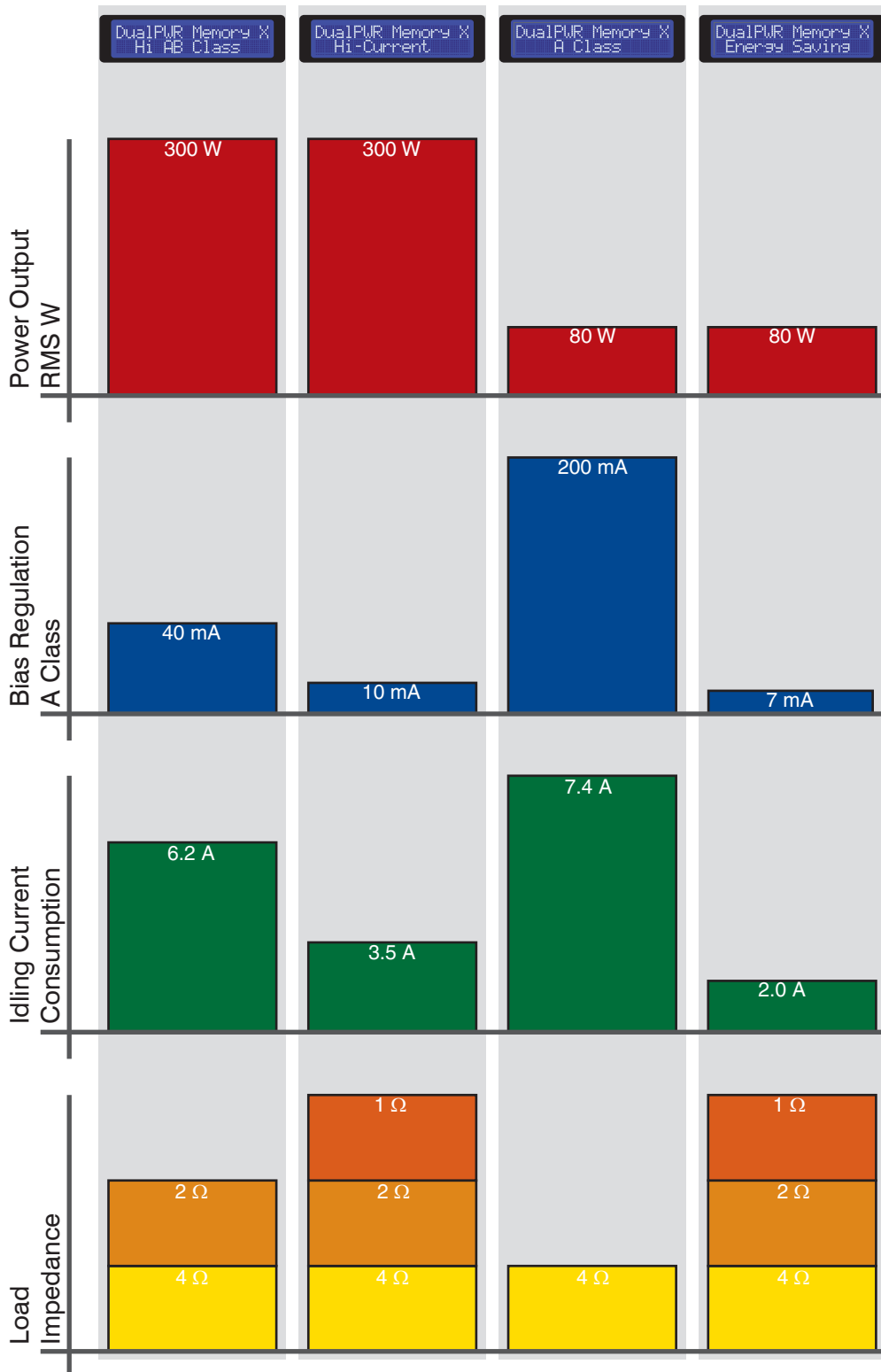



ASC - Amplifier Status Controller

Setup Amplifier: DUAL POWER Settings

How to change presets on the Memory (DRC required)

The TH uno can be set with only one operational mode at a time, while the DRC can manage four customisable memories.

1- Default: In standard configuration, without making any changes, if memory 1 is recalled from the DRC, all the TH amplifiers connected to the system will be working in Hi-AB Class mode (as it is the default setting), while selecting memory 2 they will be workin in Hi-Current mode and so on.

2- Customizing: by acting on both the DRC memories and the ASC control panel of the amplifier, you can create custom setups. For instance, if you want the TH amplifiers to anyway work in A-Class mode, you will have to act on the setup as follows:

- Select memory 1 on the DRC by pressing first SEL and then 1
- Select the A-Class preset on the ASC by accessing to its corresponding setup
- Repeat this operation for each DRC memory
- Repeat this operation for each TH present in the system

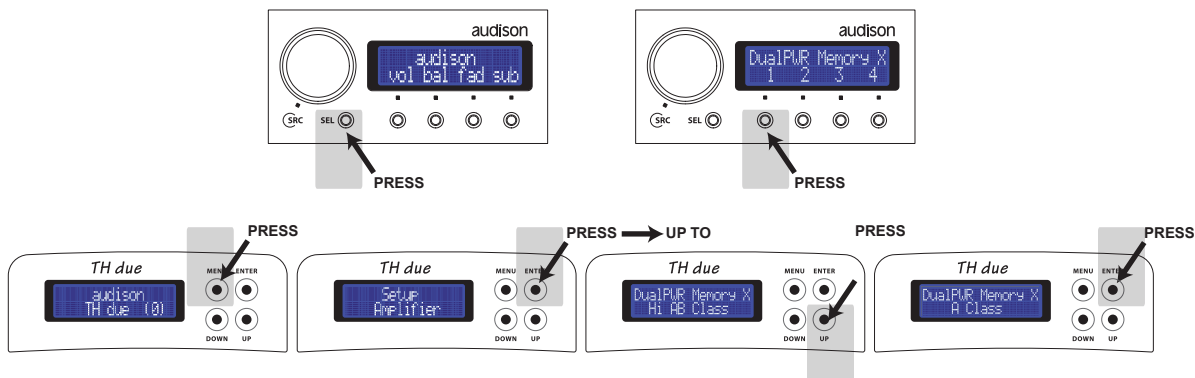

Example: In a three-way + Sub system, multi-amplified with TH quattro on TW and MID, TH due on WF and TH uno on SUB, in default setting if you recall memory 1 all of the TH's would work in Hi-AB Class mode. It is possible to create custom memories, see for instance the example below, to store in memory 1 a system especially designed to ensure top quality for each way or to store in memory 2 a system especially designed for the best power/quality ratio, to store in memory 3 a system set to obtain maximum quality and in memory 4 a system best optimizing the current consumption.

	Default configuration				Modified configuration			
	DRC Memory				DRC Memory			
	1	2	3	4	1	2	3	4
TH quattro	Hi-AB Class	Hi-Current	A Class	Energy Saving	A Class	Hi-AB Class	A Class	Energy Saving
TH due	Hi-AB Class	Hi-Current	A Class	Energy Saving	Hi-AB Class	Hi-Current	A Class	Energy Saving
TH uno	Hi-AB Class	Hi-Current	A Class	Energy Saving	Hi-Current	Hi-Current	A Class	Energy Saving



Example: Three Way+ multi-amplified Sub, TH amplifiers Digital Input

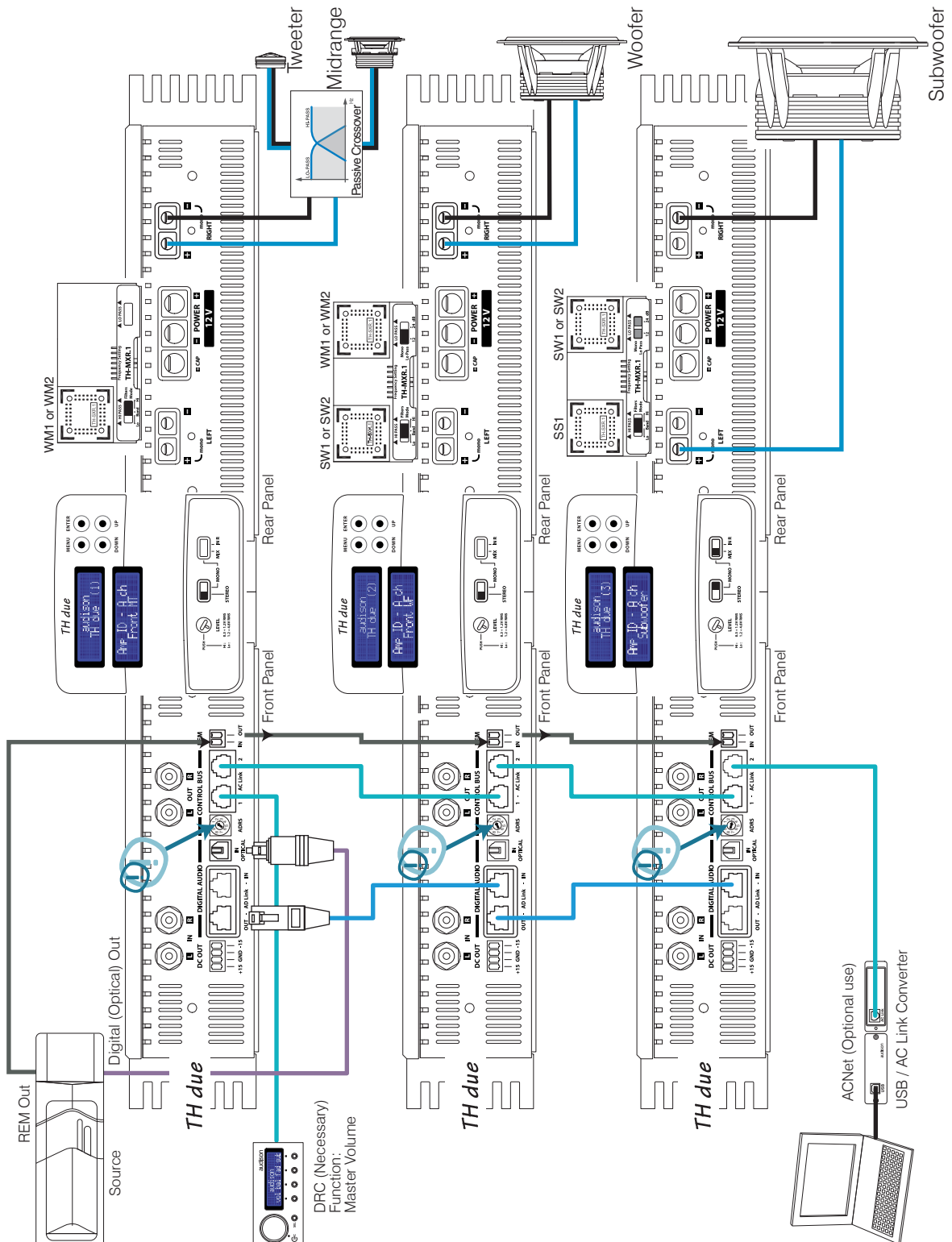

Digital domain



Example: Three Way + multi-amplified Sub, with both TH and non-TH amplifiers. Analog + Digital Input

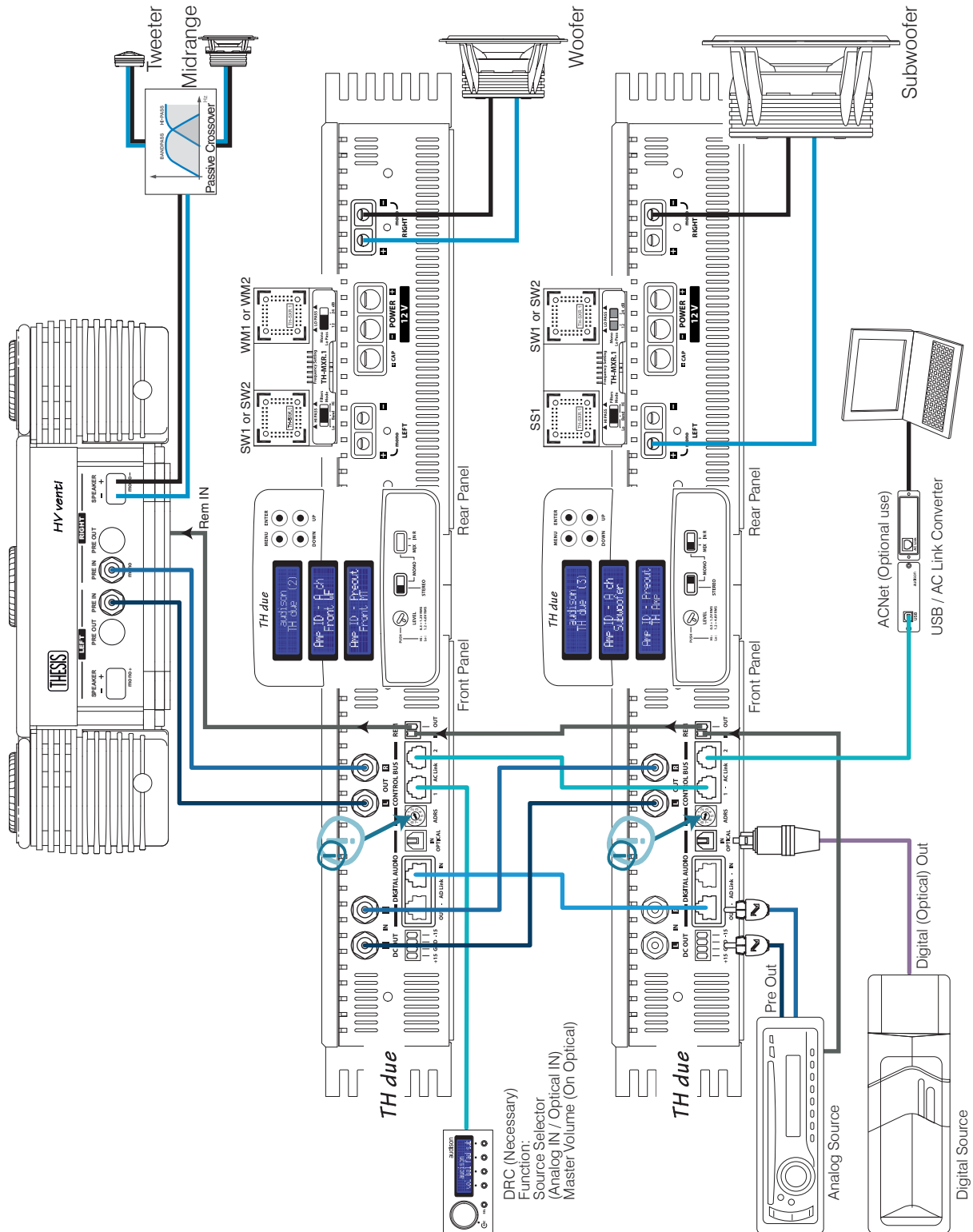



ASC - Amplifier Status Controller

Status Monitor

This feature of the ASC provides the ability to monitor the amplifier working status by moving through the different entries the data regarding the working TH amplifier will show. When displaying a value, if you do not act on any of the buttons for 5 seconds, the ASC automatically goes back to the default display screen.

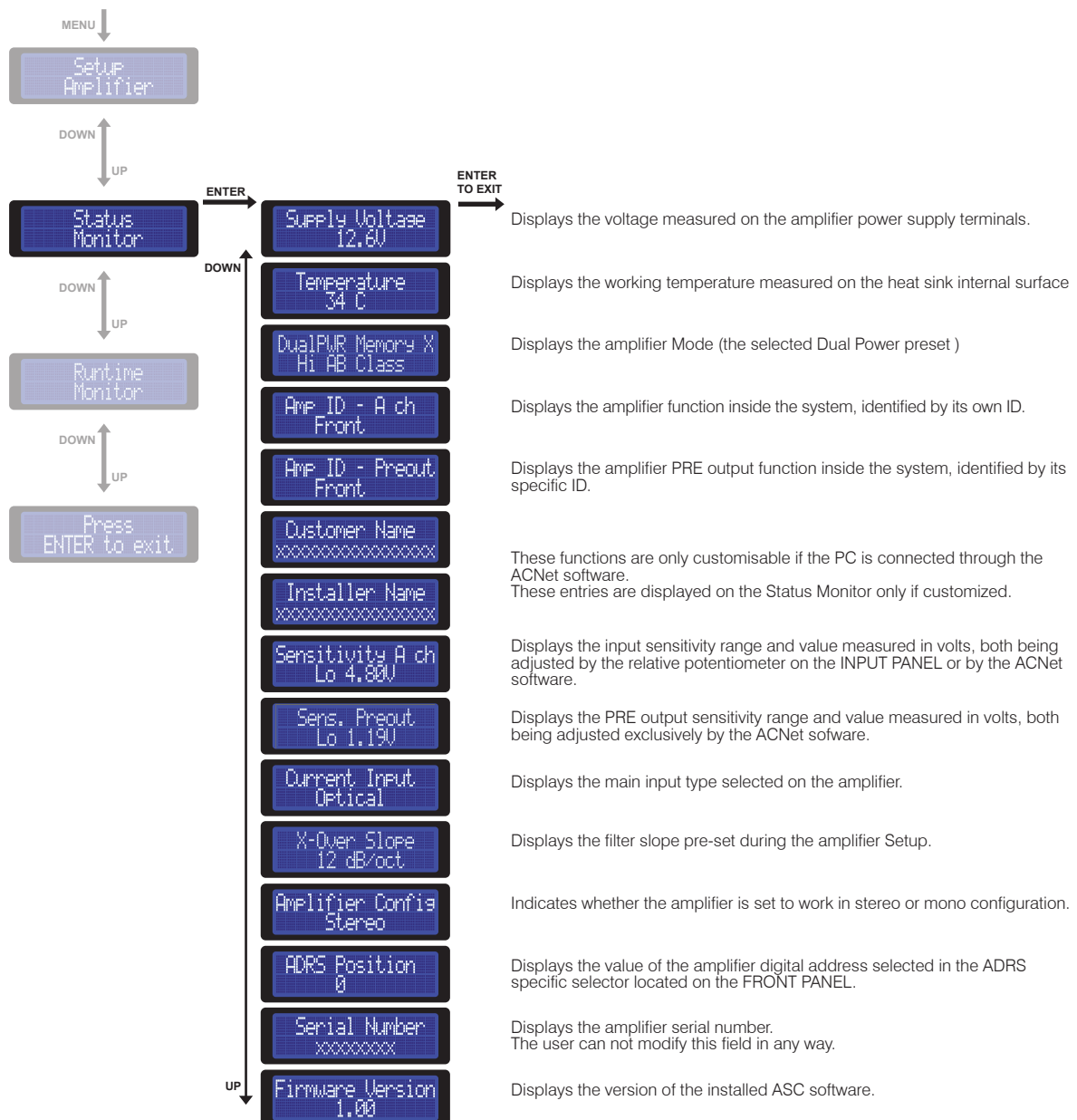



ASC - Amplifier Status Controller

Runtime Monitor

This function of the ASC provides the ability to alternately show on the amplifier display the information on its operational status. Through this setup you can select the fields you want to be visible when the amplifier is on. For each field you can select YES to have the entry show on the display. If all NO are selected, the display will always show the default display screen. You will only have to select even just one entry to see it appear alternately on the display while the amplifier is working. By default all the fields are pre-set on NO.

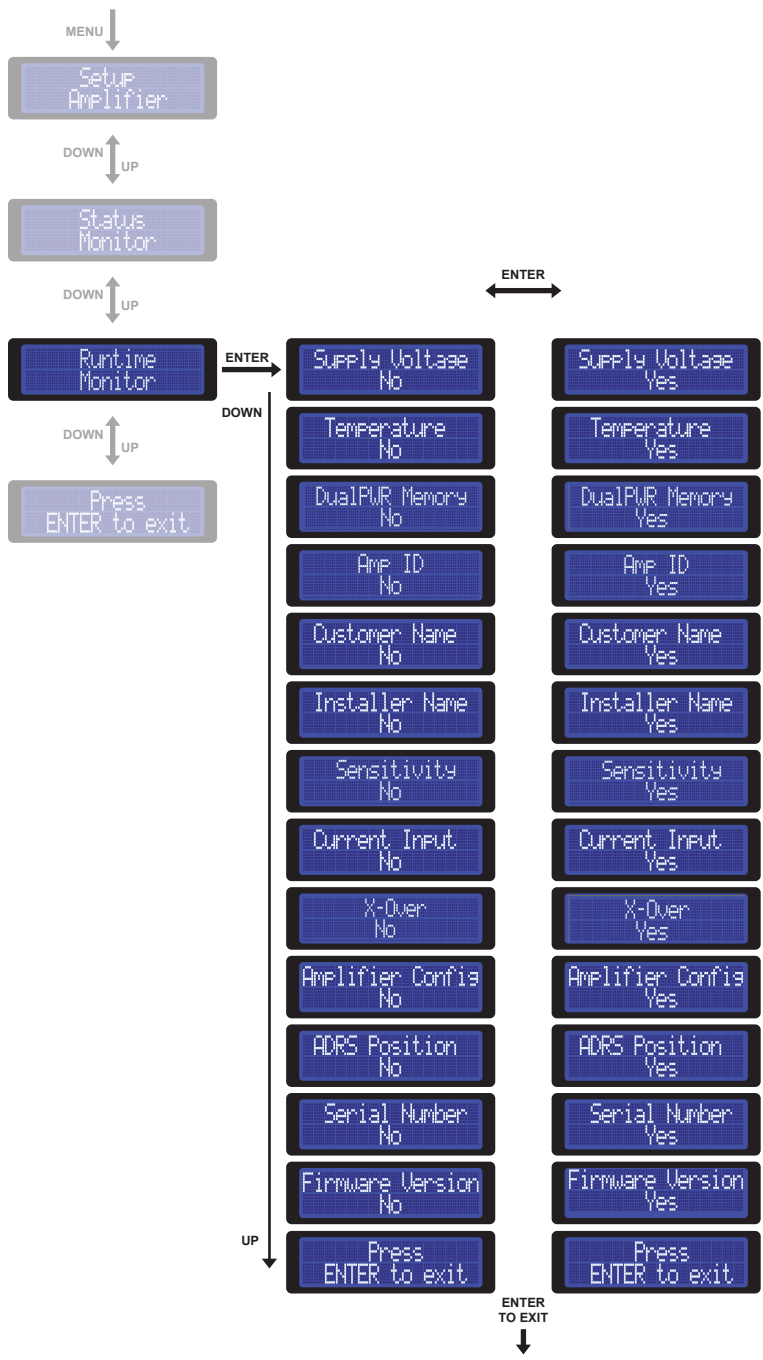



ASC - Amplifier Status Controller

Info and Alert sentences

	What the TH is doing	What the display is showing	What it means
1	Amp in default		The previously found connection with DRC has been lost. This information is also displayed when the amplifier is on and the DRC gets disconnected. Volume goes back to 0 dB (the set sensitivity is not modified). Balance and Fader are set back to their centre position (0). The Sub volume is set back to 0 dB. The ANALOG input is automatically selected.
2	Amp in muting		MONO-STEREO switch position is different from the original position acquired during the Amplifier Setup (STEREO). You have to access to the ASC and at least set the AMP ID.
3	Amp in muting		MONO-STEREO switch position is different from the original position acquired during the Amplifier Setup (MONO). You have to access to the ASC and at least set the AMP ID.
4	Amp off	*	Left channel general protection. The amplifier will try to restart 5 times. Contact Audison Technical Support.
5	Amp off	*	Right channel general protection. The amplifier will try to restart 5 times. Contact Audison Technical Support.
6	Autoreset	*	Left channel overload protection. Check speaker load. This message is displayed when an overload occurs.
7	Autoreset	*	Right channel overload protection. Check speaker load. This message is displayed when an overload occurs.
8	Event's alert		Rare overload occurs on Left channel. Check speaker load. This message is displayed when an overload has already occurred but the amplifier restarted.
9	Event's alert		Rare overload occurs on Right channel. Check speaker load. This message is displayed when an overload has already occurred but the amplifier restarted.
10	Event's alert	*	Left channel output is reaching distortion threshold. The information is immediate and stays displayed only while distortion is still present.
11	Event's alert	*	Right channel output is reaching distortion threshold. The information is immediate and stays displayed only while distortion is still present.
12	Autoreset	*	Thermal protection. Check environmental temperature and/or use a low bias Dual Power setting.
13	Event's alert		Rare thermal protection occurs. Check environmental temperature and/or use a low bias Dual Power setting.
14	Autoreset	*	Contact with ground. Stop listening and check speaker cables.
15	Event's alert		Rare contact with ground occurs. Stop listening and check speaker cables.

* These messages appear also on the DRC display. The DRC will display amplifier name and ADRS on the first row.

DRC - Digital Remote Control

(not provided with TH amplifier)

The DRC is a microprocessor digital system providing remote control and monitoring of the TH amplifiers. Once connected it performs important functions such as:

- Source selection (it also provides the ability to use the optical digital input as main source, checking its main volume)
- Main volume control
- Subwoofer volume control
- Right/ left balance control
- Front/rear Fader control
- Dual Power working memory Manager
- Status Monitor for all the amplifiers in the system

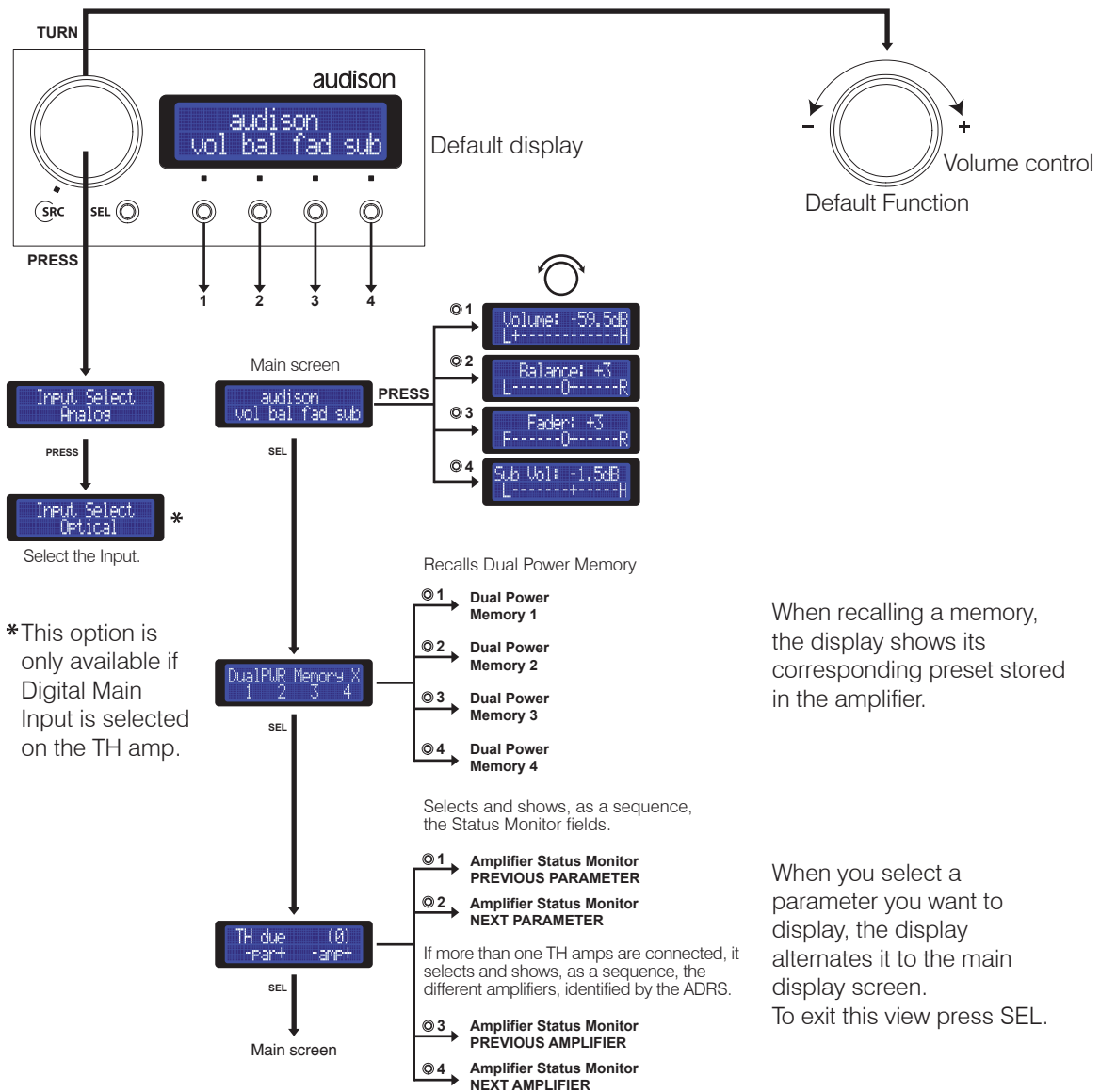

DRC - Digital Remote Control

Info and Alert sentences

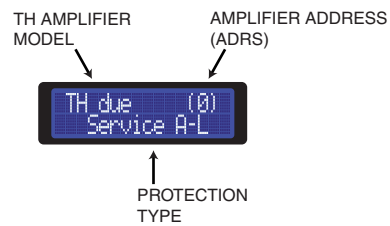

Amp off		Left channel general protection. Call Audison Technical Support.
Amp off		Right channel general protection. Call Audison Technical Support.
Autoreset		Left channel overload protection. Check speaker load.
Autoreset		Right channel overload protection. Check speaker load.
Event's alert		Left channel output is reaching distortion threshold.
Event's alert		Right channel output is reaching distortion threshold.
Autoreset		Thermal protection. Check environmental temperature and/or use a low bias AMC setting.
Autoreset		Rare contact with ground occurs. Stop listening and check speaker cables.
Event's alert		The PC is connected and ACNet software is running. The DRC is disabled.

DRC - Digital Remote Control

DRC - How to connect

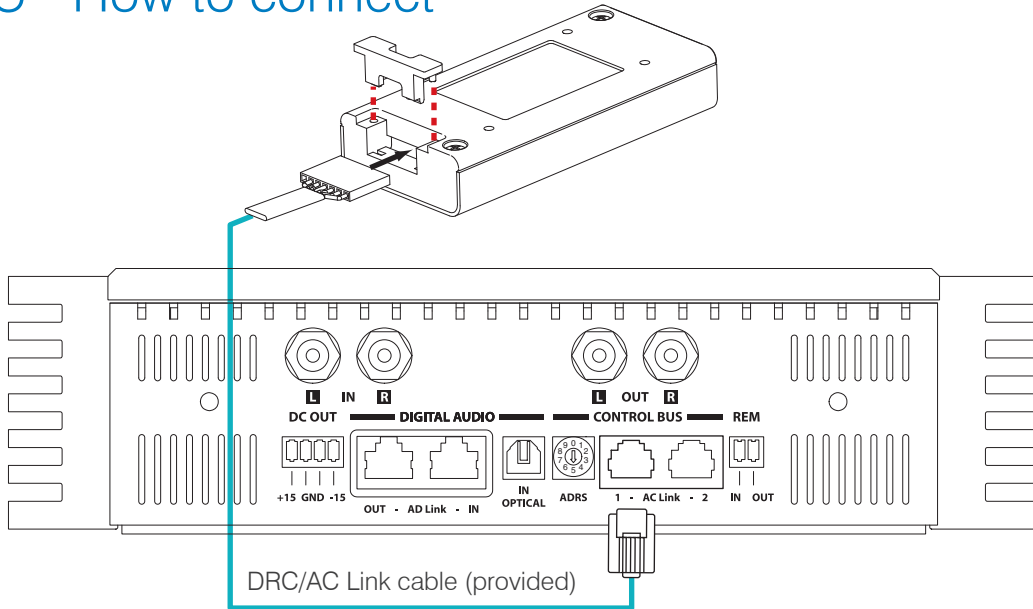

DRC - How to install

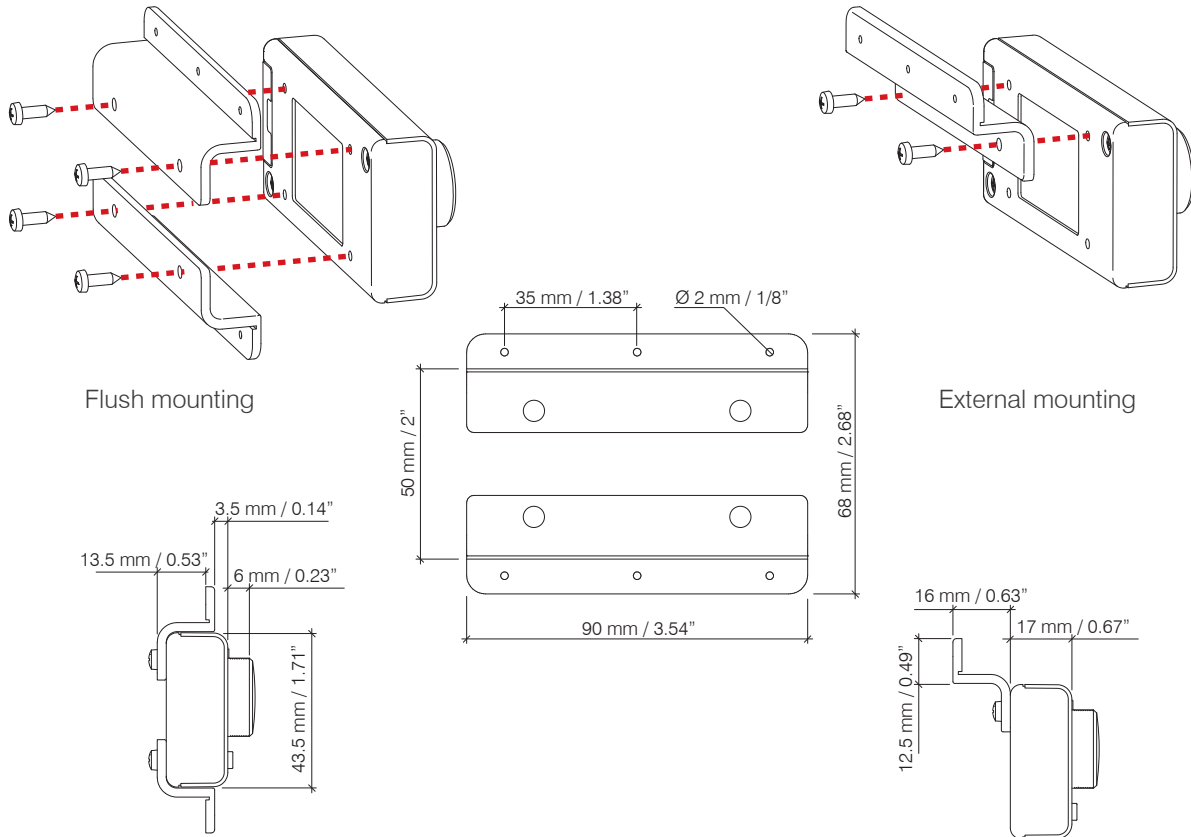



ACNet - Audison Control Network

Software to control Audison amplifier

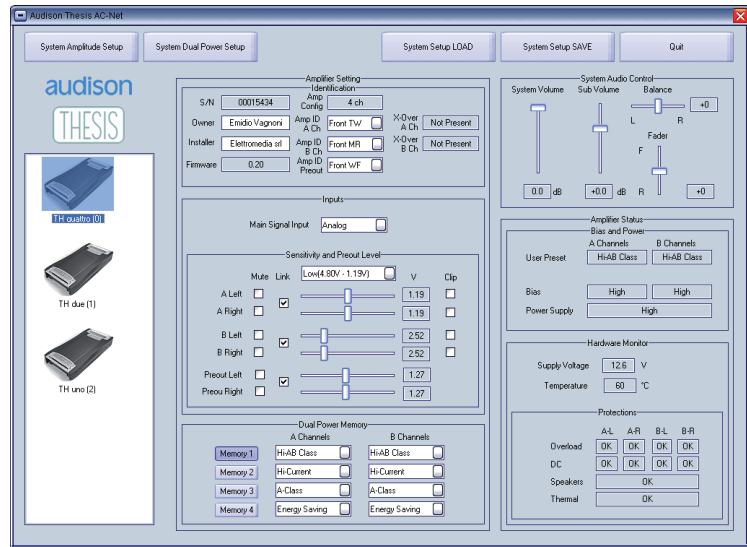

Hardware Requirements:
 1024x768 Display Optimized - 96 dpi Font size - 1 x USB port (1.1 compliant)

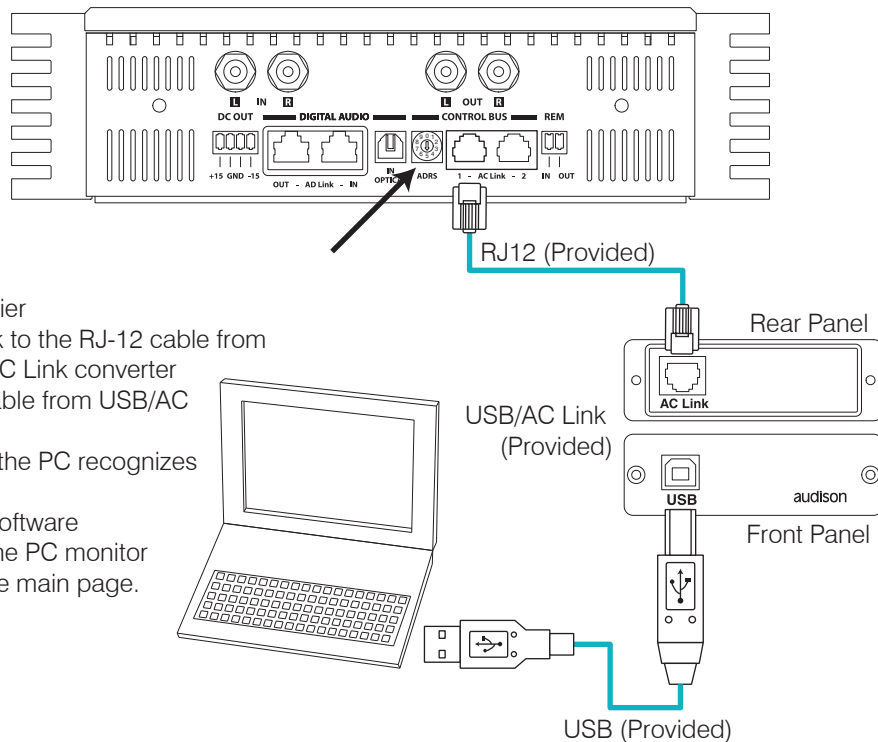

- 1 - Switch on the PC
- 2 - Switch on the amplifier
- 3 - Connect the AC Link to the RJ-12 cable from the TH to the USB/AC Link converter
- 4 - Connect the USB cable from USB/AC Link converter to PC
- 5 - Wait 5/10 secs until the PC recognizes the USB connection
- 6 - Launch the ACNet software
- 7 - If everything is OK the PC monitor displays the software main page.



ACNet - Audison Control Network

Functions Description

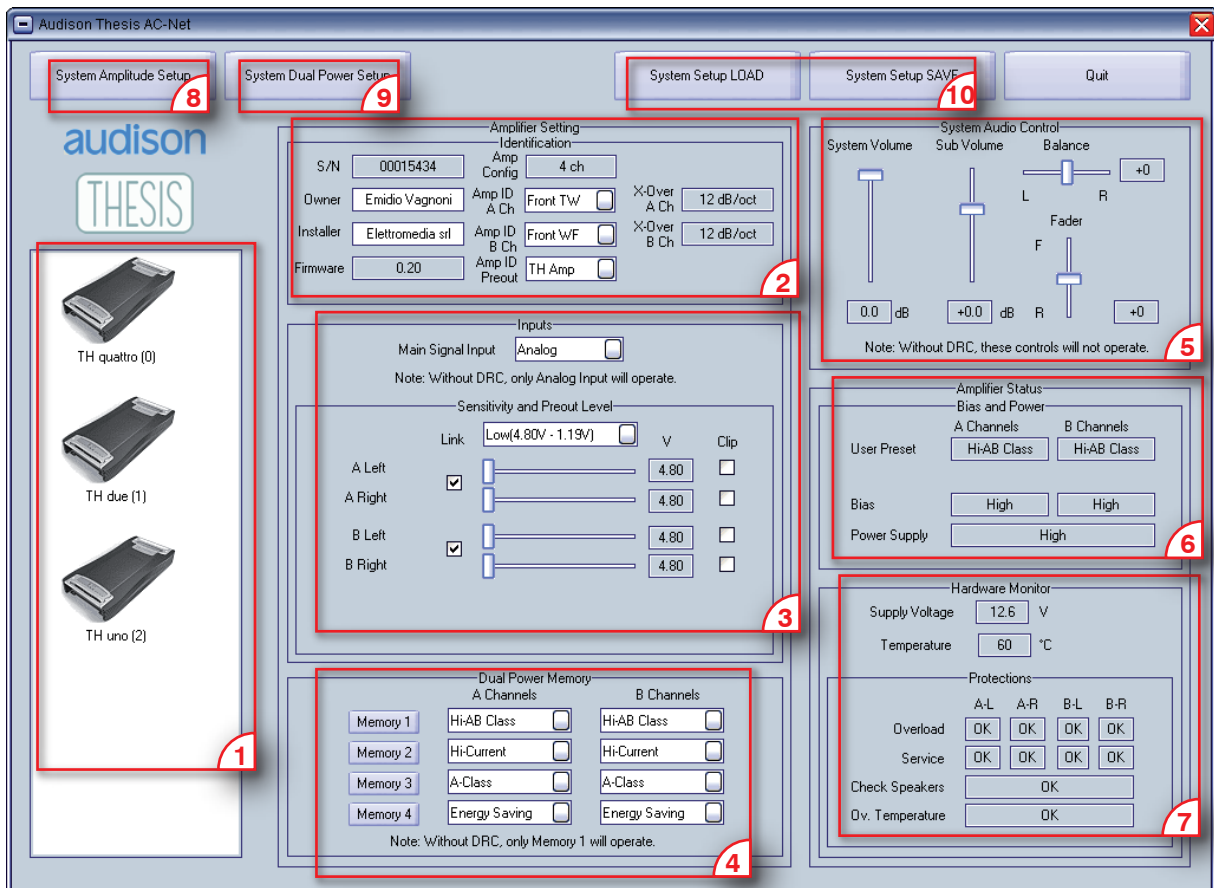

- 1 • **SYSTEM DISPLAY:** on this area the TH amplifiers connected to the system through the ACLink will be displayed. This screen will show the TH amplifier model name and its ADRS.
- 2 • **IDENTIFICATION:** This area shows report boxes and active fields, which enable the identification of each single amplifier.
- 3 • **INPUTS:** In this section it's possible to adjust each feature relating to the TH amplifier inputs
- 4 • **DUAL POWER MEMORY:** This menus allow the function setting for each amplifier separately.
- 5 • **SYSTEM AUDIO CONTROL:** The sliders in this area operate on the low level audio controls of the whole system.
- 6 / 7 • **AMPLIFIER STATUS:** This section is the real monitor of the amplifier's vital functions.
- 8 • **SYSTEM AMPLITUDE SETUP:** This function enables the input sensitivity of the amplifiers in the system.
- 9 • **SYSTEM DUAL POWER SETUP:** This function enables the function setting of all the amplifiers in the system.
- 10 • **SYSTEM SETUP LOAD/SAVE:** It guarantees the saving of the whole system setup or the loading of setups previously saved.

ACNet - Audison Control Network System Display

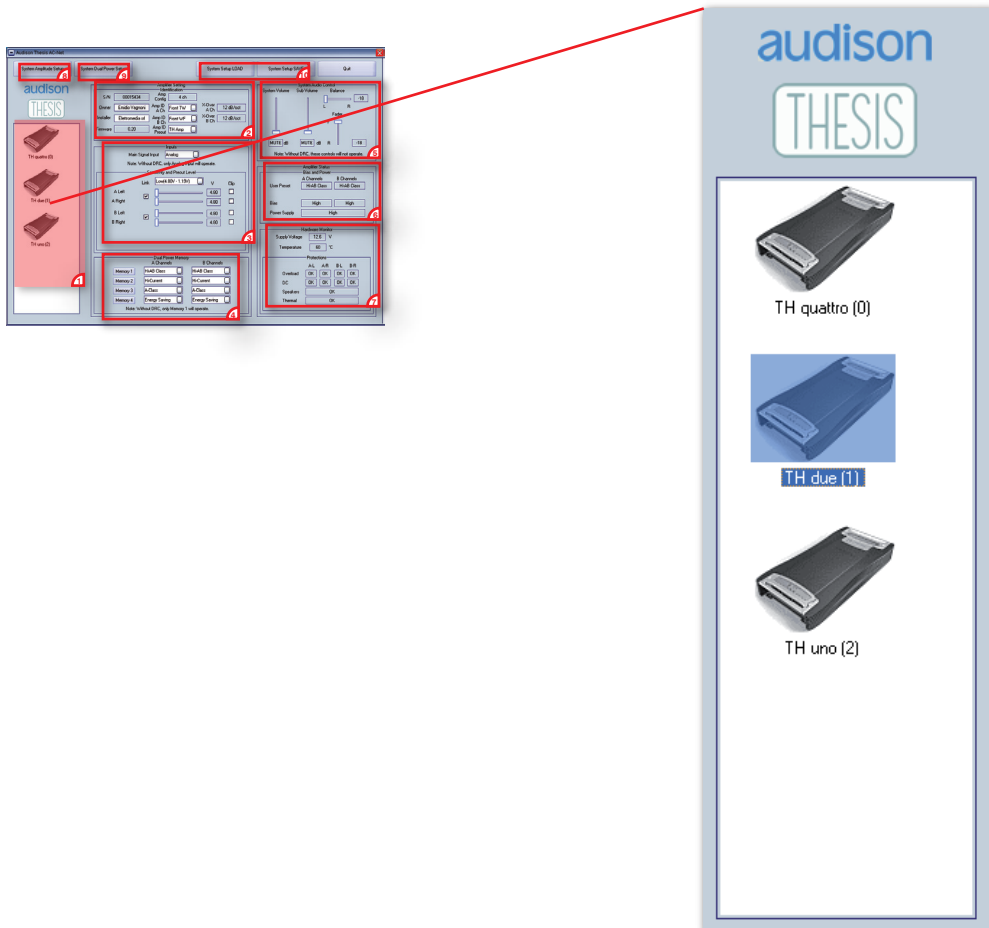

When installing a system composed by TH amplifiers it's possible to create a network between them by using ACLink series connection.

It is fundamental that a different ADRS starting from zero is assigned to each amplifier (see page 18).

In this way, when the software is turned on, the system will be able to automatically recognize which amplifier is present in the network.

This display will show all the "linked" amplifiers creating an icon corresponding to the model, the model name and the ADRS set during the installation.

The ACNet software allows the user to work either on one single amplifier or on the whole system.

In order to understand the use of the software we will work on a three way system + sub, multi-amplified, using a TH quattro on Tweeter and Midrange, TH due on Woofer and TH uno on Subwoofer.

For example, to work on a TH due double click on its dedicated icon. The name will be highlighted and its corresponding data will be displayed in the specific fields.



ACNet - Audison Control Network

Amplifier Setting: Identification

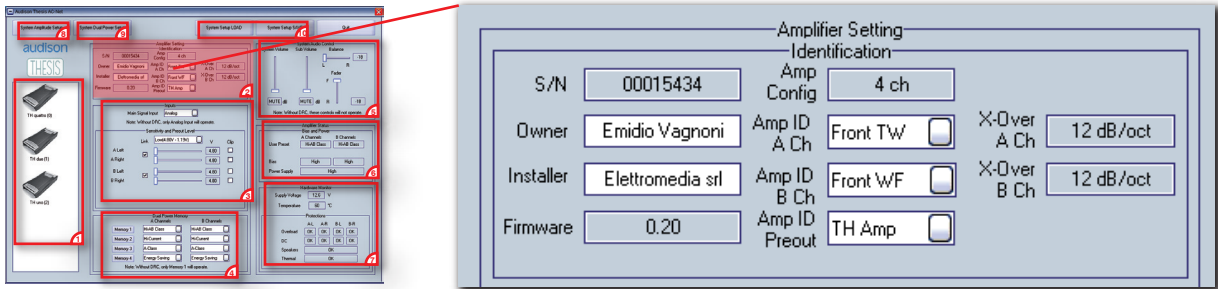

The amplifier identification provides its S/N - serial number (fixed), the owner name (free-text), the installer name (free-text) and the Firmware release included in the microprocessor inside the TH amplifier. The ACNet area shows the amplifier configuration (mechanically set in the TH Input Panel) and allows the Amp ID and AmpPreout setting through a drop-down menu. The report boxes on the right confirm if any crossover modules have been used inside the amplifier and which slope setting has been given.

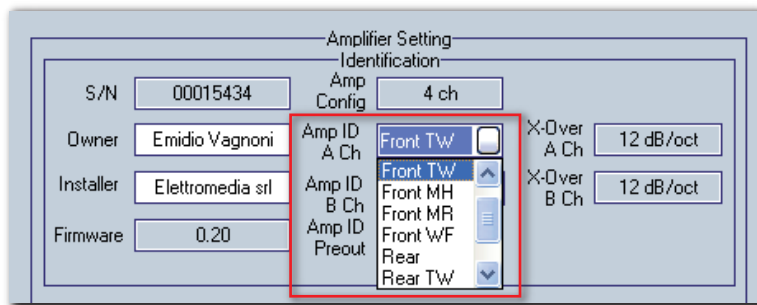

The drop-down menu displays the available values to be assigned to the amplifier depending on its configuration / functioning modes. For example, if the amplifier it's mono set, the available ID will be the specific ones for the mono setting.

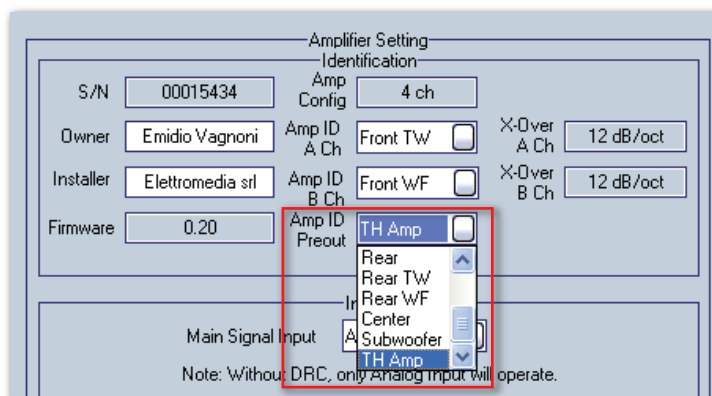

If the system is also composed by non-TH amplifiers, they can be managed by attributing an ID to the Pre Out connected to them. The menu default option is "TH AMP", because generally a TH amp (provided with its specific Amp ID already) is connected to the Pre Out.



ACNet - Audison Control Network

Amplifier Setting: Inputs

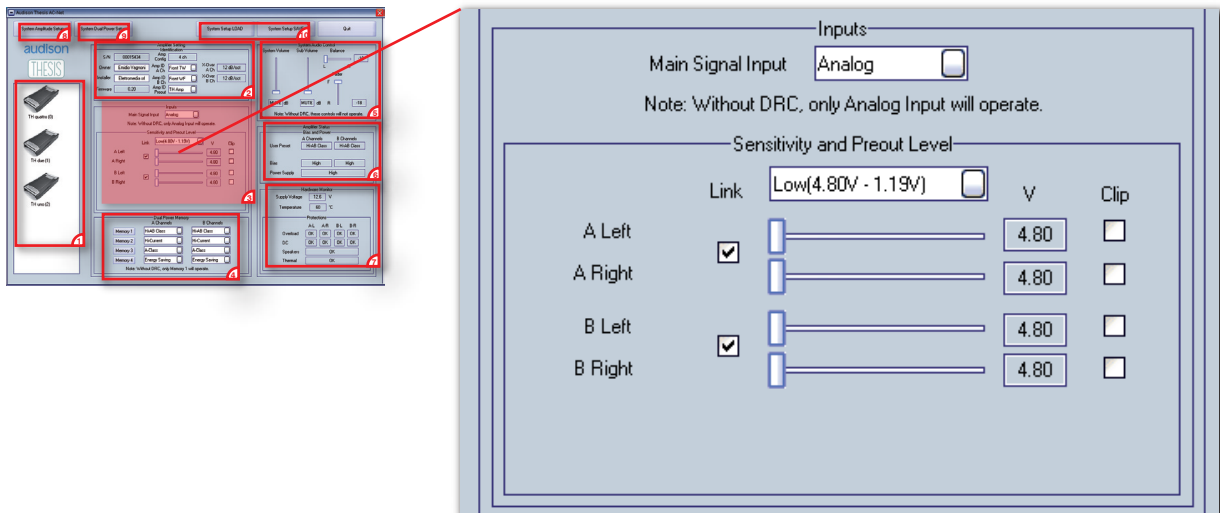

As for the ASC Setup Amplifier, it is necessary to set the system whenever wanting to use the digital input. In this area it is necessary to select the Main Signal Input for each amplifier connected to the system

- Example:
- If the amplifier being set is the first of the network to receive the signal from an external source, it is necessary to specify if it is an analog or digital one, by selecting Analog or Optical Master.
 - If it is connected to both an analog and a digital source, select Optical Master and manage the sources switch through the DRC.
 - If the amplifier being set receives the signal from another TH amp, connected in analog and digital AD Link, select Optical Slave .
 - If the amplifier being set receives the signal from an external audio processor (Ex: Audison Bit One) select AD Link.

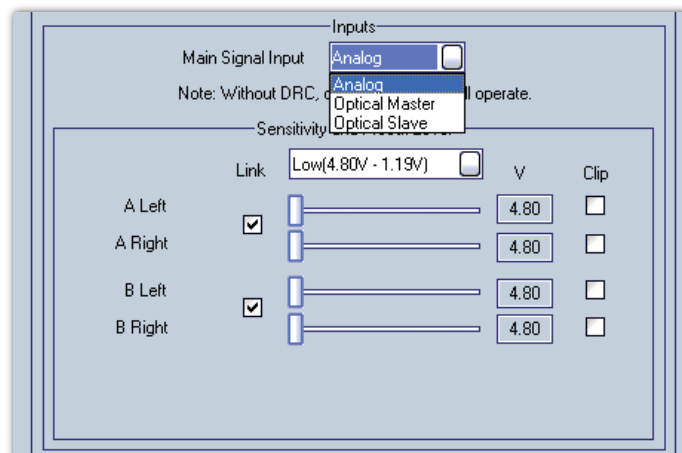

The note warns that if the DRC is not connected to the system, even selecting a digital input, when ACNet software will be switched off, only the Analog Input will operate.



ACNet - Audison Control Network

Amplifier Setting: Sensitivity and Preout Level

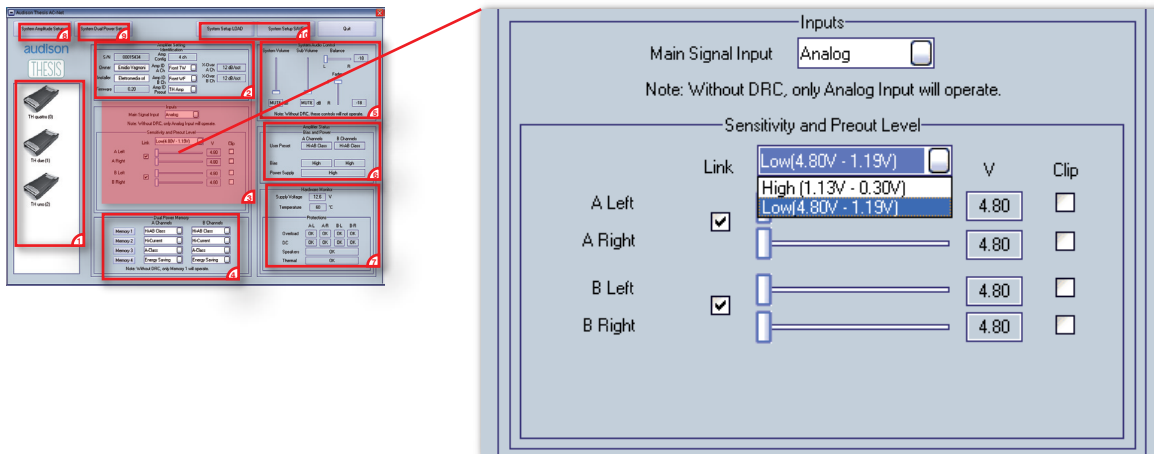

From this section featuring drop down menus, it is possible to regulate each amplifier's input sensitivity, acting also on the High/Low Level.

There are sliders for each channel which can work singularly or together if "linked". The software enables the fine tuning between right and left, acting on the corresponding slider. The software will show the level measured in V.

The LED Clip flashes when the max level is reached during tuning or playing.

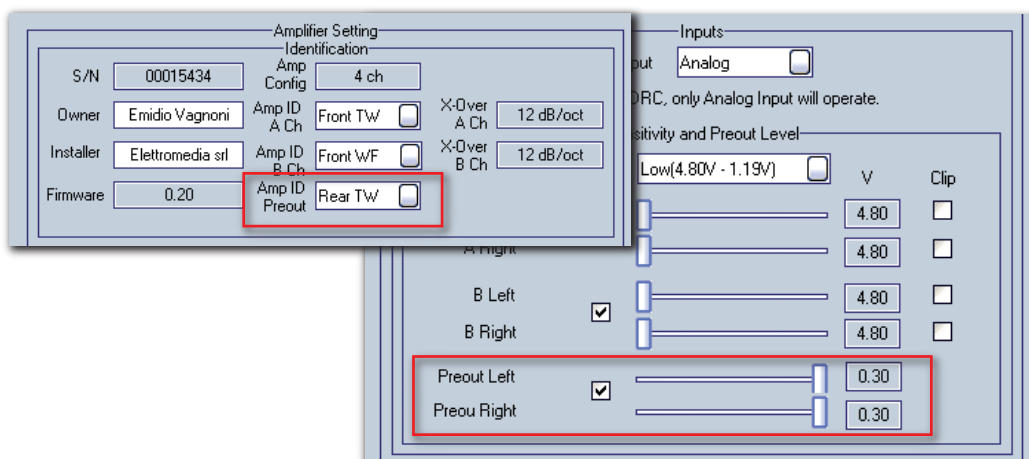

When using a non-TH amplifier to be controlled by DRC, an ID must be assigned to the Pre Out where it is connected. In this way it is still possible to manage the TH Preout sensitivity.

The specific sliders will come into view only when a name which is not TH Amp is given to the active field.



ACNet - Audison Control Network

Amplifier Setting: Dual Power Memory

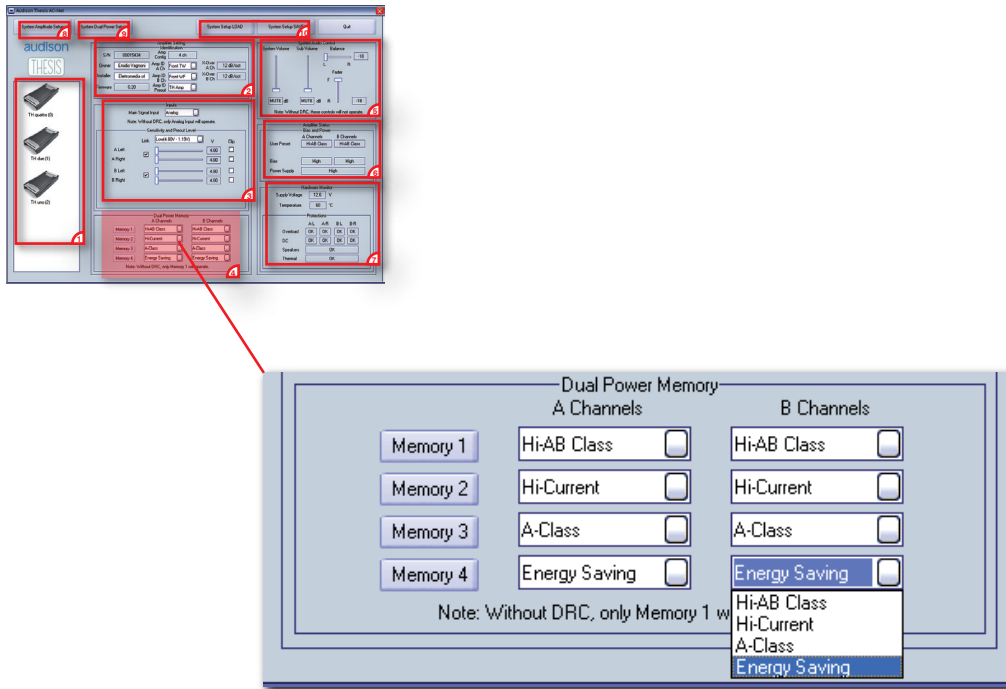

In this section the TH amps operating modes memories can be selected. The available preset are: Hi-AB Class (default), Hi-Current, A-Class, Energy Saving. They can be assigned to each single memory by using the drop down menus. The memories can be recalled through the Memory keys 1 / 2 / 3 / 4 but when ACNet software is switched off, if the DRC is not connected to the system, the function selected on Memory 1 will be operating. TH uno and TH due can only work with one preset, while TH quattro can work with one preset on A Channels and one on B Channels. Note: When the preset A-Class or Energy Saving is assigned to A Channels, this will be automatically applied to B Channels. Please refer to the following table:

TH quattro

	1	2	3	4	5	6
Channels A	Hi-AB Class	Hi-Current	Hi-AB Class	Hi-Current	A Class	En.Saving
Channels B	Hi-AB Class	Hi-Current	Hi-Current	Hi-AB Class	A Class	En.Saving



ACNet - Audison Control Network System Audio Control

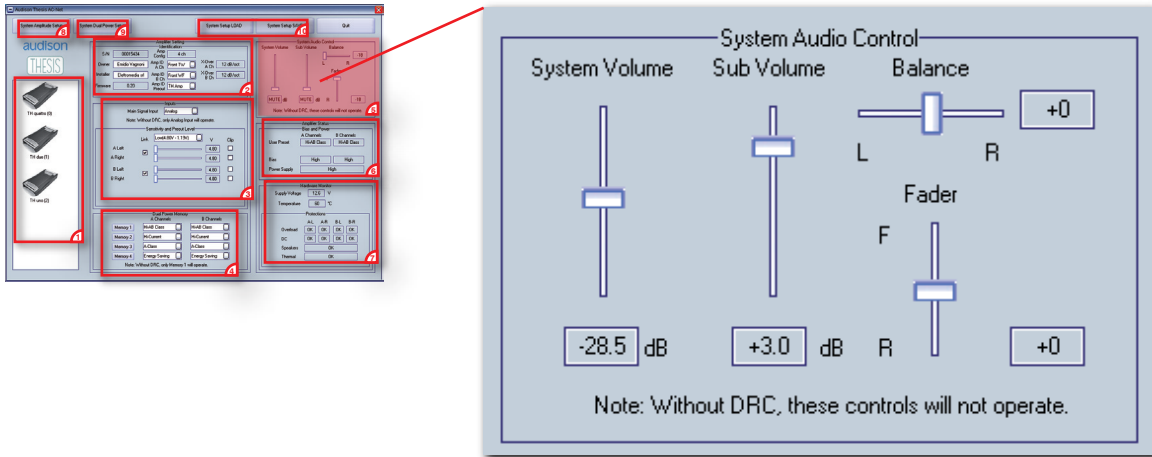

These controls act on the whole system:

- **System Volume:** it's the main volume control of the system, the slider on Min position switches on the muting and shows "MUTE" in the specific box. The adjustment starts from -60 dB (muting) up to 0 dB Max, 0,5 dB steps.
- **Sub Volume:** it's the specific volume control for the subwoofer, the slider on Min position switches on the muting and shows "MUTE" in the specific box. The adjustment starts from -12 dB (muting) up to +6 dB Max, 0,5 dB steps.
- **Balance:** it's the control that allows the left and right balancing. When in central position (+0) the output volume between left and right it's identical. It's possible to unbalance the output volume of one channel compared to the other.
- **Fader:** it's the control that allows the Front and Rear balancing. When in central position (+0) the output volume between Front and Rear it's identical. It's possible to unbalance the output volume of one zone compared to the other.

The Amp ID of each single amplifier inside the system must be set correctly in order to operate the audio controls. The Sub Volume control, for example, will only operate on the amplifiers identified on the Amp ID as Subwoofer. The Balance control will operate on all the amplifiers characterized by the presence of a right and left channel (it will not operate on Central and Subwoofer).

The note warns that if the DRC is not connected to the system, when ACNet software is switched off, these controls will not operate.



ACNet - Audison Control Network

Amplifier Status

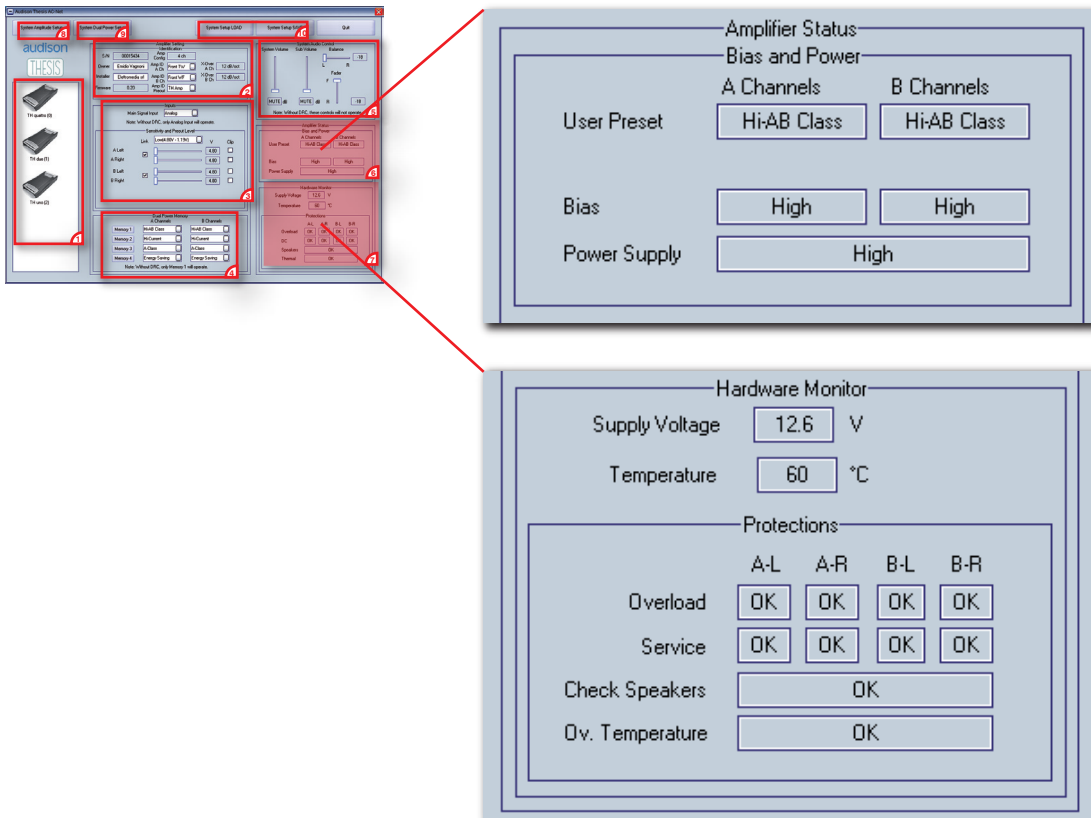

The ACNet software performs a real-time check-up of the amplifiers operating conditions. Once an amplifier is selected, the parameters monitored by the ASC microprocessor are shown on the specific boxes.

Bias and Power

- **User preset:** displays the operating modes selected in the Dual Power Setting. For the TH quattro the operating modes of both channels A and B are shown.
- **Bias:** displays the bias current value corresponding to the preset in use.
- **Power Supply:** displays the power supply value corresponding to the preset in use.

Hardware Monitor

- **Supply Voltage:** displays the power supply voltage (V) measured on the amplifier terminals.
- **Temperature:** displays the amplifier working temperature measured in °C.
- **Protections:** the protection conditions are provided for each channel.
 - Overload:** warns when an extremely low load has been connected to the amplifier speaker terminals or when a temporary overload has occurred;
 - Service:** warns when DC current is coming out of the speaker terminals;
 - Speakers:** warns when a short-circuit has occurred in the connection between amplifier and speakers;
 - Ov. Temperature:** warns when an operating temperature, dangerous for the amplifier, has been reached.



ACNet - Audison Control Network

System Amplitude Setup

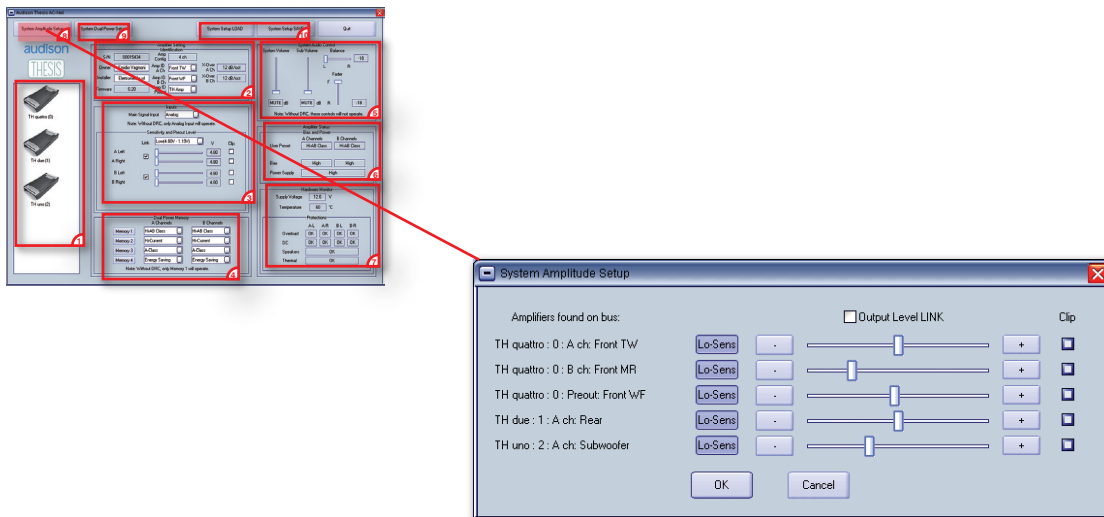

Once each single amplifier in the system has been set, it is possible to use the setup window above, which allows the sensitivity adjustment of all amplifiers of the entire system. Using this section, it's possible to operate in an even mode on the amplifiers level tuning. Sliders will work singularly on each amplifier and, selecting the Output Level LINK key, it's possible to tie all the sliders together and modify the main system level. The LED Clip flashes, when the max level is reached during tuning or playing.

Single level adjustment

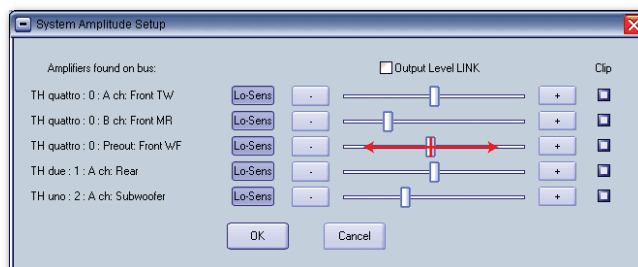

Whole system level adjustment

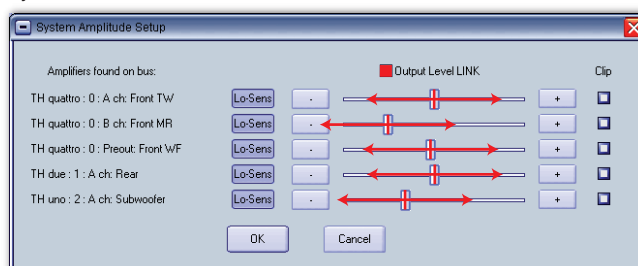



ACNet - Audison Control Network System Dual Power Setup

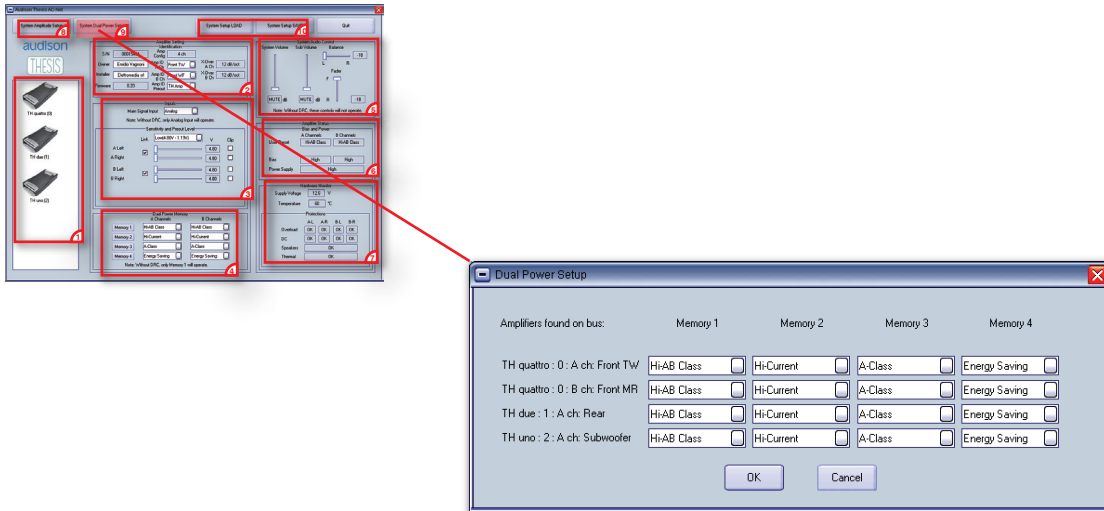

This setup enables the complete management of the operating mode of the amplifiers in the systems. The chart above presents in one window all the amplifier names and channels being used.

The fields are provided by default as in the example above. When wanting to achieve peculiar operating modes, depending on the acoustics results requested to the system, it is possible to modify the preset sequence.

Examples:

- To achieve the best quality/performance ratio system, select A-Class for TH quattro, Hi-AB Class for TH due and Hi-Current for TH uno.
- To achieve the best power/performance ratio system, select Hi-AB Class for TH quattro, Hi-Current for TH due and Hi-Current for TH uno.
- To achieve the highest audio quality system, use Memory 3.
- To achieve an unextended listening time while the car is parked, use Memory 4.



Technical Specifications

Power supply

Voltage	11 ÷ 15 VDC
Idling current:	
A-Class	7.4 A
Hi-AB Class	6.2 A
Hi-Current	3.5 A
Energy Saving	2.0 A
Switched off	0.04 mA
Consumption @ 14.4 VDC, 1 Ω, Max musical power	105 A
Remote IN voltage	7 ÷ 15 VDC (1 mA)
Remote OUT voltage	12 VDC (50 mA)
Internal fuse (AFS)	100 A

Amplifier stage

Distortion - THD @ 1 kHz, 4 Ω, 90% Power	0.02 %
Bandwidth @ -3 dB, 2 VRMS, 4 Ω	5 ÷ 70k Hz
S/N ratio @ A weighted, 1 V, Max Power	106 dBA
Damping factor @ 1 kHz, 2 VRMS, 4 Ω	100
Input sensitivity (two ranges)	0.3 ÷ 1.2 / 1.2 ÷ 4.8 VRMS
Input impedance (PRE IN)	15 kΩ
Load impedance (Min @ Dual Power Mode - Hi-Current)	
• 2 Ch	1 Ω
• 1 Ch	2 Ω

Output power (RMS) @ 14.4 VDC, 1% THD

Dual Power Mode - Hi-Current:	
• 2 Ch @ 4 Ω	300 W x 2
• 2 Ch @ 2 Ω	500 W x 2
• 2 Ch @ 1 Ω	750 W x 2
• 1 Ch @ 4 Ω	1000 W x 1
• 1 Ch @ 2 Ω	1500 W x 1
Dual Power Mode - A Class:	
• 2 Ch @ 4 Ω	80 W x 2

CEA Specifications

Output power @ 4 Ω, ≤ 1% THD+N, 14.4 V:	300 W x 2 Ch
SN ratio (ref. 1 W output)	80 dBA

Inputs / Outputs / Filters

Inputs	PRE / SP-DIF (Max 192 kHz/24 bit) OPTICAL and AD Link
Outputs	PRE Bypass / AD link
Filters	Removable kit (Hi-pass / Lo-pass / Band-pass 12/24 dB/oct) 32 steps 18 ÷ 7.5k Hz with 8 standard & 2 customizable modules

Size

B (Base) x L (Length) x H (Height) mm/inch	259 x 510 x 67 / 10 ^{n1/4} x 20 ^{n1/8} x 2 ^{n11/16}
Weight kg/lb	10.3 / 22.71

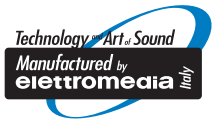

audison

www.audison.eu