

Technical Assistance

If you need assistance setting up or using your Gator product now or in the future, call Gator Support.
Australia

TEL: 03 – 8587 8898

FAX: 03 – 8587 8866

Mon-Fri 9am – 5pm AEST

Please retain this user guide for future reference.

If you would like to download a digital copy of this manual, or other Gator manuals/software, please visit the TDJ.com.au website and click 'Help/Downloads' for information on where to find the manuals/software.



People Movers



Vans (open cabin)



Sedans



Wagons



Buses



Truck



USER GUIDE

**WEATHERPROOF DAY & NIGHT
VISION CCD/CMOS CAMERA**

Model G50CC-G52CC



100% Waterproof & Anti-fog

Dimensions and definitions

Technical Parameters

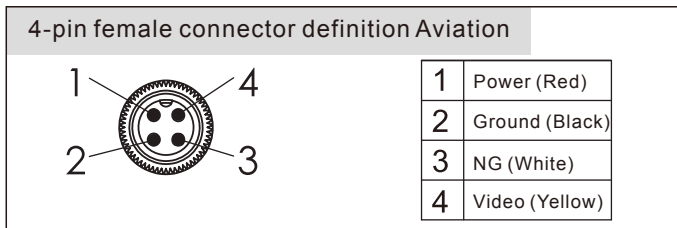
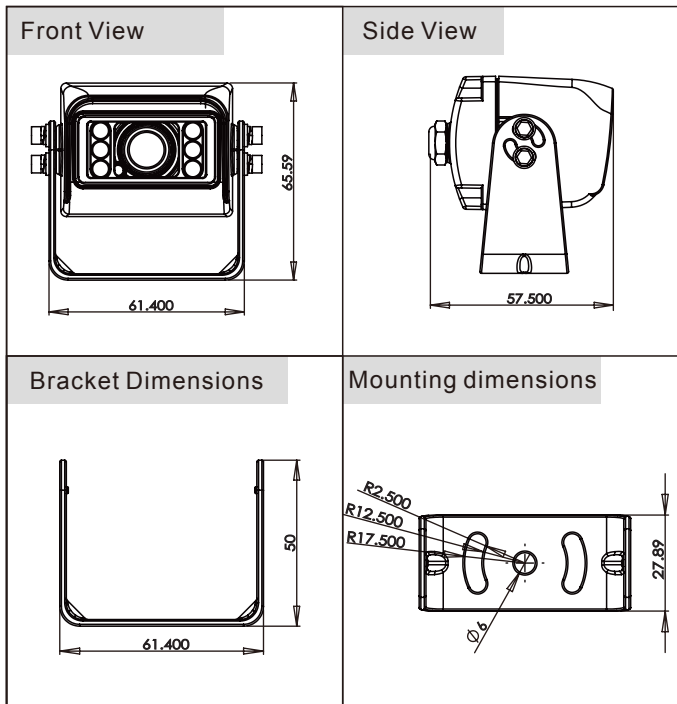

Specifications		
Product Type	G50CC	G52CC
Image Sensor	1/3 SONY	1/3 SONY
Horizontal resolution	PAL 976(H)X582(V)	PAL 976(H)X582(V)
	NTSC 976(H)X494(V)	NTSC 976(H)X494(V)
Resolution	700TVL	700TVL
Lens	2.9mm-16mm optional/F2.0(Iris)	2.9mm-16mm optional/F2.0(Iris)
Minimum illumination	0.1Lux/0Lux IR open	0.1Lux/0Lux IR open
Electronic Shutter	1/50 (1/60) - 1/10, 0000(sec)	1/50 (1/60) - 1/10, 0000(
Scanning System	Automatic	Automatic
SNR	≥48db	≥48db
Synchronous mode	Internal Synchronization	Internal Synchronization
Mirroring	Yes	No
Heating function	NG	NG
Operating Voltage	DC:12V	DC:12-24V
Video Output	1. 0p-p,75 Ω	1. 0p-p,75 Ω
Operating Temperature	-20°C, +60°C	-20°C, +60°C
Storage Temperature	-40°C, +70°C	-40°C, +70°C
Water level	IP69K	IP69K
Size	61.4mm(L)X57.5mm(W)X65.5mm(H)	61.4mm(L)X57.5mm(W)X65.5mm(H)
Weight	About 270g	About 270g

Design and specifications are subject to change without notice!