

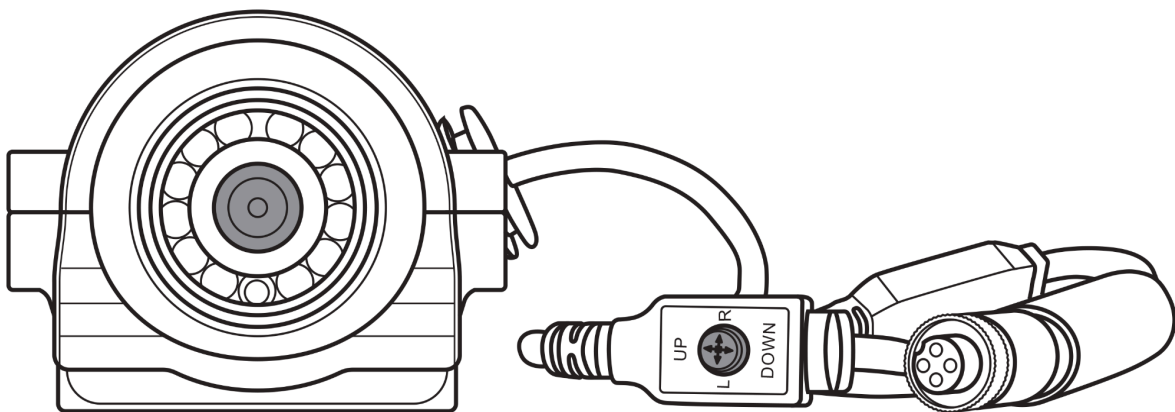

ADVANCED SAFETY **VISION SYSTEMS**

AVC11 HEAVY DUTY AHD 1080P SIDE Ai CAMERA

User Manual



AHD

12/24V
COMPATIBLE



Table of Contents

1. Introduction	page 2
2. Product Inclusions	page 2
3. Product Specifications	page 3
4. Installation Guide	page 3
o Safety Precautions	page 3
o Camera Viewing Angle and Orientation	page 4
o Camera Placement	page 4
o Wiring Instructions	page 5
o Maintenance and Care	page 5
5. Guideline Adjustment	page 6
6. Troubleshooting	page 7
7. Technical Support	page 8
8. Warranty and Support	page 9

Introduction

Thank you for choosing the Aerpro AVC11 Heavy Duty AHD 1080p Side Ai Camera. Aerpro Advanced Safety Vision Cameras are engineered to enhance driving safety by providing clear, high-quality images of the surrounding environment. Designed to minimise blind spots, these cameras improve situational awareness and assist with vehicle manoeuvring.

Before installing or using your Aerpro camera, please read this manual carefully to ensure proper setup and operation. Select a suitable mounting location based on your specific application, and before drilling, check for any wiring harnesses, hoses, or pipes behind the panel to prevent damage.

Product Inclusions

- Heavy Duty AHD 1080p Side Ai Camera with 50cm Cable (1)
- Self Tapping Mounting Screws (4)
- Camera Foam Pad (1)
- Jumperlink Connector (1) (720p/1080p switching)

Product Specifications

- **Model Number:** AVC11
- **Camera Type:** Heavy Duty Side Ai Camera (Surface)
- **Resolution:** 1080p Full AHD (Analog High Definition)
- **Viewing Angle Degree:**
 - Horizontal 185°
 - Vertical 45°
 - Diagonal 100°
- **Night Vision:** 12 IR LEDs for enhanced low-light performance
- **Waterproof Rating:** IP69K (superior water and dust protection)
- **Operating Voltage:** 12V/24V DC
- **Compatibility:** Suitable for various vehicles, including cars, trucks, buses, and more
- **Encapsulation:** Fully sealed design with a vibration rating of 5.9G for maximum durability

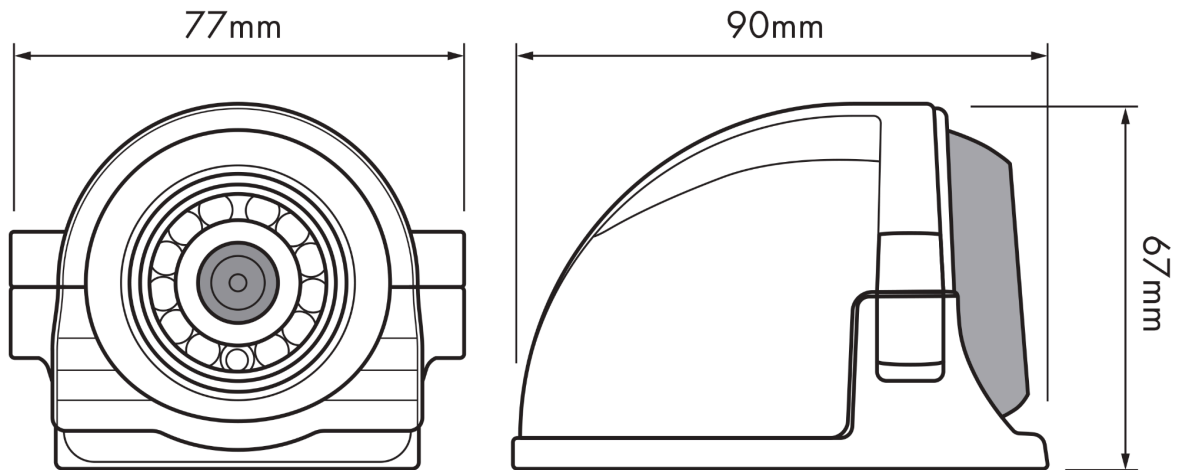

Installation Guide

Safety Precautions

- Ensure the vehicle is turned off before installation.
- Avoid installing the camera near high-temperature areas.
- Secure all cables properly to avoid interference with moving parts.

Camera Viewing Angle and Orientation

- The camera should be adjusted to provide a **85° (H) viewing angle** for optimal visibility.
- Avoid obstructions that may block the camera's field of view.
- Route cables along the vehicle's existing wire channels, where possible to, prevent damage.
- The correct orientation is determined by positioning the blue LDR Sensor towards the ground.

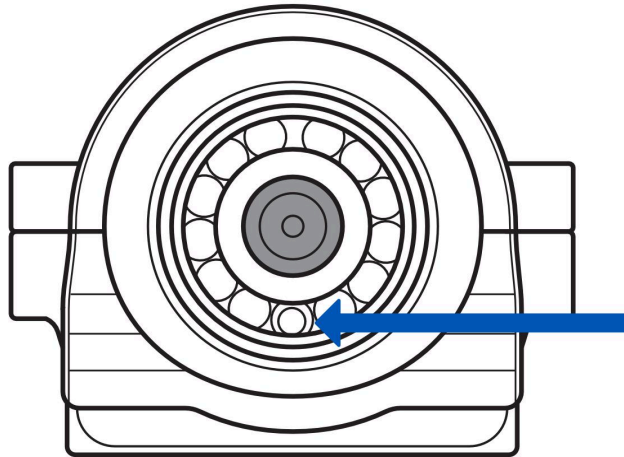

Camera Placement

- Mount the camera on the side or rear of the vehicle using the included side mount for an optimal view.
- Ensure the camera lens is angled properly to capture a full side or rear view.

Note: The correct orientation is determined by positioning the blue LDR Sensor towards the ground - refer to Camera Viewing Angle and Orientation above.

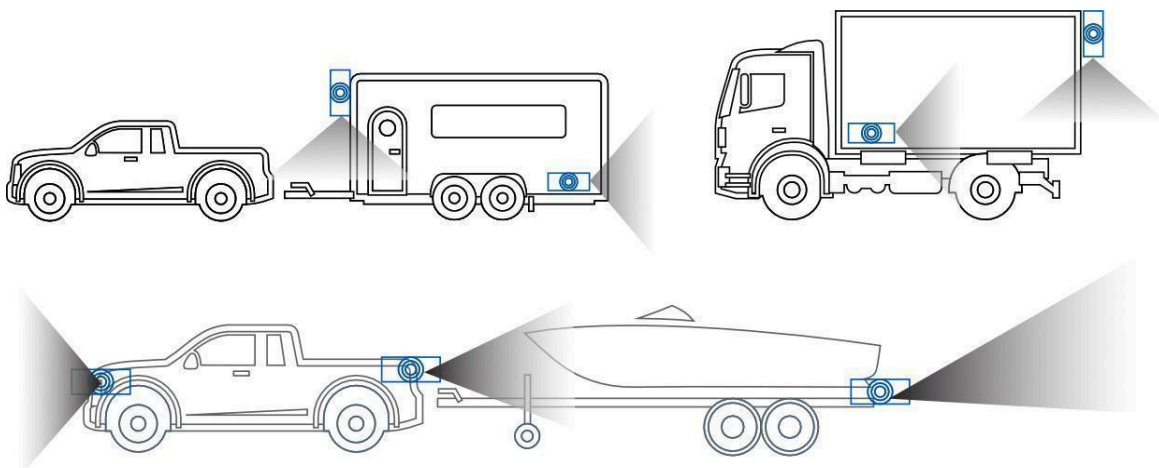

Note: Above images are examples of where the camera can be installed.

Wiring Instructions

1. Connect the power cable to the vehicle's power system (12V or 24V DC).
2. Route the video cable to the dashboard monitor.
3. Secure all connections and test the camera before finalizing installation.
4. Use cable clips to secure the wires and prevent loose connections.
5. Route cables along the vehicle's existing wire channels, where possible to, prevent damage.

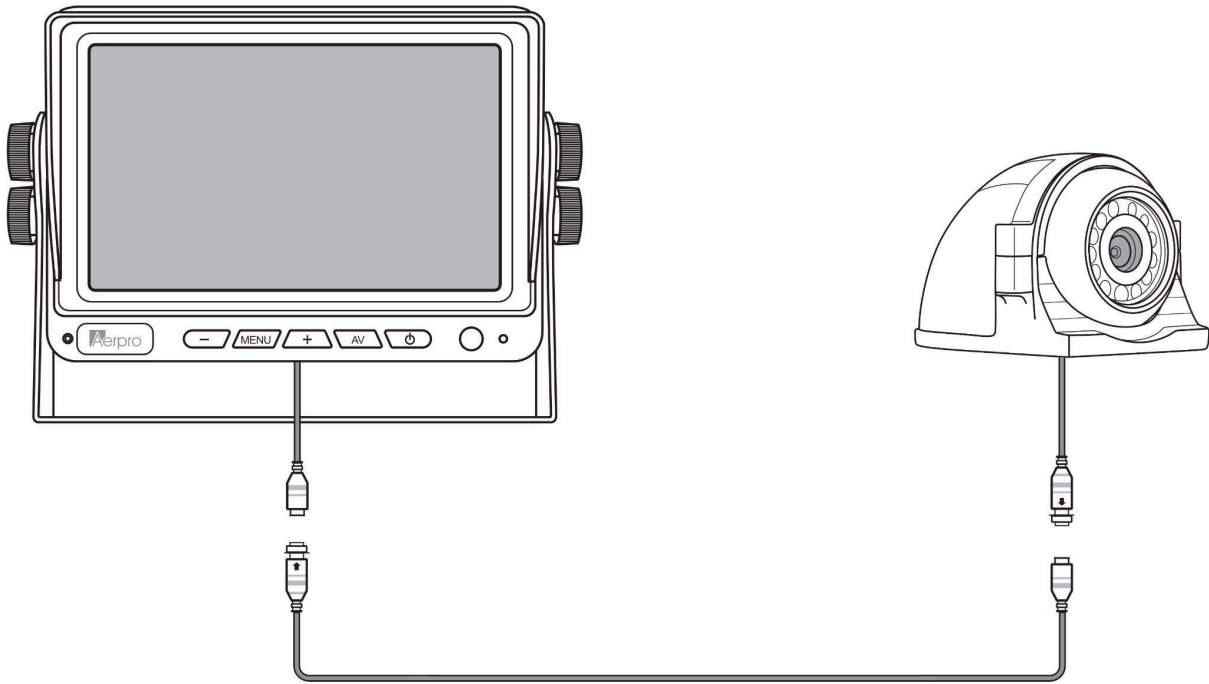

Note: This camera is supplied as a camera only with a 50cm cable. Extension cables and monitors are sold separately. The following wiring diagram illustrates the complete camera system.

Note: Extension cables available AVEC3, AVEC5, AVEC10, AVEC15 and AVEC20.

Maintenance & Care

- Regularly clean the camera lens for clear visibility.
- Avoid exposing the camera to excessive force or impact.
- Check and secure all wiring connections periodically.

Guideline Adjustment

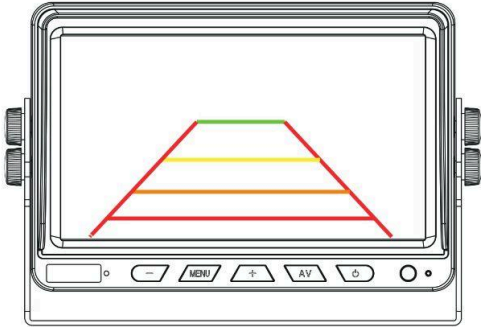
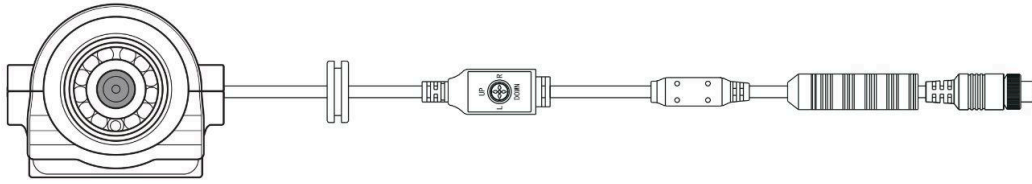

1. By default, the adjustment point is located in the lower left corner, as the white dot shown in the figure.

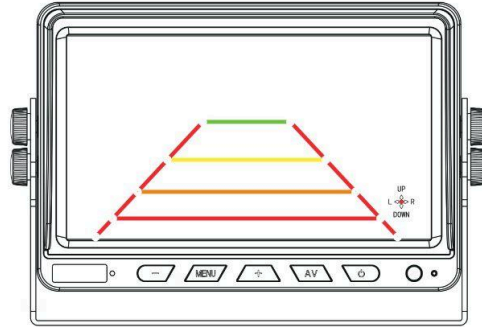

2. Press the Confirm key in the middle of the key and move it counterclockwise to the corresponding adjustment node, as the white dot shown in the above picture.

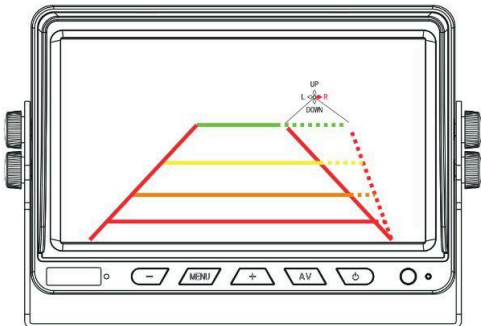

3. After moving the node to be adjusted, press up, down, left, or right to move the node, as shown in the figure, the node in the upper right corner is moved to the right, and the range of overlay line is widened.

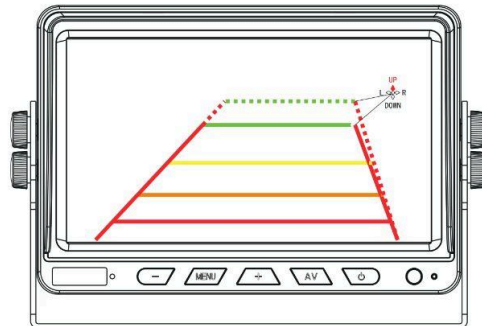

4. After moving the node to be adjusted, press up, down, left, or right to move the location, as shown in the figure, the node in the upper right corner moves upward and widens the range of overlay line.

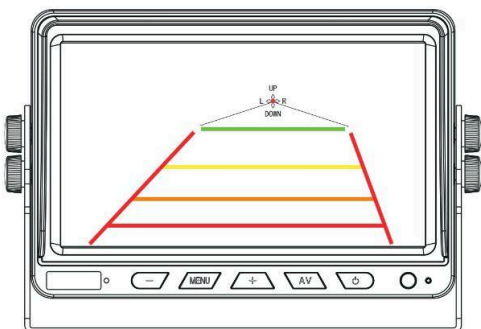

5. Press the middle confirm button to save the Settings after the adjustment finish. Note: If you do not press the confirm button after adjustment, the data will not be saved. After power off and restart, the data will return to the defaulted one.

Troubleshooting

Issue	Possible Cause	Solution
No image on the screen	Loose or disconnected wiring	Check and secure all wiring connections
	No 12volt blown fuse	Inspect and replace fuse if necessary
	Camera not operating	Test with another camera if possible
	Malfunctioning display	Test display with another input source
Flickering or distorted image	Loose connections	Tighten all connections
	Interference from other electronics	Keep wiring away from high-power cables
	Low voltage	Check battery and alternator output
Blurry or unclear image	Dirty camera lens	Clean the lens with a microfiber cloth
	Condensation inside lens	Allow to dry or replace camera
	Camera misalignment	Adjust camera angle
Blank screen with guidelines	No video signal	Check RCA or digital video connection
	Defective camera sensor	Refer to warranty terms for replacement
Camera works intermittently	Loose or corroded wiring	Inspect and repair connections
	Weak power supply	Test with direct battery connection
No night vision	IR LEDs not working (Functions only at night)	Refer to warranty terms for replacement
	Poor ground connection	Ensure solid ground wiring

Technical Support



If you need assistance setting up or using your Aerpro product now or in the future, call Aerpro Support Australia.

TEL: 03 – 8587 8898

FAX: 03 – 8587 8866

Mon-Fri 9am – 5pm AEST

Please retain this user guide for future reference.

This manual is considered correct at time of producing but is subject to change. For latest manuals and updates refer to the website: aerpro.com

Copyright © 2025 by TDJ Australia

All rights reserved. No part of this publication may be reproduced, distributed, or transmitted in any form or by any means, including photocopying, recording, copying or other electronic or mechanical methods, without the prior written permission of the author.

Warranty

Our goods come with guarantees that cannot be excluded under the Australian Consumer Law. You are entitled to a replacement or refund for a major failure and for compensation for any other reasonably foreseeable loss or damage. You are also entitled to have the goods repaired or replaced if the goods fail to be of acceptable quality and the failure does not amount to a major failure. This warranty is provided in addition to your rights under the Australian Consumer Law.

TDJ Australia Pty Ltd (Aerpro) warrants that this product is free from defects in material and workmanship for a period of 5 years from the date of purchase. This warranty is only valid where you have used the product in accordance with any recommendations or instructions provided by TDJ Australia Pty Ltd (Aerpro).

This warranty excludes defects resulting from alterations of the product, accident, misuse, abuse or neglect. In order to claim the warranty, you must return the product to the retailer from which it was purchased or if that retailer is part of a National network, a store within that chain, along with satisfactory proof of purchase. The retailer will then return the goods to TDJ Australia Pty Ltd (Aerpro).

TDJ Australia Pty Ltd (Aerpro) will repair, replace or refurbish the product at its discretion. The retailer will contact you when the product is ready for collection. All costs involved in claiming this warranty, including the cost of the retailer sending the product to TDJ Australia Pty Ltd (Aerpro), will be borne by you.

- This product comes with a **5-year limited warranty**.
- For support, visit our website or contact customer service at service@tdj.com.au

Thank you for choosing the Aerpro AVC11 Heavy Duty AHD 1080P Side Ai Camera. Drive safely!