

Aerpro®
BY UBSAN®

14+

APHUB X4

REAL TIME FPV



« User Manual Version 1.0 »

Read the User Manual and its instructions carefully before use!

Users may download the User Manual from the official AERPRO website.

WWW.AERPRODRONE.COM

APHUBX4 User Manual

Please fly the APHUBX4 in accordance with the directions given in this <User Manual>.

Important safety information

Operation: Be extremely careful and responsible when using the quad. Small electronic components can be damaged due to crashes or exposure to moisture/liquid. To avoid any injuries, do not use the quad with broken or damaged components.

Maintenance: Do not try to open or repair the units by yourself. Please contact AERPRO technical support for service. For more information, please visit the official website at www.aerpro-drones.com.

Battery: Do not disassemble, squeeze, impact, burn, drop or trample the battery. Do not short-circuit or put the battery terminal in contact with metal.

Do not expose the battery to temperatures above 60 ° C.

Charge the aircraft battery prior to flight. Use a Hubsan dedicated charger for charging. Keep the battery out of the reach of children and away from any kind of moisture.

Flight: Please be mindful of personal safety and the safety of others while flying.

- Do not fly the quad in crowded areas and always be aware of the safety of yourself and others.
- Do not fly in bad weather conditions.
- Do not attempt to catch the aircraft while it is in flight.
- This product is intended for experienced pilots over the age of 14.
- Keep your body away from the propellers after powered on. High speed propellers are very dangerous.
- After every flight, completely disarm the aircraft motors and disconnect the aircraft from power. Then, you may power off the remote control. Do not do so before at least disarming the aircraft motors! If the aircraft's motors are still running when you shut the remote control, the aircraft may engage its failsafe and attempt a Return to Home.

 Read the Disclaimer first before use.

Reading Tips

Symbol explanation



Prohibited Operation



Important Notice



Instruction



Explanation/Reference

Table of Contents

Important safety information	02	5.4 Battery installation	18
Reading Tips		5.5 Transmitter stick calibration (Mode 1 and Mode 2 throttle settings)	18
Symbol Explanation	02	5.6 Antennas	19
Usage Advice	02	5.7 How to set or change the 5.8GHz video frequency	19
Table of Contents	03	5.8 Binding the transmitter and aircraft	20
The APHUDX4 (H109S Standard) Profile		Getting Ready to Fly	
1 What's Included	04	6 Compass Calibration	21
2 Aircraft Overview	05	6.1 Compass Calibration	21
Pre-Flight Checklist		6.2 Horizontal Calibration	22
1 The Aircraft Battery	06	6.3 Rotational Calibration	22
1.1 Introduction	06	7 Arming/Disarming the motors	23
1.2 Battery installation	07	8 Basic Flight Operation	23
1.3 Charging the Battery	07	9 Advanced performance set up	25
2 Preparing the Aircraft		10 The Fail safes	27
2.1 Introduction	09	10.1 Low power	27
2.2 The Camera	09	10.2 Loss of flight control connection	27
2.3 The 1-axis Gimbal	12	10.3 Conditions that would trigger a failsafe	27
3 The Propellers		Frequently Asked Questions	28
3.1 Introduction	13	Technical assistance	29
3.2 Installation	13	Features & Specifications	30
3.3 Removal	14	Laws for drone flight (AUS)	31
3.4 Installing the Propeller Guards	14	Laws for drone flight (NZ)	32
4 Installing the Aircraft's 5.8GHz transmission antenna	15		
5 The H906A Remote Control/ Transmitter	15		
5.1 Introduction	15		
5.2 Getting to know the H906A	16		
5.3 H906A key functions	17		









The APHUDX4 (H109S Standard) Profile

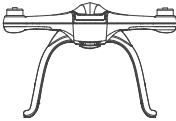

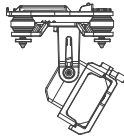



The APHUDX4 is a four-rotor quadcopter made for aerial photography and filmography. It comes equipped with a high-precision single-axis gimbal, 1080P HD camera and an advanced flight control system. The FPV remote control is capable of long-range flight while supplying real-time video transmission FPV. The APHUDX4 can also record video footage and take quality photos during flight.

 **FPV:** Also known as First Person View, or first-person perspective. With FPV, users may intuitively fly the aircraft and enjoy an immersive flight experience.

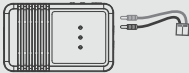
1 What's Included

Please check all items in the box before use.

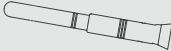
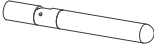
S/N	Name	Illustration	Qty	Description
1	Quadcopter		1	H109S Aircraft
2	Propellers		4	4 x Propeller A, 4 x Propeller B
3	The 1-Axis Gimbal		1	A single axis gimbal
4	Propeller wrench		1	Used to install and remove propellers
5	Transmitter		1	H906A remote control (batteries not included)
6	AC power adapter		1	A 110-240v adapter
7	11.1V LiPo battery		1	The aircraft battery
8	Protection guard		4	Protects the propellers (includes 4 guards, 4 screws)
9	Transmitter sunshield		1	Reduces glare from the H906A video screen

10	Balance Charger		1	Used to charge the aircraft battery
11	Micro-USB camera cable		1	Used to read camera data; also used to charge the camera battery
12	User Manual		1	The Hubsan X4 PRO User Manual
13	1080P Camera		1	An HD camera
14	2.4GHz transmission antenna		1	The transmitter's 2.4GHz transmission antenna
15	5.8GHz transmission antenna		1	The aircraft's 5.8GHz transmission antenna
16	5.8GHz receiving antenna		1	The transmitter's 5.8GHz receiving antenna

2 Aircraft Overview

The APHUDX4 comprises the aircraft, its camera, gimbal, propeller guards, power system, flight control system and transmission system (remote control). The flight control system is built into the aircraft itself.

Transmission system features	External aircraft features	Aircraft flight modes
------------------------------	----------------------------	-----------------------

Bidirectional data transmission
FPV/Video transmission

The 1-axis gimbal
The camera
The smartphone gimbal
Protection guard

Altitude Hold mode
GPS Hold mode
(aka the GPS position hold feature)
Return to Home mode
Follow Me mode
Orbit mode
Headless mode

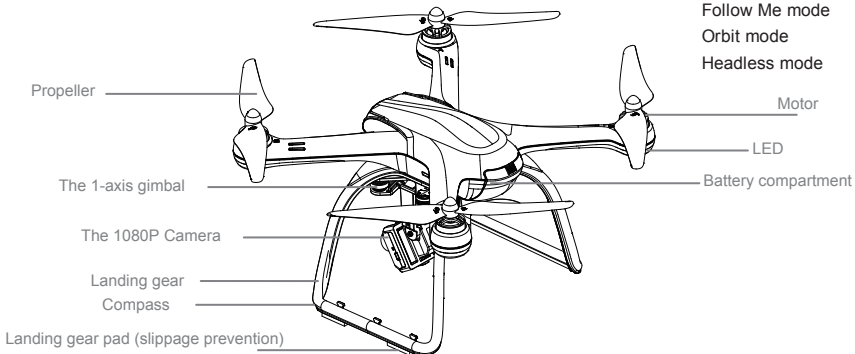

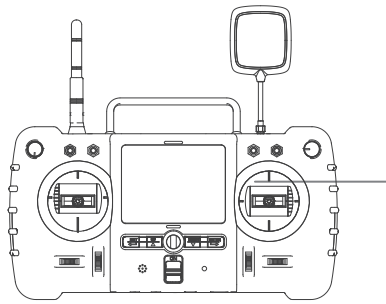

The H906A transmitter
(uses 8 AA batteries or a
LiPo battery- not included)

Pre-Flight Checklist

Please refer to the following installation and preparation steps before using the aircraft.

- ⚠ • Before flight, check that the remote control and aircraft have sufficient power to fly.
- Check the drone fuselage and propellers carefully. Broken or failed parts may cause dangerous malfunctions.
- Check that the battery is securely connected to the aircraft. Loose connections may be shaken by intense flight and in-flight vibrations, which may lead to accidental disconnection and loss of power during use.
- First power the transmitter on, then the aircraft. After use, first disconnect the aircraft from its battery- then power off the transmitter. Incorrect operations preflight and inflight may cause flight malfunction, failure and damage.

1 The Aircraft Battery

Before using the APHUDX4, please verify that the battery is sufficiently charged.

Device	Power supply
Transmitter	8 AA Batteries or a LiPo (2 or 3 cell)
Camera	3.7V 650mAh rechargeable LiPo battery (included)
Aircraft (including the gimbal)	The 11.1v 7000mAh aircraft battery powers both aircraft and gimbal

The following is an overview of how to use and charge the aircraft battery.

1.1 Introduction

The quadcopter battery is a rechargeable Li-Po battery rated at 11.1V and has a 7000mAh capacity. Be sure to use a Hubsan dedicated charger for charging. Fully charge the battery before flight.

Battery specifications

Type: Li-Po battery

Capacity 11.1V 7000mAh

Ambient temperature for charging 0°C~40°C

Ambient temperature for use - 20°C~50°C

Environmental humidity for charging and use < 80%

1.2 Battery installation and use

Power on/power off

Power on: Push the battery into its compartment and connect the bullet adapters as shown in the below figure. Note the positive and negative polarities. The aircraft's LEDs should light up.

Power off: Disconnect the battery adapters to power off the aircraft.

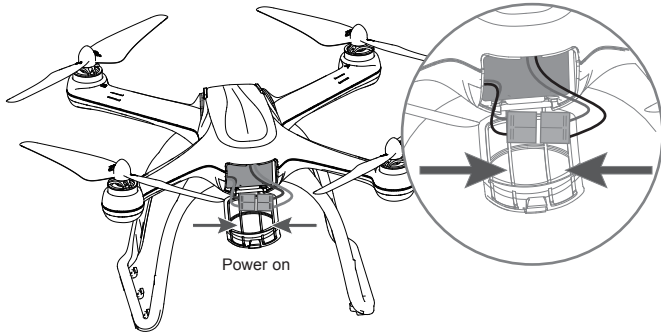

Checking power levels

If the drone and transmitter are successfully paired, users may view power levels for both the transmitter and drone on the remote control screen.

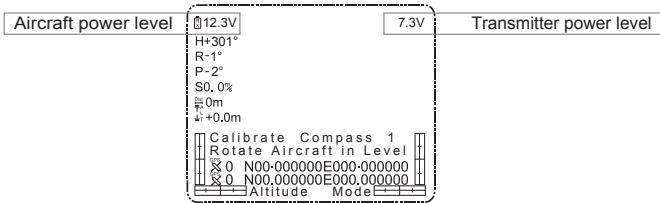

1.3 Charging the Battery

- 1) Connect the balance charger to the AC power adapter (100-240 V, 50/60Hz; if necessary, use a power conversion plug). The balance charger LEDs will flash green, indicating that it is on standby (as shown below).
- 2) Remove the battery from the aircraft and connect the battery to the balance charger.
- 3) The charger LEDs will turn a solid red to indicate charging in process.
- 4) When the balance charger LEDs turn solid green, charging is complete. Please remove the battery from the charger.

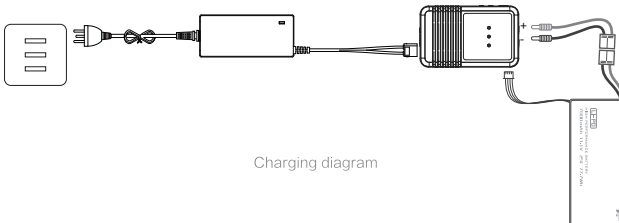

Charging diagram



(1) Overcharge protection : When the battery voltage level reaches 12.8V, the battery will stop charging. Excessive charging will seriously damage the battery.

(2) Over-discharge protection : When the battery voltage level reaches 8.4V, the battery will stop outputting power. Excessive discharging will seriously damage the battery.

(3) Short-circuit protection : When the battery detects a short-circuit, it will stop outputting power to protect itself.

Safety Advisory Notice for Lithium-Polymer (LIPO) Batteries

LiPo batteries are different from conventional batteries in that their chemical contents are encased in a relatively lightweight foil packaging. This has the advantage of significantly reducing their weight but it does make them more susceptible to damage if roughly or inappropriately handled. As with all batteries, there is a risk of fire or explosion if safety practices are ignored:

- If you do not plan to fly the quad for a long time, store the battery 50% charged to maintain battery performance and life.



- Please use Hubsan chargers for battery charging.
- Discharge the battery at 5C current or below. To avoid discharge related battery damage, do not prolong the discharge time.
- Do not charge on carpet to avoid fire.
- Batteries need to be recharged if unused for over 3 months.



1. Do not disassemble or reassemble the battery.
 2. Do not short-circuit the battery.
 3. Do not use or charge near sources of heat.
 4. Do not put the battery in contact with water or any kind of liquid.
 5. Do not expose the battery to direct fire or sunlight.
 6. Do not puncture or subject the battery to force of any kind.
 7. Do not throw or manhandle the battery.
 8. Never charge a battery that has been damaged, become deformed or swelled.
 9. Do not solder on or near the battery.
 10. Do not overcharge or over discharge the battery.
 11. Do not reverse charge or reverse the battery polarities.
 12. Do not connect the battery to a car charger/cigarette lighter or any other kind of unconventional power source.
 13. This battery is prohibited for non-designated devices.
 14. Do not touch any kind of liquid waste or byproduct from batteries. If skin or clothes come in contact with these substances, please flush with water!
 15. Do not mix other types of batteries with lithium batteries.
 16. Do not exceed the specified charging time.
 17. Do not place the battery in a microwave or in areas of high pressure.
 18. Do not expose the battery to the sun.
 19. Do not use in environments with high static electricity (64V and above).
 20. Do not use or charge in temperatures below 0 and above 45 .
 21. If a newly purchased battery is used, leaking, possesses a bad smell or any other abnormality, return immediately to the vendor.
 22. Keep away from the reach of children.
 23. Use a dedicated battery charger and follow all charging requirements.
 24. Minors who use the battery and its dedicated unit must be supervised by an adult at all times.
-

2 Preparing the Aircraft

The APHUDX4 comprises four motors, a single-axis gimbal, 1080P HD camera and an advanced flight control system. The aircraft is equipped with data and video transmission capabilities for user-friendly flight.

2.1 Introduction

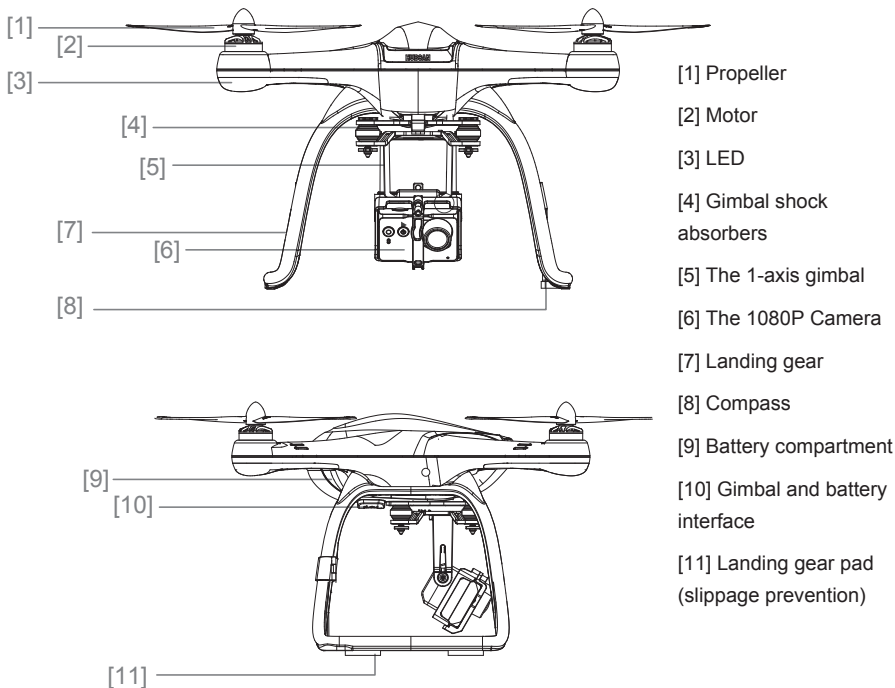

2.1.1 Flight control system overview

The APHUDX4 is an aircraft with nimble handling and excellent stability. Its flight system features multiple GPS features, two fail safes, low power warnings and other functions.

Flight control system components

The motherboard: Also known as the mind and heart of the aircraft, the motherboard connects and controls the aircraft's main functional hardware.

IMU : The aircraft uses the IMU (inertial measurement unit) to determine and control its position and height in the air and on the ground.

GPS and compass : The GPS and compass direct aircraft positioning/navigation when GPS functions are in use.

The LEDs : These indicators signal the current status of the flight control system.

2.2 The Camera

Install the camera battery and secure the camera to its gimbal. After powering on the aircraft, press the camera's power button to turn it on. Users may then use the transmitter's camera and video function keys to take pictures and record video.

Camera specifications			
Video resolution	1920*1080 HD	Battery	3.7V 650mAh
Recording frame rate	30FPS	Ambient operational temperature	10~+70 degrees Celsius
Video format	MOV	Ambient operational humidity	30%~80%
Video format	3 million pixels MJPG	Power consumption (operational)	1.9W
Resolution	2048 * 1536 pixels	Power consumption (standby)	1.33W
Lens specifications	1/3"	Ambient storage temperature	- 40~+125 degrees Celsius
Lens viewing angle	170 degrees (MAX)	Ambient storage humidity	30%-90%

2.2.1 Camera function overview

Power on/off: Short press the Power button (<2 seconds) once to power the camera on. Long press (≥ 2 seconds) the Power button to power off.
Video recording: Short press the record button (<2 seconds) once to start recording video. Press the record button again to stop the recording.

Note: The H906A transmitter is also used for photography, video recording and playback. For more information, refer to the "H906A key functions" section on page 17.

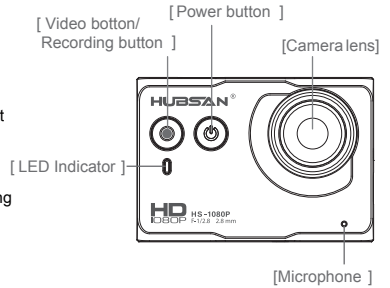

2.2.2 The Micro-SD card slot

Before using the APHUDX4 to take pictures or videos, please insert the Micro-SD card into the card slot (as shown on the right) when the camera is turned off.

- A Micro-SD is not provided with the APHUDX4. Users must provide or purchase a Micro-SD that is class 4 or above (recommended class 6) and possesses between 4-32GB of memory. Format the Micro-SD to FAT32 before using it.
- Be sure to format the Micro-SD to FAT32 before use. Verify that the allocation unit size is set to 32 kilobytes- or the camera will be unable to register the Micro-SD.

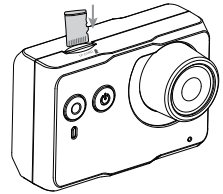

2.2.3 The Micro-USB camera cable

When the camera is powered on, users may connect the camera to a PC with the provided Micro-USB cable to view pictures and videos if a Micro-SD is in use. The camera battery will be charging at the same time.

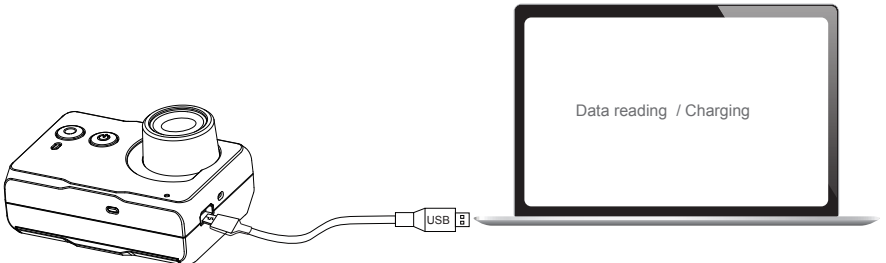

- ⚠ If the camera is connected to a computer via the Micro-USB, the former must be powered on to copy videos and pictures to the PC. If the camera is powered off, media cannot be transferred (only the battery will charge).
- If the camera's USB connection to the aircraft is disconnected, any video recordings will be terminated. Under any other conditions (i.e. when the camera is connected to the computer, or when the camera is connected to the aircraft but not recording), the camera will simply power off.
- The camera may also charge if it is connected to the aircraft.

2.2.4 The Camera's Status Indicator

When the camera is powered on, its status indicator will light up. Users may determine the camera's status by watching the indicator's light patterns.

Camera status indicator	Camera status
Solid blue (no red)	Camera is on standby mode
Solid blue with a red light flashing every second	Camera is recording video
Solid blue and solid red	Camera has encountered a failure or malfunction
Blue light (no red) flashing every second	Micro-SD is full/no card sensed in the camera/there is a problem with the Micro-SD in use
Blue light (no red) flashing rapidly	Micro-SD is full
Red light (no blue) flashing rapidly	Low power (battery)

2.2.5 Installing the camera

- Unscrew the camera fixture frame from its position on the camera gimbal.
- Install the camera facing outwards and refasten the camera fixture frame with its provided screws.
- Plug the FPV transmission cable's Micro-USB end into the camera's Micro-USB socket. Insert the cable's other end to the input board on the belly of the aircraft.

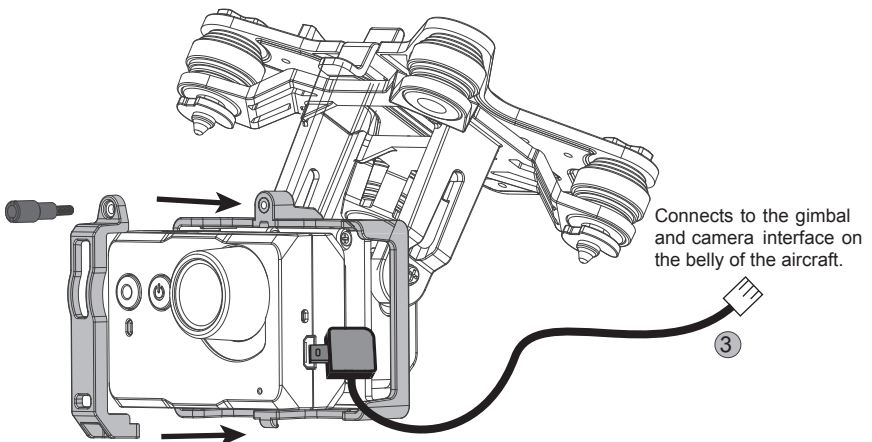

2.3 The 1-axis gimbal

After the gimbal and camera are installed and the aircraft powered on, the gimbal will also power on and test itself for issues. The gimbal's movement (pitch) may be controlled by the H906A transmitter/remote control.

Gimbal features	
Precision of control	$\pm 0.03^\circ$
Range of motion	Pitch: $+80^\circ$ to -50°
Stability features	Shock absorbers+ software stabilization

2.3.1 Installing the 1-axis gimbal

1) With the back of the camera facing the rear of the aircraft, align the gimbal's frame with the belly of the aircraft. Slide the gimbal horizontally onto the drone.

2) Plug the gimbal's signal transmission line to the gimbal and camera interface as shown in the figure below.

3) Plug the camera's FPV transmission cable to the left of the gimbal's signal transmission cable as shown in the figure below.

The gimbal signal line should be inserted with brown wire matching the negative polarity. If the gimbal does not move after every line has been plugged in, please check to see if the gimbal line has been installed backwards.

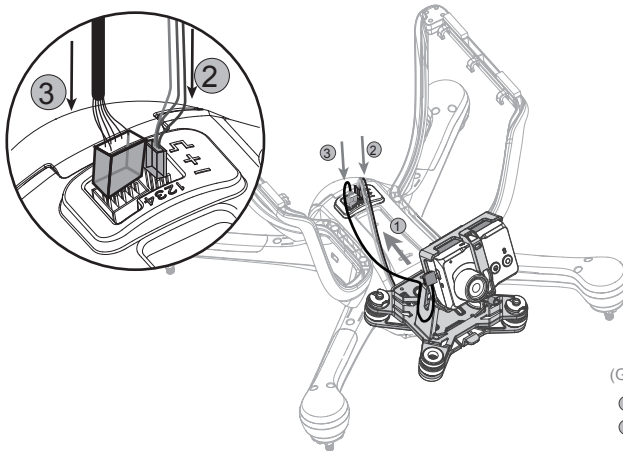

(Gimbal installation diagram)

- ② Gimbal signal transmission line
- ③ Camera FPV transmission cable



2.3.2 Checking gimbal operation and handling



- ⚠ • Anomalies in the gimbal's movement may manifest if the aircraft is placed on uneven ground/grass and the gimbal runs into foreign objects present. This may also happen if the gimbal experiences excessive external movement/force (being hit or broken). Please make sure the aircraft is on flat, open ground before taking off; do not move or disturb the gimbal while taking off.
- Flying in fog or in cloud cover will most likely cause condensation on the gimbal and camera. If this occurs, simply wipe the units dry with a soft cloth.

3 The Propellers



The APHUDX4 uses 9-inch propellers. Each is marked with either an A or a B. Please replace damaged propellers. Before installing the propellers for the first time, please check whether the propeller and motor arm read "A" or "B". The two letters should match.

3.1 Introduction

Propeller	Propeller A	Propeller B
Illustration		
Installation	Use only with an "A" motor	Use only with a "B" motor

	
---	---

Symbol explanation

-  Lock: symbolizes the direction in which the propeller is tightened.
-  Unlock: symbolizes the direction which the propeller is loosened.

3.2 Installation

- 1) Before installing the propellers, please check to make sure that all letters on the propellers match the letters on the motor arms. Propeller A's go with A motors and propellers B's go with B motors.
- 2) Mount all 4 propellers on their motors (A to A motors, B to B motors). Turn each propeller in the indicated "lock" direction. Propellers should be firmly (but not overly) secured to their motor shafts.

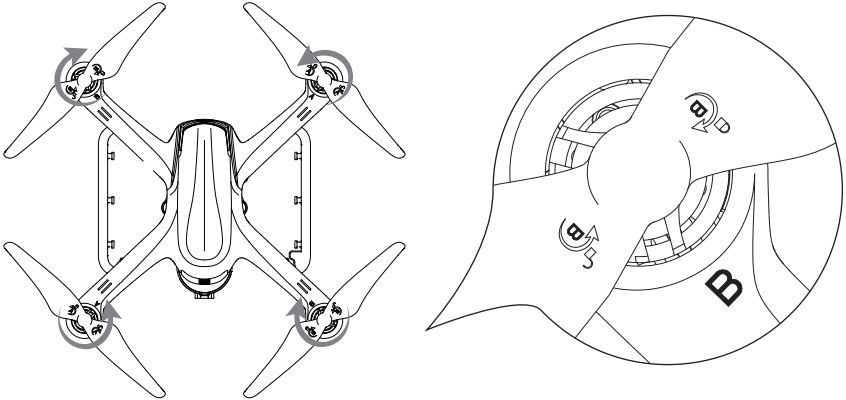

-  The propellers are self-tightening units. Please do not use other screws or screw glue to attach them to the motor shafts.
- Make sure that the propellers are installed in the correct positions, otherwise the aircraft will not be able to fly normally.
- Since the propeller blades are thin and somewhat sharp, it is recommended that users wear gloves during installation to prevent accidental scratches.

3.3 Removal

When the blade is damaged or needs to be replaced, hold the propeller with a hand or the provided auxiliary wrench, and remove by turning it in the indicated "unlock" direction.

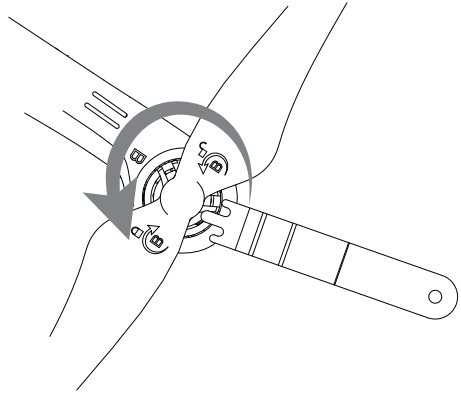

-
-  • Check that the propeller is installed correctly and securely before each flight.
- Before each flight, be sure to check that all propellers are free of deformations and undamaged. If any propeller is damaged, please replace before flying.
 - Keep away from active motors and propellers to avoid injury.
 - Please use genuine Hubsan propellers to ensure optimum flight performance.
-

3.4 Installing the Propeller Guards

It is recommended that beginners use the APHUDX4 propeller guards for flight safety while flying.

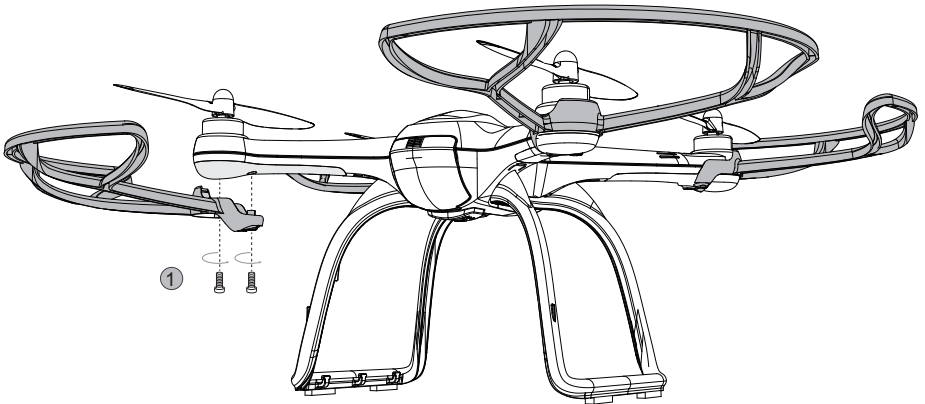

-
-  • Remove the existing fuselage screws first. Use the longer propeller guard screws provided to then install the propeller guards. (Note: The propeller guard screws and assembly/disassembly tools needed are located in the box housing the guards themselves.)
- Please note the distinction between A propeller guards and B propeller guards during installation. Guards must be matched with the appropriate motors (A to A, B to B), or installation will be impossible.
-

4 Installing the Aircraft's 5.8GHz transmission antenna

Remove the antenna from its wrappings and locate the gold SMA connector at the side of the unit. Attach the antenna to the connector by screwing it on clockwise. After securely tightening the antenna, bend it at the joint to point it downwards.

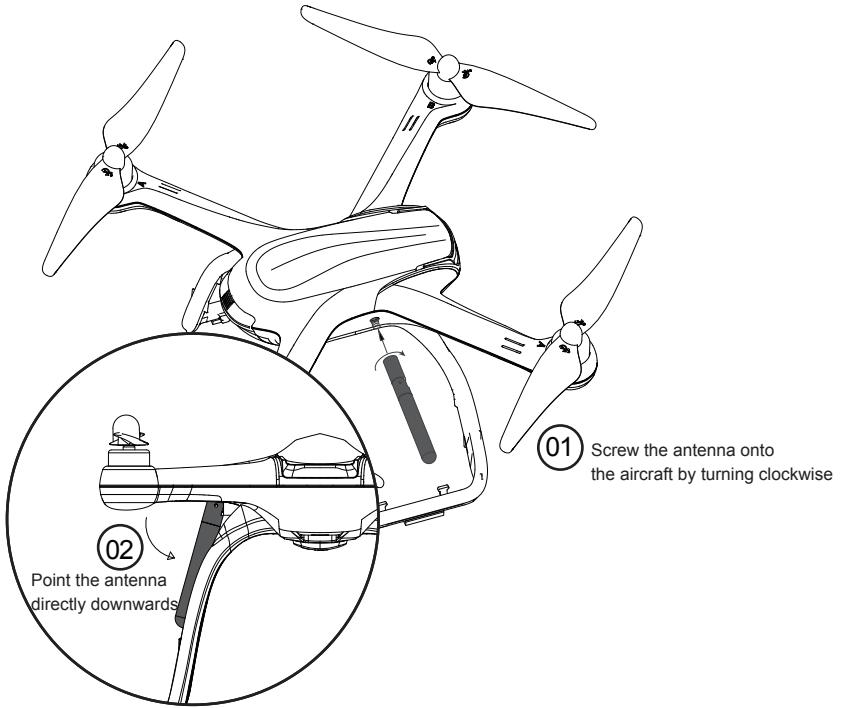

5 The H906A Remote Control/Transmitter

5.1 Introduction

5.1.1 Main interface

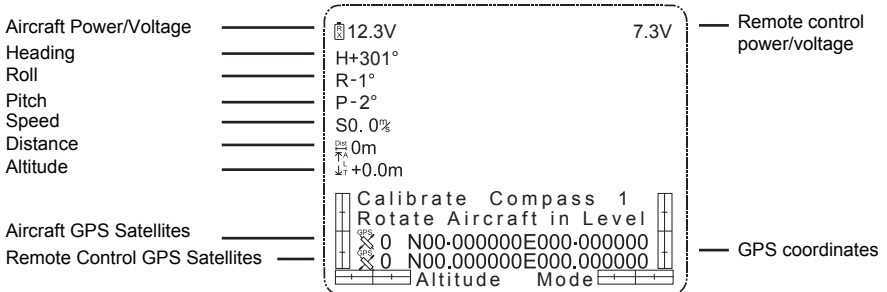

5.2 Getting to know the H906A

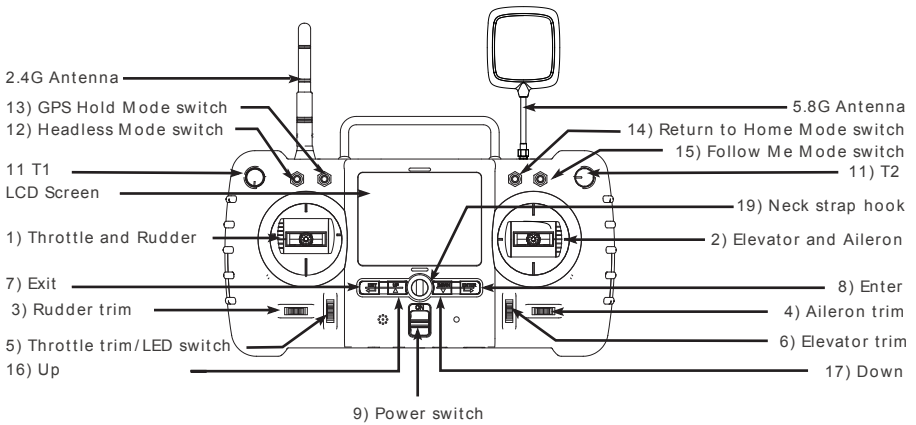

Mode 2 (American Hand)

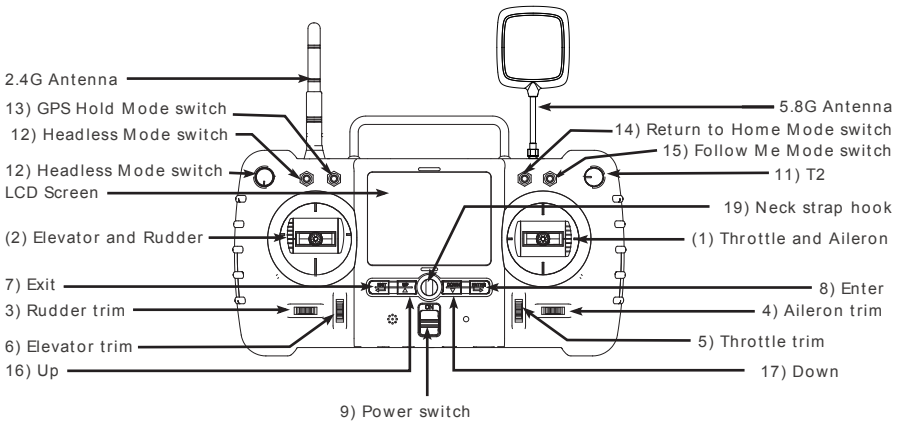

Mode 1 (Japanese Hand)

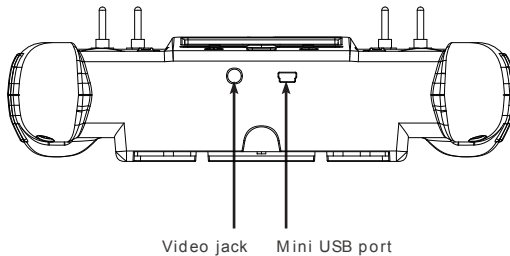

5.3 H906A key functions

S/N	Key/Switch	Function
1	Throttle/Rudder stick	Push the stick forward or backward and the quadcopter will ascend or descend (respectively). Push the stick left or right and the quadcopter will rotate counterclockwise or clockwise (respectively).
2	Elevator/Aileron stick	Push the stick forward or backward and the quadcopter will fly forwards or backwards (respectively). Push the stick left or right and the quadcopter will fly left or right (respectively).
(1)	Throttle/Aileron stick	Push the stick forward or backward and the quadcopter will ascend or descend (respectively). Push the stick left or right and the quadcopter will fly left or right (respectively).
(2)	Elevator/Rudder stick	Push the stick forward or backward and the quadcopter will fly forwards or backwards (respectively). Push the stick left or right and the quadcopter will rotate counterclockwise or clockwise (respectively).
3	Rudder trim	Use the Rudder trim to adjust for counterclockwise and clockwise rotation/yaw drift.
4	Aileron trim	Use the Aileron trim to adjust for left and right horizontal drift.
5	Throttle trim	Throttle trim is normally centered. If the throttle channel is not centered, use the Throttle trim to adjust.
6	Elevator trim	Use the Elevator trim to adjust for forward and backward drift.
7	Exit	Long press to exit the Main Menu. Short press to take photos/start and end video recordings. When in Playback mode, short press to browse/play the photos and videos taken prior.
8	Enter	Used to enter the Main Menu when the user holds the throttle to its most downward position and while doing so long presses the Enter key. Short press to move amongst the Photo/Video/Playback modes.
9	Power switch	Push up/ON to turn on the transmitter. Push down/OFF to turn off.
10	Orbit mode	Long press the Down key to use Orbit mode. The aircraft must be at least 5m away.
11	T1, T2	T1 and T2 correspond respectively to channels 1 and 2 on the bottom of the aircraft.
12	Headless mode switch	Flip the switch up to enter Headless Mode. Flip down to exit Headless Mode.
13	GPS Hold mode switch	Flip the switch up to activate GPS function. Flip down to deactivate GPS function.
14	Return to Home mode switch	Flip the switch up to activate Return to Home Mode. Flip down to exit Return to Home Mode.
15	Follow Me mode switch	Flip the switch up to activate the Follow Me function.
16	UP	Used to navigate the Main Menu. Also used to set a new center for Orbit mode (short press once).
17	Down	Used to navigate the Main Menu. Also used to enter/exit Orbit mode (long press once to enter or exit). To enter RSSI mode, hold the Down key and then power the transmitter on while doing so.

5.4 Battery installation

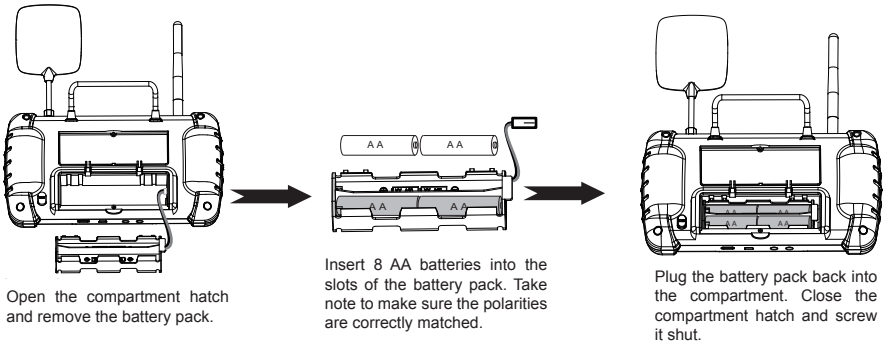

- Do not mix new and old batteries
- Do not use a discharged battery
- Do not cross-use different types of batteries at the same time

5.5 Transmitter stick calibration (Mode 1 and Mode 2 throttle settings)

Mode 1: Push the left stick to the upper left corner and the right stick to the upper right corner. Power the transmitter on while holding both sticks in their respective positions; the LCD screen will show "Calibrate Sticks Mode 2". Let go of the sticks, then pull them up, down, towards the center and outwards. Repeat this sequence 3 times, then release both sticks and hold the "Exit" key until the transmitter beeps. This indicates a successful calibration.

Mode 2: Push both sticks to the upper left corners. Power the transmitter on while holding both sticks in their respective positions; the LCD screen will show "Calibrate Sticks Mode 2". Let go of the sticks, then pull them up, down, towards the center and outwards. Repeat this sequence 3 times, then release both sticks and hold the "Exit" key until the transmitter beeps. This indicates a successful calibration.

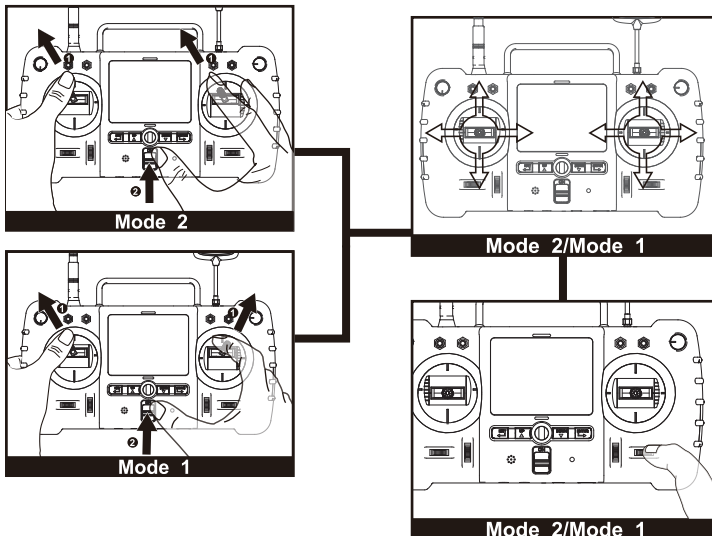

5.6 Antennas

To keep video transmission clear and avoid interference, make sure the H906A's 5.8Ghz antenna logo faces the aircraft. During flight, the antenna and its signal path must be unobstructed to maximize the video and control range. Bend the antenna so that its logo is as directly pointed towards the aircraft as possible.

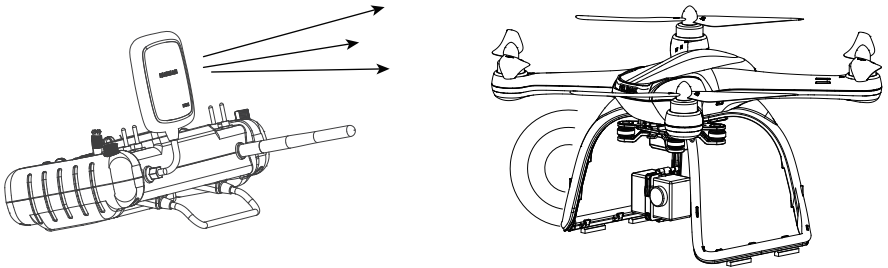

Failure to keep the antenna's logo unobstructed and pointing towards the aircraft may lead to poor video transmission.

5.7 How to set or change the 5.8GHz video frequency

The transmitter will automatically find the best frequency to ensure a good quality live video. If desired or needed, users may manually search the 5.725-5.945GHz frequencies for a better video transmission signal.

To adjust the 5.8GHz frequency, first pull and hold the throttle stick downwards to the very bottom of its socket. While doing so, long press the "Enter" key to enter the Main Menu. Use the Up/Down keys and scroll to the "5.8G frequency" selection. Press "Enter" to enter the frequency menu; use the Up and Down keys to browse the different frequencies. Long press the "Exit" key for 2 seconds to save the new frequency setting and exit.

```
12.2V                               7.2V

Set reverse      +
Set sensitive    +
Manual mode      OFF
Expert mode      YES
Stick mode       1
>5.8G frequency
Fly when no GPS  NO
Show Version
```

Getting ready to fly

It is recommended that users implement some kind of flight training (i.e using a simulator for flight practice, seeking professional guidance, etc.) before flying the H109S. Please select an appropriate flight environment for flight.

Flight environment requirements

- (1) Select an open environment devoid of high rise buildings and tall obstructions (such as trees and poles). Near buildings and obstacles, flight control signals and GPS signals can be severely weakened; GPS functions such as GPS mode and Return to Home may not function properly.
- (2) Do not fly in bad weather conditions (such as in wind, rain, fog, etc).
- (3) When flying, please stay away from obstructions, crowds, high voltage lines, trees, water, etc.
- (4) To avoid remote control signals interference, do not fly in complex electromagnetic environments (such as venues with radio stations, power plants and towers).
- (5) The APHUDX4 cannot be used in or near the Arctic circle or Antarctica.
- (6) Do not fly in restricted areas or no-fly zones.
- (7) Do not operate the aircraft near high pressure lines, airports or areas with severe magnetic interference.



High pressure lines

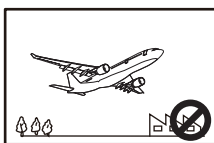

Airports

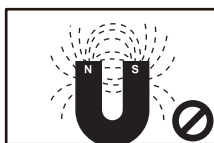

Magnetic interference



Rain

Pre-Flight checklist

- 1) Make sure the aircraft battery and mobile device are charged and have adequate power.
- 2) Confirm that propellers are properly installed.
- 3) Check that the gimbal is properly installed and that all lines are inserted into the correct sockets.
- 4) If one is taking pictures, insert the Micro-SD card required for taking pictures and videos.
- 5) After powering on the aircraft and transmitter, see that the gimbal and camera are operating normally.
- 6) Verify that the motors arm and spin smoothly.

5.8 Binding the transmitter and aircraft

Only use this process if the aircraft and transmitter are not pairing automatically when powered on, or to reset the 2.4GHz flight control and 5.8GHz video transmission connections! The binding process is usually completed in the factory. If you replace either the remote or the aircraft, the two will need to be re-bound to each other.

- 1) Hold the "Enter" key and power on the transmitter until "System Initialize" appears on the LCD screen.
- 2) Release the Enter key when the screen changes to display "Bind to Plane".
- 3) Power on the quad and place it very close to the transmitter. After a few seconds, the transmitter should then beep, indicating that binding has been successful.
- 4) If this does not happen and the aircraft's LEDs begin to rotate clockwise, the binding is unsuccessful. Please power off the quad and repeat the above steps.

7.1V

Bind to Plane

6 Compass Calibration

Every time the aircraft is powered on, its compass will automatically test for deviations in the local magnetic field. If deviations are detected, the aircraft will automatically enter compass calibration mode. The remote control screen will first read "Calib compass 1" and the LEDs should be red, flashing clockwise. Slowly rotate the aircraft on the horizontal plane until the aircraft LEDs change color. The remote control screen will then read "Calib compass 2" and the LEDs should be green, flashing alternately in vertical pairs. Point the head of the aircraft downwards and rotate the aircraft in place. When the "Calib compass 2" disappears from the screen and the LEDs begin to flash simultaneously, calibration is complete.

If the H telemetry symbol (which indicates what direction the aircraft is pointing towards) after the initial compass calibration is still unstable and inaccurate, users may also manually enter compass calibration by following the steps below.

- ⊗ Do not calibrate the compass in areas with strong magnetic interference.
- Do not carry ferromagnetic materials while calibrating the compass, such as keys, cell phones, etc.
- Do not calibrate near large pieces of metal or large metal structures.

6.1 Calibration steps

Hold the throttle to the left side of its socket. While doing so, rapidly wiggle the right stick left and right continuously. "Calib compass 1" should appear on the screen. All 4 LED indicators should be flashing red in a clockwise pattern; rotate the X4 clockwise on the horizontal plane until the LCD screen says "Calib compass 2". Point the X4 nose down (the aircraft should be perpendicular to the ground) and rotate it clockwise until "Calib compass 2" disappears.

When the "Calib compass 2" disappears from the screen and the LEDs begin to flash simultaneously, calibration is complete.

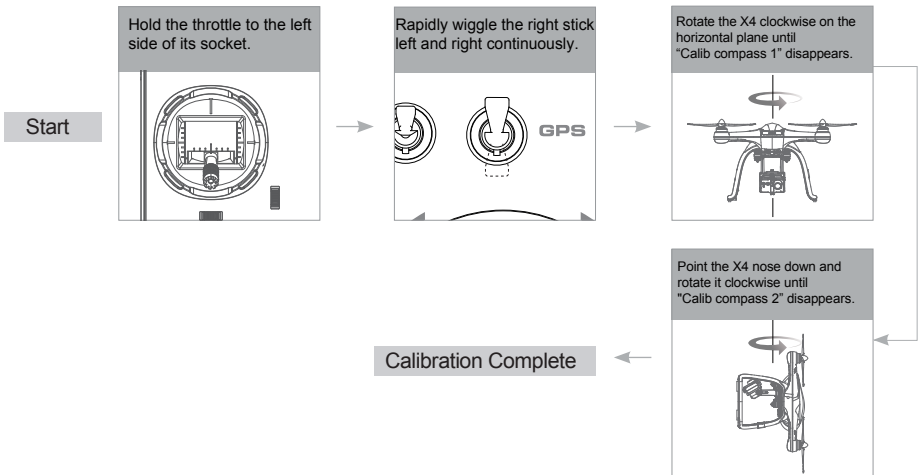

6.2 Horizontal calibration (also known as Gyro calibration)

Horizontal calibration is required when the quadcopter drifts on the horizontal plane during flight. When this happens, land the aircraft and disarm its motors.

Place the aircraft on a completely flat surface and then follow the below calibration procedure.

Hold the left stick to the right side of its socket. Rapidly wiggle the right stick left and right continuously until all 4 LEDs slowly flash yellow. Calibration is complete when all 4 LED indicators stop flashing. It is recommended that users wait for 15-20 seconds after the calibration is completed before flying again. When using the horizontal calibration, please ensure that the aircraft is on a completely flat surface. Do not move the aircraft or calibrate on an uneven/tilted surface, or there will be errors.

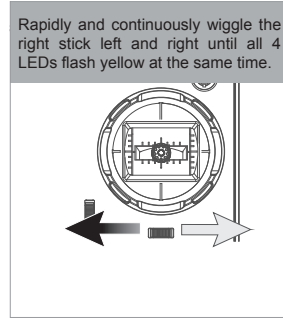
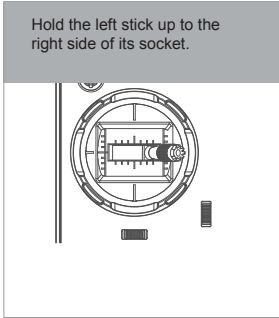

6.3 Rotation calibration

If the aircraft drifts while rotating in flight, perform a rotation calibration. Hold the left stick up to the top of its socket. Rapidly and continuously wiggle the right stick up and down until all 4 LEDs flash slowly. Make sure that the quad is on a completely flat and smooth surface; place a small piece of paper under each foot. When all the 4 LED indicators flash in a clockwise pattern, slowly and smoothly rotate the X4 clockwise until all the LEDs turn green. Keep the copter's feet on the surface and on the pieces of paper. The 4 LED indicators will again flash clockwise; repeat step 2. If the quad requests a third rotation, restart the quad and start from step 1. Take care not to lift or jolt the quad while calibrating it. Calibration is complete when the 4 LED indicators stop flashing.

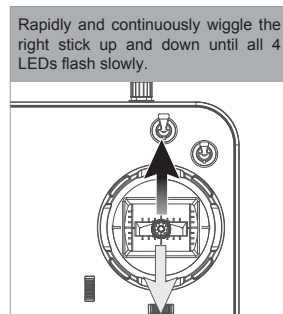
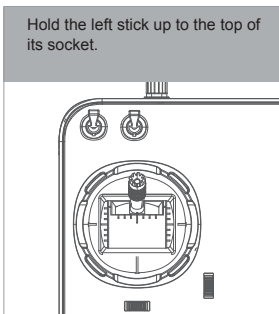

7 Arming/Disarming the Motors

Arming/starting motors

① Simultaneously pull the transmitter joysticks diagonally down-out to arm the motors (as shown in the side figure).

Disarming/stopping motors

① Pull the throttle joystick all the way down until the copter has completed its descent to the ground. Simultaneously pull the transmitter joysticks diagonally down-out to disarm the motors (as shown in the side figure).

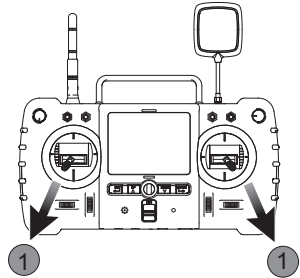

⊘ Do not disarm during flight. The motors will stop in midair, causing the aircraft to fall and other such hazards.

💡 Be sure to operate the joysticks slowly and firmly. When disarming, wait until the motors come to a complete stop before releasing the joysticks.

8 Basic Flight Operation

The remote control is by default set to Mode 2 in factory; this manual will introduce flight operations in Mode 2.

- 📄 -Transmitter joysticks are self-centering and spring loaded: the joysticks will automatically center themselves.
- Joystick sensitivity: dependent how much and how forcefully each joystick is pulled or pushed away from center point.

Remote Control (Mode 2)	Aircraft	Transmitter controls
	<p style="text-align: center;">Ascend</p> <p style="text-align: center;">Descend</p>	<p>The throttle is used to control the ascent and descent of the aircraft. Push the throttle up and the aircraft ascends. Pull the throttle back and the aircraft descends. When the joystick is centered (unmoving), the aircraft will hold its altitude in the air. The throttle must be pushed upwards beyond center point for the aircraft to completely takeoff from the ground. The harder the throttle is pushed, the faster the aircraft will ascend. Please push the throttle slowly for a gradual lift and to prevent the aircraft from ascending erratically.</p>
	<p style="text-align: center;">Clockwise rotation</p> <p style="text-align: center;">Counterclockwise rotation</p>	<p>The rudder is used to control the aircraft's rotations. Push the joystick to the left and the aircraft rotates counterclockwise. Push the joystick to the right and the aircraft rotates clockwise. When the joystick is centered (unmoving), the angular velocity of the aircraft is "0" and the aircraft will not turn. How hard the rudder is pushed will determine the angular velocity of the aircraft's rotation. The harder the rudder is pushed, the faster the aircraft rotates.</p>

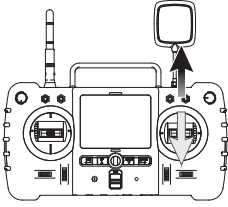
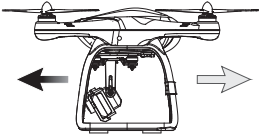
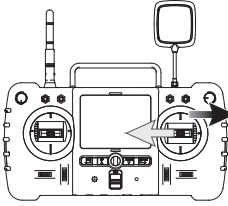
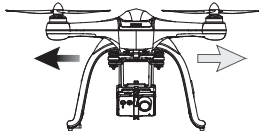
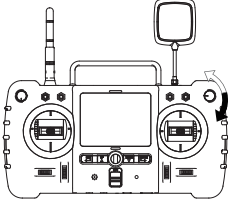
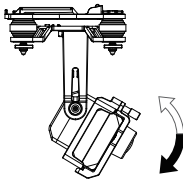
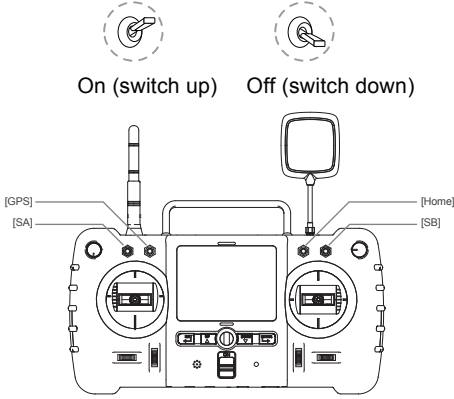
	 <p>Forward Backward</p>	<p>The elevator controls the aircraft's forward and backward movement. Push the joystick forward and the aircraft will tilt and fly forward. Pull the joystick back and the aircraft will tilt and fly backwards. When the joystick is centered (unmoving), the aircraft will hold its altitude in the air. How hard the elevator is pushed will determine the degree of the aircraft's tilt and therefore the velocity of its forward and backward movement. The harder the elevator is pushed, the greater the aircraft's tilt angle and flight speed either forwards or backwards.</p>
	 <p>Right Left</p>	<p>The aileron controls the aircraft's left and right movement. Push the joystick to the left and the aircraft will tilt and fly leftwards. Pull the joystick to the right and the aircraft will tilt and fly rightwards. When the joystick is centered (unmoving), the aircraft will hold its altitude in the air. How hard the aileron is pushed will determine the degree of the aircraft's tilt and therefore the velocity of its left and right movement. The harder the aileron is pushed, the greater the aircraft's tilt angle and flight speed either leftwards or rightwards.</p>
		<p>The T2 knob is used to control the gimbal and camera angle. Turn the knob clockwise and the gimbal will tilt the camera upwards. Turn the knob counterclockwise and the gimbal will tilt the camera downwards.</p>
		<p>GPS switch for GPS Hold mode When the switch is up, GPS Hold mode is on. When the switch is down, GPS Hold mode is off.</p> <p>SA (switch A) for Headless mode When the switch is up, Headless mode is on. When the switch is down, Headless mode is off.</p> <p>Return to Home switch for Return to Home mode When the switch is up, RTH mode is on. When the switch is down, RTH mode is off.</p> <p>SB (switch B) for Follow Me mode When the switch is up, Follow Me mode is on. When the switch is down, Follow Me mode is off.</p>

9 Advanced performance set up

1) Reverse channel setup

If you would like to reverse any of the stick functions, please follow the instructions below. Be aware that this will reverse the control commands.

Pull the throttle stick down to the lowest position and long press the 'Enter' key to open the 'Main Menu' interface. Use the Up/Down keys to select 'Set reverse' and use the 'Enter' key to switch between modes. Long press 'Exit' key to save and exit.

```
12.2V 7.0V
>Set reverse +
Set sensitive +
Manual mode OFF
Expert mode YES
Stick mode 1
5.8G frequency
Fly when no GPS NO
Show Version
```

```
12.2V 7.0V
Set reverse -
>Elevator Normal
Aileron Normal
Throttle Normal
Rudder Normal
Set sensitive +
Manual mode OFF
Expert mode YES
Stick mode 1
5.8G frequency
Fly when no GPS NO
```

2) Sensitivity setup

If you would like to adjust the sensitivity of any stick functions, then follow the instructions below.

Pull the throttle stick down to the lowest position and long press the 'Enter' key to open the 'Main Menu' interface. Use the Up/Down keys to select 'Set sensitive' and use the 'Enter' key to switch between 'Expert mode' and 'Normal Mode'. Long press 'Exit' key to save and exit.

```
12.2V 7.2V
Set reverse +
>Set sensitive +
Manual mode OFF
Expert mode YES
Stick mode 1
5.8G frequency
Fly when no GPS NO
Show Version
```

```
12.2V 7.0V
Set reverse +
Set sensitive -
Elevator 100
Aileron 100
Rudder 100
Manual mode OFF
Expert mode YES
Stick mode 1
5.8G frequency
Fly when no GPS NO
Show Version
```

3) Headless mode

When Headless mode is activated, the aircraft will use whichever direction its head is facing as the default forward position in Headless mode. For example, if the aircraft's head is facing north when you enter Headless mode, you can turn any side of the aircraft due north and still fly forward.

Flip the A switch up to enter Headless mode; flip the A switch down to exit Headless mode. The Head telemetry symbol is red when the aircraft is in Headless mode and green when the aircraft is not.

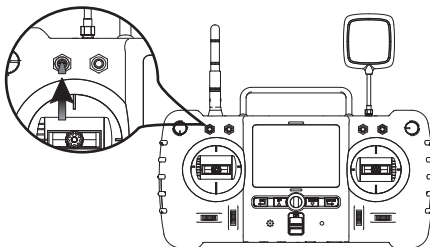

4) Follow Me mode

- ⚠ The transmitter has a built-in GPS module. Follow Me mode functions only when both the aircraft and the transmitter have 6 or more GPS satellites.
-

Flip the B switch up to enter Follow Me mode; flip the B switch down to exit Follow Me mode. When the switch is up, the screen will say "Follow Mode" in green. The aircraft will turn and face the transmitter. Only the throttle will be active at this time.

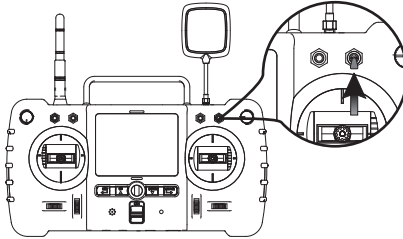

5) Return to Home mode

- ⚠ • Return to Home mode will only work when the aircraft has 6 or more satellites. Never activate Return to home when the GPS switch is down.
-

Entering Return to Home mode

Make sure GPS mode is on (the GPS is up). Then, flip the RTH switch up to activate Return to Home mode. The flight control system will command the aircraft to return to its designated "home" point. Users can either allow the flight system to land the aircraft automatically, or exit Return to Home and land the aircraft manually.

6) Exiting Return to Home mode

- ⚠ • Use this function only if the aircraft has 6 or more GPS satellites.
-

Flip the RTH switch down to exit Return to Home mode. Land the aircraft manually.

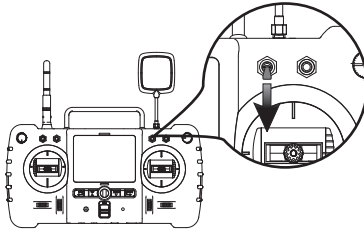

10 The Fail Safes

10.1 Low power failsafe

When the aircraft battery is low, there is likely insufficient power to support the return of the aircraft. Please land the aircraft immediately, otherwise the aircraft will fall and cause damage to the aircraft and surrounding objects. To prevent this, the aircraft flight control will use flight information to determine whether to perform a Return to Home or to land immediately.

10.2 Loss of flight control failsafe

When the flight control connection between the aircraft and transmitter is lost, the aircraft will automatically land or return to where the remote control/transmitter was last located and land there. This can drastically reduce the possibility of the aircraft crashing or being lost.

Return Home point/Takeoff point: When the aircraft and transmitter have gained 6 or more satellites in GPS Hold mode, the failsafe "home" point will be recorded as the takeoff point.

10.3 Conditions that may trigger a failsafe

- 1) Transmitter is powered off.
- 2) The flight distance exceeds the remote control's signal transmission range.
- 3) There is an obstacle between the remote control and aircraft.
- 4) The flight control or transmitter signal is interrupted by strong external electronic interference.

⚠ -To ensure the successful return of the aircraft if it loses flight control connection, users must confirm that the aircraft has enough GPS satellites to fly safely in GPS mode. Users must also be certain that the flight environment is clear enough for an emergency return and landing.

- If the aircraft's GPS satellites drop below 6 for more than 20 seconds while the X4 is returning to Home Point, the aircraft will automatically descend.
- The X4 cannot avoid obstacles automatically while in Failsafe mode. Users may set the Return to Home height to avoid running the aircraft into obstructions.

Frequently Asked Questions (FAQ)

1) Cannot arm motors

Try calibrating the transmitter sticks as shown below. Afterwards, check that all channels are properly moving and centered.

Mode 1: Push the left stick to the upper left corner and the right stick to the upper right corner. Power the transmitter on while holding both sticks in their respective positions; the LCD screen will show "Calibrate Sticks Mode 2". Let go of the sticks, then pull them up, down, towards the center and outwards. Repeat this sequence 3 times, then release both sticks and hold the "Exit" key until the transmitter beeps. This indicates a successful calibration.

Mode 2: Push both sticks to the upper left corners. Power the transmitter on while holding both sticks in their respective positions; the LCD screen will show "Calibrate Sticks Mode 2". Let go of the sticks, then pull them up, down, towards the center and outwards. Repeat this sequence 3 times, then release both sticks and hold the "Exit" key until the transmitter beeps. This indicates a successful calibration.

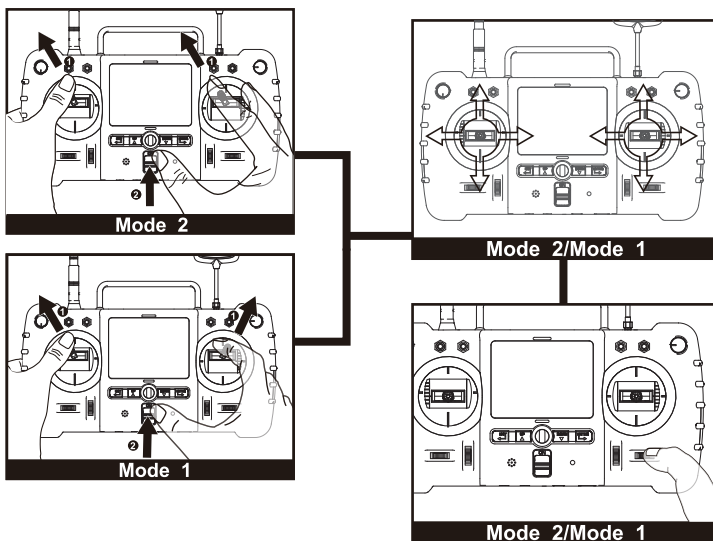

2) Changing from Mode 1 to Mode 2

(1) Use the above transmitter stick calibration to switch and set the throttle for Mode 1 or Mode 2.

(2) After completing the corresponding calibration, confirm that the throttle has been properly set by turning the transmitter on.

- 3) Uneven takeoff/unstable takeoff or flight
 - (1) Please keep the aircraft on a completely flat and stable surface after connecting it to power. Allow it to sit still for at least 10 seconds before taking off (as to allow the gyro sensor to properly initialize).
 - (2) Place the aircraft on a completely flat and stable surface. Observe to see if the Roll (R) and Pitch (P) telemetry values on the transmitter screen are 0. If they are not, please perform a horizontal/gyro calibration for the aircraft.
- 4) The aircraft drifts badly in GPS Hold mode
 - (1) Check the surrounding area to see if there are any sources of GPS interference.
 - (2) Manually calibrate the compass.
- 5) The transmitter beeps

Check the transmitter's power levels; please pause the flight to change and charge batteries.
- 6) When connected to power, the aircraft beeps incessantly

The flight control firmware needs to be reflashed appropriately.
- 7) There is no FPV
 - (1) Verify that the camera is powered on, the camera battery is sufficiently charged and that the camera is properly connected to the aircraft.
 - (2) Rebind the aircraft to its transmitter.
- 8) The gimbal does not move or react

Make sure that the gimbal line is properly connected to the aircraft, especially after a crash. Always check the state of the aircraft and its components after any kind of crash.

Technical assistance

If you need assistance setting up or using your Aerpro product now or in the future, call or email Aerpro Support (Australia and International inquiries).

NOTE: Maintaining control of the drone while flying is the sole responsibility of the pilot. Any loss or damage caused while flying is NOT covered by warranty.

Email: service@tdj.com.au
 TEL: +61 3 8587 8898
 FAX: +61 3 8587 8866
 Mon-Fri 9am – 5pm AEST
 Please retain this user guide for future reference.

If you would like to download a digital copy of this manual, or other Aerpro manuals/software, please visit the <http://aerprodrone.com> website.
 This manual is considered correct at time of printing but is subject to change. For latest manuals and updates refer to the website.

Copyright © 2017 by TDJ Australia
 All rights reserved. No part of this publication may be reproduced, distributed, or transmitted in any form or by any means, including photocopying, recording, copying or other electronic or mechanical methods, without the prior written permission of the author.

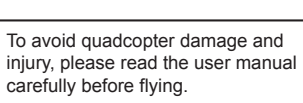

Features & Specifications



2.4GHz RC series
5.8Ghz FPV system



GPS Positioning
GPS-RTH
Auto-pilot function
GPS and altitude modes provide stability



Automatic return switch
Failsafe to return home & landing



Compass sensor



Flight time around 20-25 minutes
11.1V 7000mAH Li-Po battery
Low voltage battery protection



1080P High Definition camera
Can carry all smartphones
Photo/Video
Stable 1 Axis Gimbal System
FPV1 Transmitter



Charging Time- 150 minutes
Distance- 1000 meters

Size- 11.8*11.8in

Laws & Regulations on flying your drone (AUS)



You need to be able to see the aircraft, with your own eyes (eg, without binoculars) at all times.

Don't let it get too far away from you!



You need to fly the aircraft so it isn't a hazard to other aircraft, property, and people.

That means not flying it over areas where there are people.



Fly the aircraft in daylight only.



Give way to all other aircraft.

You don't want your aircraft destroyed in a collision with a bigger aircraft, or be responsible for damaging it, or for putting people's lives at risk.

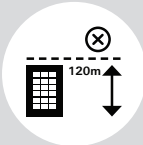

You cannot fly your aircraft higher than 120 metres (400 feet) above ground level.



You cannot fly closer than 5.5 kilometres from an airfield.

You cannot fly in controlled airspace without a clearance from Air Traffic Control. For more information, see the CASA web site.

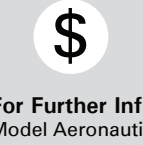

It's illegal to fly for money or economic reward unless you have correct certification from (CASA)

For Further Information:

Model Aeronautical Association of Australia www.maaa.asn.au

or

CASA casa.gov.au/rpa casa.gov.au/sportaviation

Phone 131 757

Laws & Regulations on flying your drone (NZ)



You need to be able to see the aircraft, with your own eyes (eg, without binoculars) at all times.

Don't let it get too far away from you!



You need to fly the aircraft so it isn't a hazard to other aircraft, property, and people.

That means not flying it over areas where there are people.



Fly the aircraft in daylight only.



Give way to all other aircraft.

You don't want your aircraft destroyed in a collision with a bigger aircraft, or be responsible for damaging it, or for putting people's lives at risk.



You cannot fly your aircraft higher than 120 metres (400 feet) above ground level.



You cannot fly closer than four kilometres from any aerodrome.

You cannot fly in controlled airspace without a clearance from Air Traffic Control. For more information, see the CAA web site.

You can fly outside some of these conditions, but there are more rules to keep you and your aircraft safe, so contact Model Flying New Zealand or the Civil Aviation Authority.

www.nzmaa.org.nz

www.caa.govt.nz/rpas